

# Maseno University Journal

VOLUME 1

JANUARY 2015

*Proceedings of the Multidisciplinary Conference Held at Maseno University on 30 June-1 July  
2014*

---

**Editorial Board**

---

***Editor in Chief:***

Professor Collins Ouma, Department of Biomedical Sciences,  
Maseno University, P.O. Box 333 Maseno, Code 40105, Kenya.  
Email: [couma@maseno.ac.ke](mailto:couma@maseno.ac.ke)

***Sub-Editors in Chief:***

Professor Francis Indoshi, Department of Curriculum and Communication Technology,  
Maseno University, P. O. Box, Private Bag, Code 40105, Maseno, Kenya.  
Email: [findoshi@yahoo.com](mailto:findoshi@yahoo.com)

Dr. Samwel B. Anyona, Department of Medical Biochemistry, School of Medicine,  
Maseno University, P. O. Box, Private Bag, Code 40105, Maseno, Kenya.  
E-mail: [sanyona@maseno.ac.ke](mailto:sanyona@maseno.ac.ke)

Dr. Wilson Okumu, Department of Medical Biochemistry, School of Medicine,  
Maseno University, P. O. Box, Private Bag, Code 40105, Maseno, Kenya.  
E-mail: [wookumu@maseno.ac.ke](mailto:wookumu@maseno.ac.ke)

---

***SERIES A: (Humanities and Social Sciences)      Editors***

Prof. Fredrick Wanyama, School of Development and Strategic Studies,  
Maseno University, Private Bag, Maseno.  
Email: [fwanyama@maseno.ac.ke](mailto:fwanyama@maseno.ac.ke)

Prof. George Mark Onyango, School of Environment and Earth Sciences,  
Maseno University, Private Bag, Maseno.  
Email: [georgemarkonyango@maseno.ac.ke](mailto:georgemarkonyango@maseno.ac.ke)

Dr. Susan M. Kilonzo, Department of Religion and Philosophy,  
Maseno University, Private Bag, Maseno.  
Email: [mbusupa@yahoo.com](mailto:mbusupa@yahoo.com)

Dr. Leah Onyango, School of Environment and Earth Sciences,  
Maseno University, Private Bag, Maseno.  
Email: [lonyango@maseno.ac.ke](mailto:lonyango@maseno.ac.ke)

---

***International Advisory Editorial Board***

Prof. Ezra Chitando, Department of Religious Studies,  
University of Zimbabwe, W.C.C. Consultant on the Ecumenical HIV/AIDS  
Initiative in Africa.  
Email [Chitsa21@yahoo.com](mailto:Chitsa21@yahoo.com)

Prof. Dismas A. Masolo, Humanities, Department of Philosophy,  
University of Louisville, Louisville, Kentucky.  
Email [Da.masolo@louisville.edu](mailto:Da.masolo@louisville.edu)

Dr. Sandya Gihar, Advanced Institute of Management,  
(Chaudhary Chara Singh University, Meerit), NH-35, Delhi-Hapur Bye Pass  
Road, Ghaziabad, India.  
Email: [drsandhya05@gmail.com](mailto:drsandhya05@gmail.com)

Prof. Shem O. Wandiga, Department of Chemistry,  
University of Nairobi, P.O. Box 30197 - 00100 GPO, Nairobi, Kenya.  
Email: [sowandiga@iconnect.co.ke](mailto:sowandiga@iconnect.co.ke)

Prof. Tim May, Co-Director, Centre for Sustainable Urban and Regional Futures (SURF),  
University of Salford, Manchester, U.K.  
Email: [T.May@salford.ac.uk](mailto:T.May@salford.ac.uk)

---

**MASENO UNIVERSITY JOURNAL**

*Copyright ©2015*

*Maseno University*  
Private Bag, Maseno 40105  
Kenya

Maseno University Journal is an academic channel for dissemination of scientific, social and technological knowledge internationally. To achieve this objective, the journal publishes original research and/or review articles both in the Humanities & Social Sciences, and Natural & Applied Sciences. Such articles should engage current debates in the respective disciplines and clearly show a contribution to the existing knowledge.

The submitted articles will be subjected to rigorous peer-review and decisions on their publication will be made by the editors of the journal, following reviewers' advice. Maseno University does not necessarily agree with, nor take responsibility for information contained in articles submitted by the contributors.

The journal shall not be reproduced in part or whole without the permission of the Vice Chancellor, Maseno University.

Notes and guides to authors can be obtained from the Maseno University website or at the back of this issue of the journal every year, but authors are encouraged to read recent issues of the journal.

**ISSN 2075-7654**

## Table of Content

<b>Editorial Board.....</b>	<b>i</b>
<b>Table of Content.....</b>	<b>iv</b>
 <b>ARTICLES</b>	
<b>From Markets to Small Towns: The Challenges of Rapid Urbanization and Land Use Change within the Mara River Basin, Kenya .....</b>	<b>1</b>
Abuya J. <sup>1*</sup> , Onyango, G.O. <sup>1</sup> .....	1
<b>Loosing Species, Loosing Language: Connecting Language and the Environment.....</b>	<b>7</b>
Beatrice A. Okoth <sup>1</sup> and Judith Miguda- Attyang <sup>2*</sup> .....	7
<b>Telemedicine: A Digital Public Health Option for Counties and Their Perceived Concerns in Enhancing Healthcare .....</b>	<b>15</b>
Asava Tim Kiziiri <sup>1*</sup> .....	15
<b>Peace Through Devolution for Sustainable Development: The Kenyan Case .....</b>	<b>20</b>
Ambuyo Beverlyne Asiko <sup>1*</sup> .....	20
<b>Knowledge Economy as a Way of Securing Peace and Sustainable Development in the 21<sup>st</sup> Century .....</b>	<b>31</b>
Constance Ayabei <sup>1*</sup> and Dickson S. O. Owiti <sup>2</sup> .....	31
<b>Village Elites and Community Development in Kenya .....</b>	<b>39</b>
George M. Onyango <sup>1*</sup> and Lillian A. Omondi <sup>2</sup> .....	39
<b>Flood Management Capacity in the Lake Victoria Basin, Kenya: A Case Study of the Migori-Gucha River Basin .....</b>	<b>57</b>
Abuya, J <sup>1</sup> .....	57
<b>Fallacious Sexuality Knowledge and Its Implications among the Akamba Adolescents in Machakos County, Kenya .....</b>	<b>68</b>
Felix N. Kioli <sup>1*</sup> , Peter G. Oino <sup>1</sup> and Sussy Gumo <sup>2</sup> .....	68
<b>Chimbuko la ‘Sheng’ na Athari Zake kwa Lugha ya Kiswahili: Mpangilio wa Kifani, Chuo Kikuu cha Maseno.....</b>	<b>82</b>
Mary Lukamika <sup>1*</sup> .....	82
<b>The Question of Elitism, Medium and Audience in African Literature: Examples from Kiswahili Short Story.....</b>	<b>88</b>
MConyango Owen Ouko <sup>1*</sup> .....	88

<b>Challenges of Reconciliation and Conflict Resolution for the Christian Churches in Eastern Africa: Roman Catholic Church Perspective .....</b>	<b>96</b>
Ambrose O. Mbuya <sup>1*</sup> and Sussy Gumo <sup>1</sup> .....	96
<b>Linguistic Effects of Globalization: A Case Study of French for Specific Purposes (FSP) in Kenya .....</b>	<b>112</b>
Mubalama Mulenda <sup>1*</sup> , Muteba Kazadi <sup>2</sup> , Ndiabou Touré Segá <sup>3</sup> , Clara Bulili <sup>1</sup> .....	112
<b>Evaluation of Textual Competence of Kenyan Students Learning French as a Foreign Language .....</b>	<b>122</b>
Ngoy Mwilambwe <sup>1*</sup> , N'diabou Segá Touré <sup>2</sup> , Muteba Kazadi <sup>3</sup> .....	122
<b>Chamas as Informal Social Protection among Street Vendors and Market Sellers in Kisumu City, Kenya: Perceptions of Poverty, Vulnerability and Exclusion.....</b>	<b>136</b>
Karen N. Nyangara <sup>1*</sup> .....	136
<b>Analysis of the Disaster Management Policy and the Challenges Faced by the County Government Authorities in Disaster Awareness and Management in Kenya .....</b>	<b>141</b>
Jasper E. Nyaura <sup>1*</sup> and Margaret N. Ngugi <sup>1</sup> .....	141
<b>Role of <i>Bodaboda</i> (Motorcycle and Bicycle) in Urban Transportation System in Kenya .</b>	<b>152</b>
Jasper E. Nyaura <sup>1*</sup> and Margaret N. Ngugi <sup>1</sup> .....	152
<b>Expected Role of Information Systems on County Revenue Collection by Homa Bay County Government, Kenya .....</b>	<b>158</b>
Odoyo Collins Otieno <sup>1*</sup> .....	158
<b>Socio-Economic Factors Influencing Smallholder Maize Production in Migori County, Kenya .....</b>	<b>167</b>
Ojala, D. O. <sup>1*</sup> , Nyangweso, P. M. <sup>1</sup> , Mudaki, J. S. <sup>1</sup> , Zablon E. <sup>1</sup> , Korir M. <sup>1</sup> and Kiano, E. K. <sup>1</sup> .....	167
<b>Analysis of the Obama Victory Speech and Lessons to Makers of Political Diatribe.....</b>	<b>176</b>
Benard Odoyo Okal <sup>1*</sup> .....	176
<b>Factors Influencing Sexual Practices of Widows Living with HIV and AIDS in Kondele Location, Kisumu Municipality .....</b>	<b>192</b>
Okuto-Agache, J <sup>1*</sup> , Kioli, N. Felix <sup>1</sup> and Nyambedha E.O. <sup>1</sup> .....	192
<b>Ethnolinguistic Impact of Social Network in Kinubi Vitality .....</b>	<b>208</b>
Yakub Adams <sup>1*</sup> , Peter M. Matu <sup>2</sup> , David O. Ongarora <sup>3</sup> .....	208
<b>Analysis of Consumer Preferences for Indigenous Chicken in Kisumu City, Kenya .....</b>	<b>217</b>
Fredrick Onyango Aila <sup>1*</sup> .....	217
<b>Promoting Knowledge-based Economy for Sustainable Development for the 21<sup>st</sup> Century: an STS Perspective .....</b>	<b>234</b>
Arun Datta <sup>1</sup> .....	234

<b>Reviewing the Case of Sustainable Management of Water Hyacinth in Lake Victoria, Kenya .....</b>	<b>238</b>
C. M. Mutebi <sup>*1</sup> , G. O. Opande <sup>2</sup> , P. F. Arama <sup>3</sup> and D. Buyela <sup>2</sup> .....	238
<b>Towards Macroeconomic Convergence and Monetary Coordination: Challenges to Regional Integration in Sub-Saharan Africa.....</b>	<b>245</b>
Okech, S. O. <sup>*1</sup> , Ngigi, M. <sup>2</sup> , Basweti, E. <sup>3</sup> , Kibet, N. <sup>1</sup> and Okeyo, B. O. <sup>4</sup> .....	245
<b>Towards Clean Information and Communication Technology Campaign in Public Universities in Kenya .....</b>	<b>262</b>
Obare E. Oteyo <sup>1*</sup> , Okoyo H. Okora <sup>2</sup> , Oginda Moses <sup>3</sup> and Ratemo C. Makiya <sup>1</sup> .....	262
<b>Sustainable Use of Business Intelligence Tools at Kisii Bottlers (K) Limited .....</b>	<b>272</b>
Ratemo Cyprian Makiya <sup>1*</sup> ; Obare Erick Oteyo <sup>1</sup> .....	272
<b>Bandwidth Enhancement of a Circular Microstrip Patch Antenna through Shape Modification in the S-Band.....</b>	<b>282</b>
<sup>1</sup> Kipkorir Langat, B. K. <sup>*</sup> , <sup>1</sup> Langat, K. P., <sup>1</sup> Musyoki, S. ....	282
<b>Assessment of Infant Feeding Practices Among Mothers in Urunga Division, Siaya County, Kenya .....</b>	<b>297</b>
Kipyegon, C. A. <sup>1*</sup> .....	297
<b>On a Complex Spacetime Frame: New Foundation for Physics and Mathematics.....</b>	<b>305</b>
Joseph Akeyo Omolo <sup>1*</sup> .....	305
<b>Guide for Authors .....</b>	<b>330</b>
Submission of Papers .....	330
Manuscript Preparation.....	332

***HUMANITIES AND SOCIAL  
SCIENCES***



# From Markets to Small Towns: The Challenges of Rapid Urbanization and Land Use Change within the Mara River Basin, Kenya

By

Abuya J.<sup>1\*</sup>, Onyango, G.O.<sup>1</sup>

<sup>1</sup>*School of Planning and Architecture, Maseno University, Kenya,*

*\*Corresponding author: [jabuya2000@yahoo.com](mailto:jabuya2000@yahoo.com)*

---

## Abstract

Current statistics show that urban growth rates are relatively higher in the Small and Intermediate urban centres in Kenya. This study sought to analyze the impacts of urbanization driven land use changes within the Mara river basin. Selected towns (Silibwet, Bomet, Longisa, Singiroi and Sigor) falling in the Small and Intermediate urban centres category were used in the analysis. The study used both primary and secondary sources of information collected through structured questionnaires administered to over 400 households, Key informant interviews, transect survey and observations. The findings indicate that the urban population growth rates within the basin are almost twice as much as the average national urban population growth rates. Most towns lack adequate institutional capacity to plan their physical/spatial growth thus leading to urban sprawl manifested by increased land cover changes dominated by the urban built environment. A better understanding of the spatial and temporal dynamics of the urban centers growth, provided by this study, forms a basis for better planning and effective spatial organization of urban activities for future growth and development of towns within the Mara River Basin with possibility of replicating best practices in other towns.

**Key words:** Urbanization, Water resources, Land use-land cover change, Small and Intermediate Urban centres.

---

## Introduction

The world today is experiencing rapid urbanization that is increasingly concentrating both population and economic activities in cities. This is because cities have become remarkable engines of economic growth and social progress. Sub Saharan Africa (SSA) however, is witnessing one of the unprecedented high urban growth rates, often exceeding 5 per cent per annum, twice as high as Latin America and Asia (UN Habitat, 2005). This high rate of

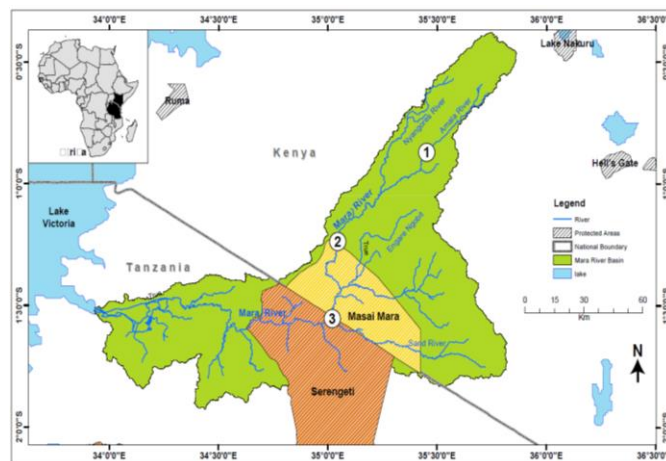
urbanization in SSA has however not been accompanied by a similar rate of economic development. As a consequence, cities in SSA have had to face typical negative externalities connected with urbanization such as high poverty rates, social inequalities, urban sprawl and congestion, environmental problems, housing shortages, slum formation and growth, violence and crime and distressed areas.

The urbanization trends in SSA's are reflected in Kenya too. According to the World Bank, (2011b) Kenya's population is growing fast, increasingly so in urban areas. Every year more than 250,000 Kenyans are moving to urban areas and formerly rural areas are becoming increasingly urban. Twenty years ago Kenya's urbanization level was only 18% (World Bank, 2011a). Since then, Kenya's urban population has been rising rapidly. The share of the urban population is set to rise to 37% by 2020, and in 2033 Kenya will reach an important milestone, when most of its population will live in urban areas (World Bank, 2011a).

Noteworthy, however, is that this demographic transition has also coincided with spatial transformations. This is because urban environments represent one of the most rapid and longest-lasting forms of land use/cover transformation (Douglas 1994; Sánchez-Rodríguez *et al.*, 2005). Though urban land cover comprises a small percentage of the global land surface, urban interests increasingly drive rural land-cover change because urban populations and economic activities require resources that extend far beyond the boundaries of the urban environment (Lambin *et al.*, 2003). Another consequence of urbanization is the concentration of human populations in space, leading to significant transformation of land, water, material, and energy resources. Urban areas can thus be considered environmental problems in their own right (Grimm *et al.*, 2008; Perz, 2000). To fully account for human impacts on the environment therefore, urban landscapes and processes thereon should be considered for investigation (Powel and Roberts, 2010). The Kenya government also acknowledges that, 'rapid urbanization has infringed on environmentally sensitive areas such as wetlands, hilltops, water bodies and the coastline' (GoK, 2009b).

According to UN-Habitat (2008), in the foreseeable future, the intermediate cities (towns with less than 500,000 inhabitants) will be the localities where two-thirds of all

African urban growth will be occurring. In Kenya currently, 65% of all urban dwellers live in towns with less than 500,000 people and 37% of all urban dwellers live in towns with less than 100,000 people (Small towns) (GoK, 2009; Census, 2009). These towns are likely to face greater hardships in planning for their land uses and other services for their residents.



**Figure 1: The Mara River Basin** (source LVBC, WWF-ESARPO, 2010)

Due to the municipalities' inadequate capacities in managing the rapid growth; planning, land allocation, physical and social infrastructures are all deplorably inadequate to cope with the burgeoning population. As a result, an increasing part of the urban population lives in unplanned, often illegal, shanty-towns with limited access to basic needs and with environmental conditions that threaten life and health (Tannerfeldt, 2002). The resultant haphazard spatial growth of the urban centres strays on public spaces, urban fringes and distressed areas of the city consequently encroaching on fragile ecosystems, riparian areas, slopes, water courses etc. This has had an effect on land and water resources. In effect exacerbating water stress in terms of its supply, accessibility, quality and quantity.

It is in view of the foregoing that the Mara River basin has been chosen for this study. The Mara river basin has witnessed a dramatic growth in human population especially within its urban areas in the last

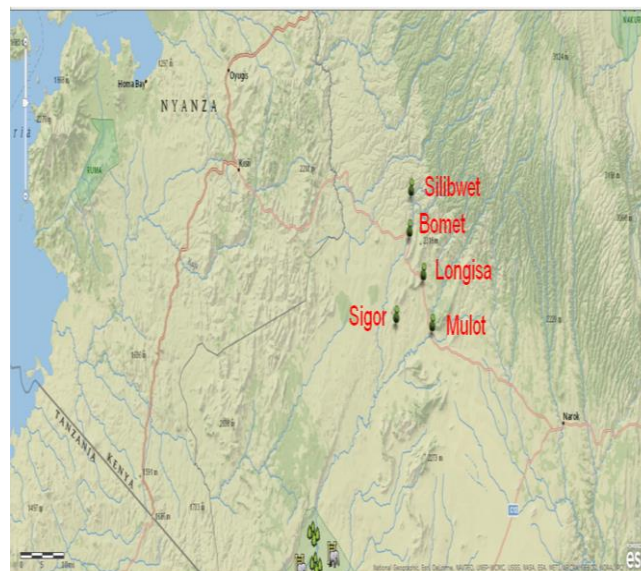
few decades. The population on the Kenyan side of the Mara River Basin is growing at an annual rate of more than 3%. The BSAP (2010) provides an estimate of 660,320 people in 2000 rising to 838,701 in 2010 and over 1,350,000 in 2030 based on work by Hoffman (2007) (LVBC, 2012). This rise in population, with the accompanying associated economic activities, has heralded the growth of small urban centres in the region. These are towns which barely 30 years ago started as small market centres, variously positioned for flows of resources, goods and people.

The overall objective of this study therefore, was to investigate the character and trend of land use changes brought about by urbanization processes within the Mara river basin in Kenya.

### The Study area

The Mara River Basin forms one of 10 major rivers that drain into Lake Victoria. It is a trans-boundary watercourse with 65% of its catchment in Kenya and the other 35% in Tanzania. The total area of the Basin is about 13,834 km<sup>2</sup> (Mutie, 2006). Tributaries of the Mara originate in the Enapuiyapui swamp at a height of 2,932 metres asl and elsewhere on the Mau Escarpment. From its main source the river descends over 1,000 metres in a distance of around 200 kilometers before it reaches the Old Mara Bridge at the start of the Masai Mara plains. The river then flows in a series of meanders through the plains of Maasai Mara National Game Reserve in Kenya and Serengeti National Park in Tanzania before entering Lake Victoria at an altitude of 1,134 (LVBC, 2012).

This study made an assessment on selected key urban centres within the basin. They are Bomet, Mulot, Longisa, Sigor and Silibwet. It therefore delineated a trapezoid area encompassing the towns as shown in Figure 2.



**Figure 2: The Study Site**

### Methodology

This study has used both primary and secondary sources of information, Household interviews, Key informant interviews, transect survey and observations in collection of data. A checklist of questions and discussion points were administered to the Bomet District Public Health Officer, Bomet District Physical Planner, Bomet Municipal Council Officers. Unstructured interviews were also administered to 20 residents of 'Kambi Shetani' informal settlement within Bomet town. Obtained information was logically collated and corroborated to inform preliminary findings. The study envisages a consequent more scientific and comprehensive data collection and analysis process.

### Results and Discussions

A comparison of population statistics based on the government of Kenya Census Reports and Bomet District Development Plan; Bomet, Singiroi, Longisa, Sigor Towns within the basin, have registered a cumulative population growth rate of 22% (from 114,703 to 147,397 people) in the last 10 years (GoK, 2009), higher than the national urban growth rate of 13% (from 9,996,991 to 11,545,000 people) in the same

period. This is indicative of the relatively rapid rise of urban population within the basin.

This urban population growth rate has been accompanied by increased land use land cover transformations in the basin. For example, Agricultural land has expanded from 8\26 to 2,504 ha. (an increase of 203%). Tea plantations and open forest cultivation has grown from 621 hectares to 1948 ha (+214%) and areas of wetland in the lower valley have grown from 286 ha to 1,394 ha, largely as a result of flooding caused by siltation (an increase of 387%). In addition to the associated effects of deforestation, water abstractions for livestock, agricultural irrigation and other industries have been also on the rise (LVBC, WWF-ESARPO, 2010). The urbanization processes can therefore be seen to have had a partial role in the challenges of land use and water resource management in the basin. With the changes in the patterns and sizes of human settlements, water demand is also likely to increase, caused either by the primary or secondary effects of natural change, or because of the local governments' planning policies that shapes the pattern or density of future land uses.

According to the Bomet District Physical Planner, the district, within the last five years, has registered the highest number of construction activities in its history. This is partly due to the need to provide housing to the increasing population but also to provide commercial and industrial facilities to service the booming agricultural and tourism sectors. There has also been a remarked development in construction of infrastructure, for example, roads. This means that there has been a significant land cover change from shrubland and or agricultural land into impervious surfaces. The amount of urban services has also more than doubled within the last five years.

Table 1 shows the current number of the said services and facilities as per the District Public Health Officers records (2012) demonstrating an upswing of about 50%.

**Table 1. Services and facilities**

SERVICE/PREMISES		Quantity
1	Retail shops & Kiosks	784
2	Wholesalers	33
3	Butcheries	178
4	Restaurants/ Eating Houses/Rooms	304
5	Bars	92
6	Wine and Spirits shops	36
7	Posho mills	126
8	Supermarkets	6
10	Agro vets	36
11	Chemists	32
12	Soda depots	6
14	Milk Bars	5
15	Private clinics	22
17	Slaughter slabs	23
18	Slaughter housess	2
19	Beer depots	5
20	Bakeries	7
21	Food warehouses	4
22	Hotels	1
23	Lodgings	44
24	Food Factories	3
26	Food handling establishments	1,318

As enumerated above, the Mara river basin has experienced both rapid urbanization and high land use land cover changes in the recent past. However, limited studies have been conducted to investigate the character of land use land cover changes in the past and how they affect water resources. The most elaborate study was by Mutie *et al.*, (2006), which sought to investigate the Land use effects on the River Mara stream flow using the USGS geospatial stream flow model. The study used eight land use land cover classifications, namely; Forests, Tea/ Open forest, Agricultural land, Shrub land,

Grass land, Savannah, Wetlands, Water body. Few other studies done have used lesser number of classification parameters and none has used 'urbanization' as a parameter. It is on that basis that this study sought to use the additional parameter; 'urbanization', whereby land use changes brought about by urbanization processes is investigated and analysis made on the spatial implications that such has had on water resources. In that case therefore, the following questions were considered important; is there a link between urbanization and land use/cover change? are there spatial impacts of urbanization induced land use/cover change on the water resources within the Mara river basin? Such inquiry could contribute to longitudinal studies of urban areas and provide a first step in linking urbanization to regional land use and land cover change and their effects on water resources.

The study is premised on the fact that water resources are based on land (water catchment areas, wetlands, river courses, underground water, etc). However, increasing urban human settlements, infrastructure development, commercial activities and industrialization arising from urbanization affect total land needs (land required for urbanization-LRU). Also, the intensification of use of land and changes in land cover due to urban pressure leads to certain negative impacts on natural resources like water resources e.g. by encroachment on water catchment areas like forests, springs, blockage or diversion of water courses, deliberate tampering with water flows, over extraction, underground and surface water pollution, increased drought or flooding etc. This study therefore sought to characterize the spatial impacts of urbanization on land and water resources and hence provide a basis for sound planning and management of the processes and resources.

The Kenya Government acknowledges that, 'the use of land in urban and rural areas as well as in the land/water interface has been a major area of concern to all Kenyans.

Problems of rapid urbanization, inadequate land use planning; unsustainable production, poor environmental management, inappropriate ecosystem protection and management are commonplace and require appropriate policy responses (GoK, 2007). This study sought to provide insight to this problem.

In the case of Mara river basin, it was noted that massive and rapid land cover transformations have occurred in the last few decades. This has led to conversions of forest and shrubland into impervious surfaces representative of urban developments. All the urban centres in the study area also do not have trunk sewers hence waste disposal is done on site where they are generated. These have a profound effect on water resources in terms of catchment management and pollution challenges.

Statistics presented on population growth and land conversion show that, within only a few decades at current rates, the unique ecosystem of the Masai Mara/Serengeti will have been largely destroyed, resulting in the loss of one of the main drivers of the economy, increased hardship for more than half a million people through sub-division of land holdings and reduction in soil fertility, and probable conflicts between groups practicing different livelihoods.

### **Conclusions**

The challenge, therefore, for urban planners and policy makers will be to make the most out of the urbanization process by managing the growth of towns to leverage the economic and social dividends while forestalling the negative environmental ramifications and unsustainable natural resource utilization, more so, of land and water resources. This could be achieved through a comprehensive, integrated and participatory planning.

### **References**

**Douglas, I.** (1994). Human Settlements. In *Changes in Land Use and Land Cover: A Global Perspective*, B. L. Turner, II and W.

- B. Meyer (eds.), pp.149-169. Cambridge: Cambridge University Press.
- Government of Kenya.** ( 2007). *National Land Policy*, Government Printers, Nairobi, Kenya.
- Grimm, N. B., Faeth, S. H., Golubiewski, N. E., Redman, C. L., Wu, J., Bai, X., and Briggs, J. M.** (2008). *Global Change and the Ecology of Cities*. *Science*, 319: 756-760.
- Hoffman, C. M.** (2007). *Geospatial mapping and analysis of water availability-demand-use within the Mara River Basin*. MSc Thesis. Florida International University, Miami.
- Lambin E. F., Geist, H. J., and Lepers, E.** (2003). *Dynamics of Land-Use and Land-Cover Change in Tropical Regions*, in *Annual Review of Environment Resource*, July 2003, Louvain.
- LVBC.** (2012). *The Trans-boundary Mara River Basin Strategic Environmental Assessment (MRB SEA)*, LVBC, Kenya.
- LVBC and WWF-ESARPO.** (2010). *Assessing Reserve Flows for the Mara River*. Nairobi and Kisumu, Kenya.
- Lake Victoria Basin Commission and WWF-ESARPO.** (February 2010). *"Biodiversity Strategy and Action Plan for Sustainable Management of the Mara River Basin"*.
- Mutie S. M., Mati, B., Home, P., Gadain, H., and Gathenya, J.** (2006). *Evaluating Land Use Change Effects on river flow Using USGS Geo Spatial Stream Flow model in Mara River Basin, Kenya*, Center for Remote Sensing of Land Surfaces, Bonn.
- Perz, S. G.** (2000). *The Quality of Urban Environments in the Brazilian Amazon*. *Social Indicators Research* 49: 181-212.
- Powel, R. L. and Roberts, D. A.** (2010). *Characterizing Urban Land-Cover Change in Rondônia, Brazil: 1985 to 2000*. *Journal of Latin American Geography* no 9 (3): 183-211.
- Sánchez-Rodriguez, R., Seto, K. C., Simon, D., Solecki, W. D., Kraas, F., and Laumann, G.** (2005). *Science Plan: Urbanization and Global Environmental Change*. Bonn, Germany: International Human Dimensions Programme on Global Environmental Change.
- Tannerfeldt, G. and Ljung, P.** (2002), *More Urban Less Poor*, Earthscan, London.
- UN Habitat.** (2005). *Urbanization Challenges in Sub Saharan Africa*, UN Habitat, Nairobi
- UN Habitat.** (2008a). *Intermediate Cities*, UN Habitat, Nairobi.
- UN Habitat.** (2008b). *State of the World's Cities 2010/2011 Bridging The Urban Divide*, Earthscan, London.
- World Bank.** (2011a). *Making the Most of Kenya's Demographic Change and Rapid Urbanization*, Edition no. 4, World Bank, Nairobi
- World Bank.** (2011b). *Turning the Tide in Turbulent Times ; Making the most of Kenyas Demographic Change and Rapid Urbanization*, in *Kenya Economic Update*, Edition No. 4.

# Loosing Species, Loosing Language: Connecting Language and the Environment

By

Beatrice A. Okoth<sup>1</sup> and Judith Miguda- Attyang<sup>2\*</sup>

<sup>1</sup>*Department of Linguistics, Maseno University, P.O. Box 333, Maseno*

<sup>2</sup>*School of Education and Social Sciences, Jaramogi Oginga Odinga University of Science and Technology, Bondo*

\*Corresponding author [beatyakoth@yahoo.com](mailto:beatyakoth@yahoo.com) and [migudaattyang@yahoo.com](mailto:migudaattyang@yahoo.com)\*

---

## Abstract

This paper explores the relationship between language and the environment. It asserts that as the environment changes, culture and language typically responds by loosing certain terminologies even as it creates new ones to describe the new phenomenon. Languages are used by humans to conceptualize their world: to communicate processes, phenomena, to name places; fauna and flora. Language also expresses a people's attitudes, knowledge, beliefs and practices. To this extent, any significant change in the environment will be reflected in language use. One such cause has been global warming which has resulted in diverse negative ecological changes such as loss of both flora and fauna species, and subsequently loss of indigenous knowledge. This paper, therefore, while drawing examples from dholuo language of a community that lives in the Lake Victoria basin, which has experienced perceived effects of climate change, and from documented literature from the rest of the world will attempt to demonstrate the link between the loss of species and the loss of language.

**Key words:** Species, language, environment, communication

---

## Introduction

Whenever there are discussions on climate change and biodiversity conservations, scientists in board rooms, often bemoan uncontrolled harvesting of trees, poor agricultural practices, uncontrolled emissions of toxic gases into the atmosphere etc., all indicative of mans' insatiable greed and selfish utilizations of these natural resources. Scientists lay bare the worrisome consequences of these-which is not just global warming and its trappings, but a projected extinction of mankind. They then formulate complex solutions. Results of which have been so little. However, there is

one natural resource that is often unmentioned: language.

Language, a tool for communication, an agent of cultural identity and reflector of human personality is under siege, more so the indigenous or local languages. Evidently, indigenous people and local communities, who represent most of the world's cultural diversity, are now forced by rapid economic and political globalization to shift to languages and cultures that are believed to propel them to mainstream society, such as English. Indeed, it is a rapid move towards not just cultural but linguistic

homogenization. In Kenya, there are about 69 distinct ([www.ethnologue.org](http://www.ethnologue.org)) languages spoken. However, the numbers of speakers of these languages are diminishing by the day as people are shifting to Kiswahili and English, the national and official languages respectively. Globally, Grimes (1996) classify over 420 languages out of the 6,703 (or almost 6.3%) in the nearly extinct category. This is a dangerous scenario. First, because communities through their way of speaking, oral traditions and verbal art forms are known to develop and maintain detailed knowledge of ecological niche, a detailed way of extracting, and a detailed way of managing natural resources. Secondly, the convergence towards majority cultural models and language increases the likelihood that more and more people will encounter the same "cultural blind spots"-undetected instances in which prevailing cultural model fails to provide adequate solution to societal problems. Instead, it is by pulling the diverse resources of many understandings that more reliable knowledge can arise, and as Mulhausler (1995a) rightly observes, access to these perspectives is best gained through a diversity of languages. Moreover, it is then obvious that any reduction of language diversity diminishes the adaptation strength of our species because it lowers the part of knowledge from which we can draw.

The language that a people speak is not just a reflector of the biodiversity in a given ecological niche but also a carrier of the people's attitude towards the fauna and flora in that ecology. This language also carries the indigenous knowledge that is the foundation of the knowledge a people presently hold, and which can in retrospect be drawn from to right the wrongs encountered at present such as senseless destruction of environment. Consequently, it is imperative that we listen to the people in the village and learn about what they say, sing and joke about their fauna and flora, and their resilience and adaptability to the obvious climatic changes. We need to learn what their fathers knew and what their

children may never know because of the shifts in language and the loss in ecology.

The physical environment has been suggested by Mulhausler (1996) to be an intrinsic part of the traditional linguistic ecologies in which no separation is felt to exist between an external reality or environment on the one hand and the description of that environment on the other. This again not only underscores the role of language in naming and classification of flora and fauna but also shows the link between the mind and external reality expressed only through language. This leaves one wondering what happens when there are changes in the environment or inversely when one loses the lexicon to describe the existing reality.

As mentioned earlier, languages co-exist, sometimes in the same geographical context. In the Kenyan multilingual scenario three or more languages often exist side by side. This is something that has characterized human history. Humans have spoken a large number of small languages, often many of these languages existing side by side in the same area. In such situations of multilingual contacts, *lingua francas*, pidgins and several local languages have been a common place way of dealing with cross language communication (Muhlhausler, 1996). These incidences may lead to shifts, borrowing and even loss of vocabulary but of significance is that they help maintain linguistic diversity. The Aborigines of Australia and Papua New Guinea constitute especially well known persisting instances of the extensive multilingualism that once characterized human society world over, and that has been a factor in the maintenance of linguistic diversity historically.

Haugen (1972) calls the functional relationship that exists in space and time among linguistic communities that communicates across language barriers 'linguistic ecologies'. He adds that an ecological theory of language has as its focus the diversity of language per-se, and



investigates the functions of such diversity in the history of humanity. He proposes that the mechanisms that have kept linguistic ecologies functioning are the ones a functioning multilingual and multi-cultural society will require (Muhlhauser, 1995b). This means that humans must make informed choices to keep the various languages alive.

These points leave one wondering whether linguistic diversity and diversification may not share substantive characteristic with biological diversity and diversification. At Issue here is the adaptive nature of variation in humans, and the role of language and culture as providers of diversity in humans. Human culture is a powerful adaptation tool, and language at one and the same time enables and conveys much cultural behaviour. Subsequently, the vitality of indigenous languages will be directly proportional to the vitality of biological diversity. Thus the disappearance of species of plants, animals and insects and the destruction of the ecosystem will mean the disappearance of related language and knowledge.

### **Biological diversity and cultural diversity**

There have been a lot of international debates on biodiversity conservation; these have clearly brought out an inextricable link between biological diversity and cultural diversity. What so far has remained outside such debates is the role of language and of the continued presence of a variety of languages in the world in the maintenance of biocultural diversity. This intrinsic and defining role of language in human biocultural diversity is still not well understood in academic, policy making and advocacy circles alike (Maffi, 2005). For this reason, this paper attempts to show the link between language and the environment, and how a loss in one can lead to a loss of the other, Likewise a preservation of one leads to a preservation of the other.

Studies from many disciplines have revealed the inextricable link between cultural,

biological and agricultural diversity at global, national, regional, and local scales (Maffi, 2005). These multidimensional and complex relations are named biocultural diversity. At the local level, this biocultural diversity is revealed through the geographical analysis of the wild plants and animal species, languages, and domesticated organisms. When this is done you get the biocultural heritage of a place.

Studies have also showed that the complex connection between dimensions of linguistic, biological, and agricultural diversity become evident when they are analyzed at a global scale. The correlation revealed is that, in general, the majority of languages and of plant and animal species are situated in the countries that are located within the fringes of the tropics (Oviedo, Maffi, and Larsen 2000) (Check the map on distribution of languages globally on [www.ethnologue.org](http://www.ethnologue.org)). These countries are also the principle centres of domestic animal and plant dispersions.

### **The relationship between language and the environment**

The environment has an intricate link with language. To begin with, the physical environments which are about the geographical structure of an area and are constituted by lakes, landscapes, rainfall etc., do impose certain modes of life on particular communities that befit such environments. In this regard, natural environment is more than just a place where we live because its elements determine our behavior, including our language. Sapir (1912) raised this important point a century ago in this statement:

‘If the characteristic physical environment of a people is to a large extent reflected in its language, this is true to an even greater extent of its social environment’.

(Sapir, quoted in Fill and Mühlhäusler, 2001).

While the physical environment is largely geographical, the social environment is constrained by the demographic or social

factors as pointed out by sociolinguists like Labov (1970), and Fishman (1972) and include age, sex, profession, network etc. These social factors determine the choice of certain linguistic forms over others. Haugen (1972) connects language, physical and social environment by asserting that environment is a piece of evidence that:

‘... might lead one’s thoughts first of all to the referential world to which language provides an index. However, this is the environment not of the language but of its lexicon and grammar. The true environment of a language is the society that uses it as one of its codes. Language exists only in the mind of its users, and it only functions in relating these users to one another, and to nature, their social and natural environment’.

(Haugen, quoted in Fill and Mühlhäusler, 2001)

More recent scholars have supported this intricate link between language and environment. For instance, while commenting on the effects of change of environment on language caused by resettlement of aborigine populations of Australia, Mühlhäusler noted;

‘... the links between language, culture and land were weakened or destroyed, and the languages lost their ecological support systems while the ecologies lost the languages used by their former custodians’ (Mühlhäusler, 2000).

It can be decoded from the above statement that language is central to our conceptualization of our world (interpreting, understanding and changing it) and any changes in the environment leads to changes in language; disappearance of species of plants, animals and insects, and the destruction of ecosystems means the disappearance of related language and knowledge.

Taking the case of Lake Victoria basin and Dholuo language, the Lake Victoria Basin has been and continues to be under extensive impacts of climate change exacerbated by an array of interlinked human activities. Such scholars as Hecky (1984) and Balirwa (1998) observe that the ecology of the lake and fishing processes have changed significantly in the last one decade. In their chronicle of the changes they note that at the beginning of the century the basin was sparsely populated, fishing practices were mainly done using simple traditional methods, and the shoreline was covered in riparian forest. This has changed and at the moment the lake supports intensive fishery using new technologies (e.g., commercially produced, artificial-fibre nets; outboard motors; increasingly destructive fishing gear), human habitation has accelerated, the shore line has been cleared of riparian forest to give way to farmlands and industrial activities, non indigenous fishes such as Nile perch have also been introduced that have influenced the fish composition of the lake. This extremely dynamic situation is still undergoing change. The introduced Nile perch is showing signs of overexploitation, and a subset of the basin fauna is re-emerging. The basin is now prone to floods and droughts. Subsequently, livelihood of the inhabitants of the Lake Victoria basin is changing too.

Dholuo is a language spoken by about 4.4 million Luo people, most of who live in the Eastern shores of Lake Victoria in Nyanza Province of Kenya, and the Tarime area of Tanzania. In Kenya Dholuo speakers constitute about 13% of the population (United States Library of Congress, 2007). Dholuo language is classified as a Western Nilotic sub group of the Nilo-Saharan language family. Until recently, Dholuo had no official status in Kenya and its domain of use include lower primary schools as a medium of instruction, in homes, particularly in the rural areas, in churches and on three radio stations i.e Radio Ramogi, Radio Nam Lolwe and KBC, and in local business.

A lot of Dholuo speakers are multilingual. In addition, they speak English which is the official language, and Kiswahili which is the national language. Dholuo language therefore has some Kiswahili and English words in its lexicon. It is less used in urban households where for political reasons Kiswahili is projected as the default language of communication, and in educational contexts where English is perceived to facilitate social and economic advancement in the face of globalization. This restrictive use of such mother tongue as dholuo is responsible for the declining competence among young people in their first language. However this is being countered to some extent with renewed interest in mother tongue as is evidenced by increasing numbers of vernacular radio broadcasts and periodic vernacular publications. This status of dholuo language in relation to other languages it is in contact with in its environment must be carefully managed so that Dholuo language may not lose to the more 'prestigious' languages in its environment.

Language such as Dholuo plays a major role in all aspects of the speakers' life; it is central to conceptualization of their world; for interpreting, understanding and changing it. As a mother tongue, it gives the Luos the categories to conceive their natural world: any objects, phenomenon, processes or relationships that are important to them are named; and by learning such names they also learn what is vital for them to know in their natural and social environment. For instance, Hunn (1996) points out that named landmarks convey and evoke knowledge both about the physical environment and about the daily human activities, historical events, social relations, ritual and moral conduct. They say 'wisdom sits in places'. Among the Luos of Kenya, names such "Mbugra" implied that the locality has gravely soil; 'kibwayi', a swampy place with acacia shrubs, while 'miranga' implied a dry and un-agriculturally productive area. Currently, most speakers cannot tell the etymology of such names. These no longer

make sense to the speakers and therefore they have lost out on the link between the lexicon and the environment it described.

The Luos are a fishing community, with their livelihood revolving around the Lake Victoria. In 1960, the Nile perch was introduced into the Lake Victoria, the community coined a name for it-*mbuta*-which quickly found its way into the daily discourse of the Luos. They referred to the Nile perch as '*Mbuta Rachandi*' which is loosely translated as the undisturbed Nile perch. This meant they saw it as the unrivalled king of the fishes. Because of its enormous size it got into the communities simile- often big bodies ladies were referred to 'as fat as Nile perch'. The Nile perch was quite a predator, and it quickly led to the apparent loss of 500+ endemic haplochromine species flock that formed the biomass in the Lake. Food chains in the Lake were greatly simplified and the consequence was an increase in eutrophication. Eutrophication led to algae blooms, the replacement of the diatom species by cyanobacteria, deoxygenation as well as the rapid infestation of the water hyacinth (Ochumba and Kibaara, 1989). The loss of this indigenous fish led to loss in vocabulary not just of the fish but also of the characteristic behavior and associations; tools and process involved in fishing, preparation and consumption of such fish. In a nutshell a lot of local knowledge is lost. At the moment, it is only very old members of the community who can name such fishes.

The 80s also saw a rapid infestation of Lake Victoria by the invasive hyacinth weed. The locals named it FORD acronym for the Forum for Restoration of Democracy, which was a mass political movement agitating for political pluralism in the country that rapidly changed the politics of the country. It had similarly taken the country by storm, just like the hyacinth. All these point to the fact that by simply looking at a people's language you easily can deduce their perception of their environment.

Languages are also important in helping us organize our world. Maffi (2002) tells us that words for concepts are like pegs on which we hang the meanings that we store in the storehouse of our minds. Verbalizing helps us remember and reproduce meaning and thus make sense of our reality. Through speaking, we also learn much about our culture's ethics. Alongside the words for objects, processes, and phenomena that we learn, we also learn our cultures connotations, emotions, associations and value judgments. Among the Luos, medicinal plants were treasured and protected; the words that referred to the process of picking the leaves of these plants were '*nguedo yath*' literally translated as pruning the leaves. Normally, this was done cautiously; you were to prune just a few leaves so that other leaves would sustain the natural growth of the plant. Secondly, for the plants whose roots were used, the word for harvesting the roots was '*kunyo yath*' meaning selectively digging out a few roots, as opposed to '*pudho yath*' which implies 'uprooting the plant'. For those plants whose barks were used the word for the process of obtaining the bark was '*pilo kor yien*' meaning to 'split' a piece of the bark. These lexical choices evidently showed not only a community's keenness on preservation of these plants but also the value they attach on them.

Similarly, whenever one needed help from a herbalist he had to pay such token as money, a chicken, grain, bull and so on. This token payment was referred to as '*gir bungu*' literally translated as 'for the bush'. Such a phrase does not only tell about a community's value judgments of the herb/plant but also of emotions associated with such plant. *Gir bungu* as a phrase imply that that particular item, in this case a plant, belong existentially to the bush and the act of removing it or its part was a displacement that called for compensation. This can be compared to marriage where a woman's parents are compensated for the displacement of their daughter. The herbs restored health and well being and as such

were close to the communities' heart. By extension, there was a lot of indigenous knowledge associated with particular plants: where in the physical environment they were found, the seasons when they were available, the other plants or animals that were associated with them. For instance, it's common to be told by the herbalist that 'if you see this plant, or animal then just know that herb X is nearby'. This tells us just how linguistically encoded knowledge about ecological relationships among plants and animals based on observation of interspecific interactions were.

A single plant could have a lot of linguistic and cultural associations and connotations to it. Let us take the case of the bottle gourd (*lagenaria sicerana*) locally known among the Luo as '*agwata*'. Its uses were so varied, and each attracted a different word and connotation. It was boiled or fried as a dish (*budho*), it was eaten as a salad (*Susa*), It could be used as a calabash to hold milk, gruel, honey etc (*agwata*); it was used as a wash basin (*tao*); as a musical instrument (*tun'g/oporo*); as a mask, as a beautiful decoration for houses; as a guard for milk (*koo*); as a spiritual paraphernalia (*puga*). As a milk gourd, it was revered and it symbolized motherhood-reproduction and anchorage. There were sayings such as 'every woman and her gourd', which implied the centrality of a gourd in a woman's life and therefore the family. It was also used as a say when one was in a state of dilemma. Thus, it would be sighed 'A snake has entered into the gourd'. The snake was a symbol of feared evil, while the gourd and milk symbolized virtue. The question then implied; should you smash the revered gourd to kill the snake? This is the dilemma!

As spiritual paraphernalia-the *puga* was used as a medium to commune with the spiritual world. In this regard, it was revered and feared in the same measure. Because of the value and identity the community attached to this species of plant, they named its manifestation and uses. They had narratives and folk songs about it. They preserved it.

However, this is only but orally catalogued. This is evidence of how the indigenous people are a living library. It is also evidence of how the knowledge attached to the fauna and flora naturally led a people to conserve it.

At the moment, the uses of the 'agwata' have been undermined by plastic containers. This admittedly has led to the erosion of cultural knowledge, practices and language surrounding the 'agwata' plant. So with the loss of such names, the species are also lost. Since ours is not a community that largely documents its knowledge in writing, it has to be appreciated that the library of life sciences of these people are in their language and minds of which is highly dependent on biodiversity for their continued existence. In this regard, when such a plant is lost because of changes in the environment then a lot of language and indigenous knowledge is lost with it. Consequently we can say that biodiversity loss equals loss of natural capital and social capital of which the key is language.

From the ongoing, it is noteworthy, that each species of plants and animals, each type of soil and landscape nearly always has a corresponding linguistic expression, a category of knowledge, a practical use, a religious meaning, a role in ritual, and an individual or collective vitality. To safeguard the natural diversity of a place calls for safeguarding the cultures that have given it shape and meaning. The focal point for this is language. Similarly, it is not possible to safeguard cultures while destroying the surrounding nature that support them and gives meaning to their existence. That is a simple but inexorable and vital principle which clearly spells the link between environment and language.

## References

**Balirwa, J. S.** (1998). *Lake Victoria wetlands and the ecology of the Nile tilapia, Oreochromis niloticus*. PhD Thesis. The

Netherlands: Agricultural University of Wageningen.

**Fill, A.** (2001). *Ecolinguistics: State of the Art, The Ecolinguistic Reader: Language, Ecology, and Environment*. Edited by Alwin Fill and Peter Mühlhäusler, (43-53) Continuum, New York

**Fishman, J. A.** (1972). *The Sociology of Language*, Rozley Newbury House Publishers, New York.

**Grimes, B. F.** (ed.). (1996). *Ethnologue: Languages of the world* [thirteenth edition].

**Hecky, R. E., Buganyi, F. W. B., Ochumba, P., Talling, J. F., Mugidde, R., Gophen, M. and Kaufman, L.** (1984). Deoxygenation of the deep water of Lake Victoria, East Africa *Limnol. Oceanogr.* 39:147-148.

**Hunn, E. S.** (1996). Columbia Plateau Indian Place Names: What Can They Teach Us? *Journal of Linguistic Anthropology* 6(1):3-26.

**Labov, K.** (1970) The study of language in its social context. *Studium Generale*, 23: 66-84.

**Maffi, L.** (2002). 'Endangered Languages, Endangered Knowledge.' *International Social Science Journal* 173 (3) 385-393.

**Maffi, L.** (2005). Linguistic, Cultural and biological diversity. *Annual Review of Anthropolgy.* 29:599-617.

**Mühlhäusler, P.** (1995). The interdependence of linguistic and biological diversity. In David Myers *The politics of multiculturalism in Oceania and Polynesia*. Darwin: University of the Northern Territory Press.

**Mühlhäusler, P.** (1996). Linguistic adaptations to changed environmental conditions: some lessons from the past. In Alwin Fill (ed) *Sprachökologie und ökolinquistik*, Tübingen: Staffenbug. 105-30

**Mühlhäusler, P.** (2000). Language Planning and Language Ecology, Current Issues in Language Planning, 1(3): 306-336.

**Mühlhäusler, P.** (2001). *The Ecolinguistics Reader. Language, Ecology and Environment*. London, New York: Continuum.

- Mühlhäusler, P.** (2003). *Language of environment, environment of language: a course in ecolinguistics*. London: Battlebridge.
- Ochumba, P. B. O., and Kibaara D. I.** (1989). Observation on Blue green Algal blooms in the open waters of Lake Victoria Kenya. *Afr. J. Ecol.* 27: 23-31.
- Oviedo, G., Maffi, L. and Larsen, P. B.** (2000) *Indigenous and Traditional Peoples of the World and Ecoregion Conservation: An Integrated Approach to Conserving the World's Biological and Cultural Diversity*, and companion map *Indigenous and Traditional Peoples and the Global 200 Ecoregions*. Gland, Switzerland: WWF-International and Terralingua.
- United States Library of Congress.** (2007). *Country Profile: Kenya* [online]. Available from: <http://www.unhcr.org/refworld/docid/46f9134a0.html>

# Telemedicine: A Digital Public Health Option for Counties and Their Perceived Concerns in Enhancing Healthcare

By  
Asava Tim Kiziiri<sup>1\*</sup>

*1; School of Public Health Maseno University, Private Bag, Maseno*

*\*Corresponding author: [asavatimkiziiri@gmail.com](mailto:asavatimkiziiri@gmail.com)*

---

## Abstract

The delivery of healthcare is unarguably one of the most fundamental needs for Kenya, considering the country's medical nightmare of growing medical problems with an acute shortage of medical facilities and personnel. Despite devolution of health services to the county government an acute shortage of doctors, particularly specialists in Kenya makes it to have fewer health professionals with a doctor patient ratio of 1 doctor per 17,000 patients. Implementation of Kenya e-health strategy 2011-2017 seeks to accelerate and strengthen the gains witnessed in the health sector since 2003. National Health Burden on Maternal mortality is at 488/100000, with Infant mortality at 52/1000 and under five mortality at 80/1000 compared to best managed areas. Adoption of the e-health strategy among counties would transform operations in public health sector and facilitate the country into becoming a hub for accessing specialized health services and achieve universal coverage by 2030. Legal public health application should properly be formulated on the following concerns: perceived threat to the role and status of health-care workers; Fear that telemedicine will only increase the current workload of health-care workers; Fear that telemedicine is market-driven, rather than being user-driven; Fear of technological obsolescence resulting from rapid technological advances; Lack of consideration of knowledge and skills of users; Cultural and linguistic differences. Research into obtaining information about the clinical risks associated with telemedicine should also be assessed.

**Key words:** Telemedicine, Public Health, Counties, Perceived, Health care.

---

## Introduction

The European Commission's Healthcare Telematics Program, EHTO, 2000 defines telemedicine as the rapid access to shared and remote medical expertise by means of telecommunications and information technologies, no matter where the patient or relevant information is located. Telemedicine involves the practice of delivering health care over distance using telecommunications equipment as simple as telephones and fax machines or as complex

as PCs and full-motion interactive multimedia (Huston *et al.*, 2000).

Telemedicine has demonstrated to be an effective way of overcoming certain barriers to care, particularly for communities located in rural and remote areas. In addition, telemedicine can ease the gaps in providing crucial care for those who are underserved, principally because of a shortage of sub-specialty providers.

The delivery of healthcare is unarguably one of the most fundamental needs for Kenya, considering the country's medical nightmare of growing medical problems with an acute shortage of medical facilities and personnel. The Constitution of Kenya Chapter four on the Bill of rights article 43 (1a) states that "every person has the right to the highest attainable standard of health, which includes the right to health care services, including reproductive health care. The WHO ranked that by the end of 2005, HIV/AIDS, malaria, dysentery, cholera, typhoid, yellow fever, and diarrhea; among many others diseases to be affecting most Kenyans. Despite devolution of health services to the county government an acute shortage of doctors, particularly specialists in Kenya makes it to have fewer health professionals with a doctor patient ratio of 1 doctor per 17,000 patients; against WHO doctor patient ratio of 1 doctor to 1000 patients (WHO, 2005). The situation is further worsened by doctors resigning from their duties in some counties in Kenya. The few specialists and services available are concentrated in cities. Rural health workers, who serve most of the population, are isolated from specialist support and up to date information by poor roads, expensive phones and Internet connectivity and a lack of sufficient library facilities (Fraser, 2000).

### **Technological Advances in Telemedicine**

Telemedicine overcomes the barriers of physical distribution of medical resources by bringing medical personnel and expertise virtually to those who need them. In a bid to find a solution to the growing medical problems, many governmental, non-governmental, and international developmental organizations have engaged in an endless effort to implement telemedicine. For example, during the period 1996-2000 the International Telecommunications Union (ITU) organized several missions of telemedicine experts to selected African countries including Kenya. These missions tried to identify Africa's needs and priorities for the introduction of telemedicine services taking into account the

state-of the-art of the local telecommunications networks and their evolution (ITU, 2000).

A satellite network was established that allowed for an interactive video conferencing between medical facilities located in St. John's (Canada) and in Kampala (Uganda) and Nairobi (Kenya). The short-term objectives of the project were to establish an audio-conference link between St. John's, Kampala, and Nairobi, and to enhance medical education and patient care at the Makerere Medical School in Kampala. The long-term goal was to educate people in Uganda and Kenya on the maintenance of a multipoint audio-conferencing technology and to develop distance education programs in healthcare. In December 1985, a satellite link was established in Nairobi, and a similar one in Kampala in February 1986 (Hersh *et al.*, 2001). The system developed out of this linkage was used for several months for pediatric teaching sessions, administrative meetings, transmission of electroencephalography (EEGs), and a variety of other applications. Pediatricians in St. John's were responsible for the majority of the healthcare educational programs, with additional programs hosted by health centers in Ontario and Quebec. In total, more than 400 hours of programming was conducted, and approximately 100 tele-EEGs were transmitted over the satellite, from Nairobi for two months and from Kampala for ten months. EEG specialists in St. John's accurately interpreted the majority of the tracings.

### **The Kenya e-health strategy 2011-2017 and Counties**

It is estimated between 2011 and 2016; global network data will increase by 18 fold (Cisco Visual Network Index, 2012). The implementation of the Kenya e-health strategy 2011-2017 seeks to accelerate the ongoing reforms that are geared towards consolidating and strengthening the gains witnessed in the health sector since 2003. The strategy seeks to address some of the key challenges experienced during the



implementation of the Kenya Health Policy Framework, 1994-2010 and the health sector strategic plans, that include disparities in access between the urban and rural areas and especially the hard to reach areas; the inadequacies of the health infrastructure across the country; the shortages of the human resources for health; the high cost of accessing health for majority of the Kenyans and the limitations in the availability of financial resources for healthcare. It is perceived to accelerate the decentralization of quality health services to rural areas. The e-health strategy facilitates the strengthening of partnerships on the provision of quality healthcare and specialized services. It seeks not only to promote partnerships with the private sector, but also to enable the sector tap into the skills and knowledge on healthcare that exist in the more established institutions both within and outside the country. Towards this end, Kenya will be able to build capacity among its key health personnel through technology transfer and training at minimal cost. The wide use of e-health seeks to open new opportunities for multi-skilling, business and employment. The e-Health Strategy makes use of the already available national ICT infrastructure; conducive policy and legal environment and local expertise that harness ICT for improved healthcare delivery in addition to other ongoing efforts. Efforts seek to fundamentally change the way information is accessed and shared across the health system. The implementation of the e-health strategy is expected to transform operations in the sector and facilitate the country into becoming a hub for accessing specialized health services and achieve universal coverage by 2030. The implementation of telemedicine in the counties has the following advantages: a platform to provide a forum for information transfer and sharing; Promote collaborations and partnerships locally and internationally; Enhance research; Promote specialists consultation, discussions and transfer of skills; Maximize on resource use; and Promote standardization of content. Despite all these, the generic bodies of healthcare such as the

Kenya Medical Practitioner and Dentist Union (KMPDU) and the Nursing Council does not provide for various aspects concerning telemedicine thus raising various public health issues that need to be addressed. This paper seeks to highlight various concerns and implications that may result from the practice of telemedicine.

### **Public Health Concerns and Implications**

Currently there is no proper legislation to protect consumer confidentiality as a mandatory part of the regulatory environment governing procedural or systems development processes to support telemedicine. In addition, providing basic system security and protect against unlawful access or malicious damage to information, every effort must be made to ensure that access is absolutely restricted to authorized persons in accordance with their rights and permissions profile. There exists redundancy in mission critical aspects of telemedicine. This entails putting in place appropriate business continuity mechanisms such as data security and other disaster recovery measures on the doctor-patient/ client information.

Apart from security issue, there are certain problems that come with licensure and credentialing of telemedicine practitioners. This is perhaps due to conflicting interests with regard to ensuring quality of healthcare, regulating professional activities and implementing health policies. Medical malpractice liability may result from uncertainties regarding the legal status of telemedicine existing within and between counties. Similarly, there is increased risk of unauthorized access to patient information. Furthermore regulatory bodies in healthcare such as the Kenya Medical Practice and Dentist Union (KMPDU) have not developed clear rules and regulations governing licensing of telemedicine practitioners. Relationship between health professional and patient is also necessary for success of telemedicine. For example, use of telemedical equipment requires proper training and communicative skills. Lack of this may lead a breakdown in

communication between health professional and patient arising from using a video link. More research is required if the optimum procedure for interacting with patients by video link is to be established. In addition, the following are likely to contribute to the breakdown in communication: Physical and mental factors; depersonalization; different process of consultation; inability to perform the whole consultation; reduced confidence of patients and health professionals; and different knowledge and skills required of health professionals and ergonomic issues. There is the risk that highly skilled staff at the remote site will perceive that their autonomy is threatened by the use of telemedicine, or worse still that they will become no more than technicians, acting solely at the hands of the specialist, who will receive all the plaudits for performing a consultation. There is a wealth of medical information available via the Internet that can be broadly divided into three categories: textbook-style information, produced by medical schools and other academic institutions; abstracts of peer-reviewed articles or whole articles in biomedical journals; health pamphlets and articles intended for the general public, produced by individuals, charitable organizations or special-interest groups. The latter is a major concern as far as patients and other non-health-care professionals are concerned. The content can be biased, inaccurate, confusing and misleading for a patient seeking information about a particular condition. Guidelines should be developed to regulate the production of online medical information specific to patients and the general public. This may involve a review process and an inclusion of 'kitemark' to authenticate accuracy of the information and that it meets regulatory standards. There is a seemingly endless quantity of information available that can affect the quality of the information to healthcare professionals. Currently, the concept of information overload is already a reality for many health-care professionals, since it is nearly impossible to keep up to date with developments. Telemedicine is not an exception as a result of numerous

publications on the subject. Telemedicine is likely to run into the organizational and bureaucratic difficulties that may be counterproductive to the potential for improving health-care delivery. There is lack of interest that exists among the stakeholders including manufacturers, politicians, health administrator and health professionals who could guide and implement such changes.

### **Conclusion**

In future, telemedicine has the potential to augment conventional methods of health care to provide a high-quality health care. This will be achieved principally by increasing equitable access to health information and by improving its exchange throughout the entire health-care pyramid. Such a vision will only be possible, however, if proper legislations are enacted to ensure telemedicine development is dictated by health needs, all applications are properly evaluated, and if they are then integrated into the overall health infrastructure. A solution to this is proper evaluation of any telemedicine legal application on the following: perceived threat to the role and status of health-care workers; fear that telemedicine will only increase the current workload of health-care workers, especially in any transitional phase considering the counties at the moment; fear that telemedicine is market-driven, rather than being user-driven, with the risk of market-driven abandonment of products and technologies; fear of technological obsolescence resulting from rapid technological advances; lack of consideration of knowledge and skills of users; cultural and linguistic differences; and Lack of agreed standards. Research into ways of accessing information about the clinical risks associated with telemedicine should also be assessed. On the balance, the benefits of telemedicine are substantial, assuming that more research will reduce or eliminate the obvious drawbacks.

### **Acknowledgement**

I wish to convey my heartfelt gratitude to Dr. Robert Kei of Moi University- School of

Public Health and my Technical supervisors: Mr. Tom Fred Obaire and Mrs. Jackline Sitienei for their massive input towards the generation of this conference paper.

## References

**European Health Telematics Observatory (EHTO).** (2000). *Compendium of health Telematics projects*. Volume 2:94-98.

**Hersh, W. R., Helfand, M., Wallace, J., et al.** (2001). *Clinical Outcomes Resulting from Telemedicine Interventions: A*

*Systematic Review*. BMC Med Inform Decision Making, 1:5

**Fraser, H. S. F. and McGrath, S. J. D.** (2000). *Economical solutions are available to support health care in remote areas*, British Medical Journal, Volume 321:465-466.

**Huston, T. and Huston, J.** (2000). *Is telemedicine a practical reality?* Communications of the ACM. Volume 43, 6:91-95.

**The Constitution of Kenya.** (2010).

**US Western Governors' Association Telemedicine Action Report.** (1994).

**WHO.** (2005). The World Health Report.

# Peace Through Devolution for Sustainable Development: The Kenyan Case

By  
**Ambuyo Beverlyne Asiko<sup>1\*</sup>**

*1; Department of Kiswahili and other African Languages, Maseno University, P.O. Box 333, Maseno, Kenya*

*\*Corresponding author: [bevily2005@yahoo.com](mailto:bevily2005@yahoo.com) or [bevambuyo@gmail.com](mailto:bevambuyo@gmail.com)\**

---

## Abstract

Good governance is a key pillar to sustainable development of any nation. Many conflicts in Africa can be traced to failure in governance, responsible and accountable management as well as failure to cultivate cultures of peace, especially, engaging in dialogue and reconciliation. Good governance seeks justice and equity for all irrespective of race, gender, religion and any other parameter which man uses to discriminate and exclude. When we manage our resources sustainably and practice good governance we deliberately and consciously promote cultures of peace. In Kenya, governance is expected to be improved through the process of devolution enacted by the Kenya 2010 constitution. This paper seeks to assess the extent through which devolution can be an important ingredient and avenue towards a peaceful Kenya, despite the challenges involved. This is attributed to the expectation that a well-functioning society promotes sustainable development and hence peace.

**Key words:** Governance, Sustainable Development, Devolution, Resources, Peace.

---

## Background

According to a Society for International Development (SID) (2011) report, Kenya is one of the most unequal societies in the world. Disparities in power and resources have often fallen along ethnic lines. Though the country has more than 42 ethnic groups only a handful has dominated the political and economic landscape. It is important to note that Kenya transited into independence with a constitution that provided for devolved governance through a bicameral legislature and regional assembly (Nyanjom, 2011). This was changed by the then ruling party Kenya African National Union (KANU) which had rooted for a unitary state, where all the governing powers had been highly centralized in the executive. Mutakha (2011) observes that the post-

independence governance was evidenced by corruption, ethnic conflict, poverty, insecurity and political uncertainty. Some of the negative outcomes include alienation of large portions of society from the mainstream economy, wasteful public investment, massive poverty, ethnic animosity and cut-throat political competition and intolerance.

Moreover, the first economic blueprint; the Sessional paper No. 10 of 1965, advocated for the focusing of development and investment on the high potential areas on the understanding that the economy would experience rapid growth due to the higher returns on investment in those areas. The policy zoned the country into high, medium and low potential areas. This reinforced the marginalization of the areas that had

suffered neglect during the colonial period. This enhanced inequalities in development through the inclination of resources and job opportunities towards the communities of the economic elites. This allowed them to dispense patronage to both individuals and ethnic communities and it inevitably led to massive abuses of power. The concept of republican government as an instrument in the service of the welfare of the people was no more. Government ceased to serve the people and became the property of a few. Elective and appointive positions became not the means to serve the people but rather, avenues for a massing personal wealth. Allocation of resources and development opportunities was done on the basis of political patronage instead of objective criteria and most important person was the president. The other communities felt that they had been left out in the developmental issues of the country as the national cake was being distributed between the few who were already well off. Such positions in the country led to political unrests as displayed during the 2007/2008 post-election violence. These prompted the quest to fight for better governance by amending various key issues in the Constitution hence the vote in favor of the new constitution in 2010. The main pillar of the constitution being devolution, which divided Kenya into 47 counties, each of which have their own executive and legislative branches of local government. This is believed that it would help solve the governance challenges and economic disparities in Kenya in that there would be local solutions to local problems hence less wastage of resources and misguided priorities. The local government will be responsible for agriculture, transportation, trade licenses, sanitation, pre-primary education, village polytechnics and most health facilities. Though, the overall policy in these areas may still be drawn up by the national government, counties will be in charge of implementation and service delivery.

## **Governance**

The government of any country is the single largest institution that can affect the quality of life of its citizens. Good governance promotes freedom from violence, fear and crime and peaceful and secure societies that provide the stability needed for development investment to be sustained. Previous studies (Pierre, J. and Stoker, G., 2000) observe that Governance is broader than institutions and includes relations between state and people. It provides the mechanisms that collaboration can be generated across sectors. It also addresses some of the fundamental obstacles to sustainable development including exclusion and inequality. Governance processes refer to the quality of participation necessary to ensure that political, social and economic priorities are based on a broad consensus in society and that the voices of the excluded, poorest and most vulnerable are heard in decision making. Outcomes of good governance could be peaceful, stable and resilient society where services are delivered and reflect the needs of communities, including the voices of the most vulnerable and marginalized. Good governance seeks justice and equity for all irrespective of race, religion, gender and any other parameter, which man uses to discriminate and exclude.

In the Kenyan scenario, for many years there had been resentment in the governance structure and practices which prompted the quest to enhance good governance through greater social inclusion in the process of democratic governance, confronting violent extremism, overcoming mass poverty through inclusive growth and addressing the crisis of the environment. Article 174 of the new Constitution recognizes the right of communities to manage their own affairs and further their development. A well-functioning society need to be able to provide for men and women to participate at all levels of governance and sectors of society. This will promote a sense of belonging and unity as they will be involved in finding local solutions to their local challenges.

## **Devolution**

There are two main approaches to the organization and management of state power. The single-dimensional approach which produces a centralized system and structure of government. Second is the multi-dimensional approach which organizes and manages governance as well as state power along multiple lines (Mutakha, 2011). It is founded upon the concept of decentralization and devolution of power. Devolution as a form of decentralization is the statutory granting powers from the Central government of a sovereign state to government at a subnational level such as regional, local or state level. Article 10 (2) of CoK (2010) devolution and sharing of power were identified as values and principle that would guide Kenya governance system. Koki, Chege & Nabulumbi (2011) defines devolution as the transfer of powers from the Central government to local units. Kauzya (2007) explains that decentralization has three fundamental dimensions, which may occur independently, or jointly; the administrative, political and fiscal. Mutakha (2011) observes that devolution is a system that combines self-governance and shared-governance. Self-governance at the local level and shared governance at the national level. Article 6(2) of the Constitution of Kenya describes the government at the two levels as being distinct and inter-dependent and which should conduct their mutual relations on the basis of consultation and cooperation. This is devolution that is not based on the principle of absolute autonomy but instead on that of inter-dependence and cooperation. This system ideally requires that we embrace a system of consultation, negotiation and consensus building if we are to succeed in the running of the affairs of the state.

Mutakha (2011) continues to say that intergovernmental relationships between and among governments therefore, should be based on and informed by these principles of cooperative government. The vertical relationship between national and county government must be on the basis of

cooperative government. Similarly, the horizontal relationships among various county governments must be based on the principles of cooperative government.

### ***The structure and stability of Devolution***

The structure of devolution in Kenya is organized in two levels; horizontally between or among agencies of comparable status like executive, legislature and judiciary and vertically involves the national and local authorities. The stability and success of devolution depends on a proper architecture and design of the system. Nyanjom (2011) seems to agree with Mutakha (2011) that a good devolution structure is characterized by the fact that it is rooted in the supreme law of the land: The constitution. Mutakha continues to explain that a properly designed system will necessarily have the following characteristics:

- Constitutional creation of two or more levels of government with each having sovereignty and directly impacting upon its citizens.
- Constitutional creation of geographic units of governance at the sub-national level into which the country is to be divided and the clear delineation of their boundaries.
- A formal constitutional distribution of governance and development functions of each level of government clearly delineated and ensuring some areas of autonomy for each.
- Constitutional provisions setting out clear rules for the allocation of resources among the levels of government ensuring that each level of government has sufficient resources to enable it discharge its responsibilities.
- Constitutional establishment of governance institutions at each level of government with designated representation of distinct regional views within the national-policy making processes and institutions. Notably, the concept of shared decisions necessitates the creation of some shared institutions.
- A supreme written constitution that is not unilaterally amendable by any one

level of government, but instead, requires the consent of a significant proportion of the constituent units.

- A constitutionally entrenched system of cooperative government with constitutional processes and institutions for facilitation of intergovernmental cooperation and collaboration for the areas where governmental responsibilities are shared or inevitably overlap.
- A constitutionally entrenched system of intergovernmental relationship with provision for dispute resolution, and provision for an umpire, such as the Constitutional or Supreme Court to rule on any disputes between governments.

These characteristics are all pointing towards a harmonious and a workable form of governance where the sets of rule of law and separation of powers are key to all the undertakings at the different levels of government. In addition, in order to enhance cooperation amongst the different government entities peace is compulsory. This is because respect and cooperation can only prevail in a peaceful environment and vice versa. Moreover, the Constitution being the yardstick, there are checks and balances to ensure that there is sanity at all levels of governance.

Chapter 11 (Cap. 11) of CoK (2010) - devolved governments specifically provides for the setting up of the county governments. The chapter explains the various principles of devolved government that includes democratic ideals and separation of powers.

### ***Objectives of devolution***

Article 4 of CoK (2010) adopted republicanism as a key value foundation whereby all authority to govern belongs to and derives from the people directly or indirectly. However, the main objectives of devolution according to article 174 of the CoK (2010) are;

- To promote democratic and accountable exercise of power.

- To foster national unity by recognizing diversity.
- To give powers of self-governance to the people and enhance the participation of the people in the exercise of the powers of the state and in making decisions affecting them.
- To recognize the right of communities to manage their own affairs and to further their development.
- To protect and promote the interests and rights of minorities and marginalized communities.
- To promote social and economic development and the provision of proximate, easily accessible services throughout Kenya.
- To ensure equitable sharing of national and local resources throughout Kenya.
- To facilitate the decentralization of state organs, their functions and services, from the capital of Kenya.
- To enhance checks and balances and the separation of powers.

Moreover, article 175 expresses the principles meant to guide the operations of the devolved governments as:

- The county governments are required to be based on democratic principles and separation of powers.
- They must be availed reliable sources of revenue to enable them to govern and deliver services effectively.
- They must ensure that each of the two genders have at least a third of the members of representative bodies in the county.

If the objectives and principles of devolution stated above can be achieved, then peace and sustainable development will be inevitable in Kenya.

### ***Benefits of Devolution***

Among the more prominent arguments for devolution is the issue of efficiency. The expectation that decentralizing function to the lowest feasible level of decision making and implementation will optimize information flows and reduce transaction

costs. Besides concern with efficiency in service delivery, devolution can also resolve over-centralized misgovernance or defuse secessionist tendencies, its outcome leading to greater consensus in decision (Mwenda, 2010).

Article 203 provides a detailed criteria to be followed in vertically determining the equitable shares of both the national and county governments on the one hand; and horizontally among the 47 counties. These criteria incorporates the principles of financial equalization which must be followed when determining the shares. Article 204 provides for an equalization fund for marginalized areas. Devolved governments can be superior to national ones in providing the means with which to secure the rights and interests of minorities and marginalized groups. It is worth noting that such measure offers a sustainable means even if only implicitly so, of providing affirmative action or positive discrimination for such marginalized groups. In their research Koki *et al.*, (2011) found out that some of the positive effects of devolution are:

- i) Aspects of subsidiarity in that the powers move from the state authority to the county level hence people are assured to be heard if they voice their concerns.
- ii) There will be equal distribution of resources.
- iii) It will lead to the development of individual counties.
- iv) It will lead to the economic growth of the country as a whole.
- v) It will lead to increased employment as new posts that would require human resource.
- vi) It will ease the burden of the central government since the work will have been delegated.
- vii) Decisions will be made faster.

These positive effects are in line with the objectives of devolution. This simply emphasizes the importance of being committed to ensure that devolution succeeds

### ***Challenges of Devolution***

May (2013) in IRIN Africa expresses some of the challenges that lie ahead of devolution including capacity, corruption, conflict and commitment. On capacity, it is noted that there are fears that existing managerial or technical expertise especially in long – marginalized and impoverished parts of the country, will fall out of what's required by effective local governance structure. Additionally, corruption and inter-communal rivalries that decentralization is meant to address could end up undermining the whole process. There are fears that rivalries will lead to the exclusion of minority groups from county level decision making and resource allocation, which could exacerbate tensions between communities, possibly leading to violence.

Moreover, Nyanjom (2011) observed that perhaps the weakest aspect of the constitution with respect to devolution was the failure to rationalize the number of counties beyond the 47 statutory districts which vary widely in area, natural resource endowments and population size. He further noted that these were the same districts that had been used by the previous regimes in power to enhance ethnicity and discrimination.

In their research Koki *et al.*, (2011) also identified some negative effects of devolution as:

- i) It will lead to disunity. This is because a county will be dominated by people from the same ethnic community.
- ii) It will promote ethnicity.
- iii) Corruption might worsen.
- iv) There might be excessive taxation.
- v) The criteria for devolution are not clearly specified.
- vi) It is an expensive form of government.
- vii) It will lead to conflict within ethnic group i.e. nepotism.
- viii) Some areas have inadequate resources to exploit hence they may



continue to lag behind for example the North Eastern part of the country.

- ix) Kenya is too small to be devolved to 47 counties.

The above findings display a thin balance between the benefits and rather the challenges of devolution. It shows the ultimate peace that was to be enhanced might not be achieved if adequate measures are not put in place to ensure objectivity in the whole process of devolution.

The 2010 constitution does address some of these fears, for example article 40 guarantees any citizen the right to acquire and own property in any part of the country. Articles 47 and 48 also guarantee individuals access to fair administrative action and to justice respectively. Part 1 of chapter 5 on the management of land provides avenue to the more equitable management of land. For example, article 60 on land policy emphasizes equitable access to land for sustainable and productive management.

Nevertheless, other provisions that are relevant to enhanced national cohesion include those aimed at reducing ethnic bias in public appointments, which have hitherto been seen as the avenue through which ethnic groups have eaten (Kauzya, 2001). This is important as also noted by Nyanjom (2011) that available literature has shown that ethnic conflict is often fuelled by competition over scarce resources. These are some of the challenges that need to be addressed as devolution is being implemented. Ideally, devolution as a form of governance if implemented cautiously will actually be vital in enhancing knowledge based sustainable development, as the citizens will be involved in all levels and areas of development.

### **Sustainable Development**

Sustainable development ties together concern for the carrying capacity of natural systems with the social and economic challenges faced by humanity. Ulrich (2007) notes that the concept of sustainable

development has its roots in forest management in the 12<sup>th</sup> to 16<sup>th</sup> C. However, over the last two decades the concept has been significantly widened. The first use of the term sustainable in the contemporary general sense was by the club of Rome in 1972 in its classic report on the *Limits to Growth* written by a group of scientists led by Dennis and Donella Meadows of the Massachusetts Institute of Technology. Describing the desirable “state of global equilibrium” the authors used the word sustainable. A model that represents a world system that is sustainable without sudden and uncontrolled collapse and capable of satisfying the basic material requirements of its entire people. The term sustainable development was popularized in 1987 by the United Nations Commission on Environment and Development through the Brundtland Report. That report *Our Common Future*, produced the most widely accepted definition of sustainable development, i.e. development that meets the needs of the present without compromising the ability of future generations to meet their own needs (WCED, 1987). This report says that sustainable development also contains within it two key concepts: first, the concept of needs i.e. the essential needs of the world’s poor to which overriding priority should be given. Secondly, the idea of limitations imposed by the state of technology and social organization on the environments ability to meet present and future needs.

The 1992 Rio declaration presented at the United Nations Conference on Environment and Development noted that sustainability represents an approach to development which addresses the fundamental concerns of poverty, environment, equality and democracy. In principle 25 it is rather clear that peace, development and environmental protection are interdependent and indivisible. Sustainable management and development of resources is only possible if we practice good governance, which calls for respect of the rule of law, respect of human rights, being considerate to the weak and the

vulnerable. Under the principles of the United Nations Charter, the Millennium Declaration identifies principles and treaties on sustainable development including economic development, social development and environmental protection. Agyeman, Bullard and Evans (2003) defines sustainable development as the need to ensure a better quality of life for all, now and into the future, in a just and equitable manner, whilst living within the limits of supporting ecosystems. Basing on the above definitions it is rather clear that sustainable development can be broadly defined as a systems approach to growth and development and to manage natural produced and social capital for the welfare of their own and future.

The earth charter published in the 1992 UN Conference on Environment and Development outlines the building of a just, sustainable and peaceful global society in the 21<sup>st</sup> C. The action plan agenda 21 for sustainable development identified information, integration and participation as key building blocks to help countries achieve development that recognizes these interdependent pillars. It emphasizes that in sustainable development everyone is a user and provider of information. In addition agenda 21 emphasizes that broad public participation in decision making is a fundamental prerequisite for achieving sustainable development. Cultural diversity was also included as one of the pillars for sustainable development as it also a means to achieve a more satisfactory intellectual, emotional, moral and spiritual existence. Participatory democracy and inclusive growth need to be underpinned by the norms and core values that signify unity in diversity. Basing on the pillar of economical sustainable development, it is worth noting that it may involve the improvement in the quality of life for many but may necessitate a decrease in resource consumption. In order to enhance sustainable economic development there is need to build a strong economic base to ensure stability in all the other pillars for sustainable development. Nevertheless, this is also very instrumental in

good governance and the other way round. A government that is economically stable has less issues to deal with in relation to lawlessness hence a peaceful co- existence of its citizens.

Moreover, another indicator of sustainable development as discussed by Scerri and James (2010) is sustainability of human settlement. This is a relationship between human and their natural, social and built environments. This broadens the focus of sustainable development to include the domain of human health. White, Stallones and Last (2013) observes that fundamental human needs such as the availability and quality of air, water, food and shelter are also the ecological foundations of sustainable development. In addition, they express that addressing public health risk through investments in ecosystem services can be a powerful and transformative force for sustainable development which in this sense extends to all species. Agricultural practices should be environment friendly, there should be sustainable provision of energy that is clean and lasting and all in all the activities meet human needs while preserving the life support systems of the planet i.e. ensure that the environment remains diverse and productive

In his study, Paul-Marie (2008) concluded that social indicators and therefore sustainable development indicators are scientific constructs whose principal objective is to inform public policy-making. In Rio (2012) The United Nations Global Compact Cities Programme has defined sustainable political development as a way that broadens the usual definition beyond states and governance. Political sustainability is defined as the domain of practices and meanings associated with basic issues of social power as they pertain to the organization, authorization, legitimation and regulation of a social life held in common. They have listed 7 domains of politics: organization and governance; law and justice; communication and critique; representation and negotiation; security and

accord; dialogue and reconciliation and lastly ethics and accountability. In essence these domains for political sustainability are very pertinent issues for good governance and hence peace and sustainable development in all others areas that affects the functioning and livelihood of a society.

From the above discussion, we can deduce that the pillars for sustainable development encompass economic development, social development and environmental protection. There should be an assurance for continuity in satisfying the basic requirements of all people, a fact that can only be true if there is peace brought about through good governance to enhance development in all areas that affect humanity. These pillars can be encompassed and explained in the whole process and the ultimate desire for devolution in Kenya.

### **Devolution, Peace and Sustainable Development in Kenya**

The pursuit of lasting peace and an end to conflict has become, together with sustainable development, a global imperative. Kaplan (1995) observes that although it might appear intuitive that meeting the basic needs of poor communities holds the promise of eliminating many types of situations which favor the outbreak of conflict, in many cases development can be shown to contribute to or benefit from the existence or possibility of armed conflicts. The concept of sustainable development modifies this relationship considerably. The idea of peace forms an integral part of the idea of sustainable development.

One of the objectives of devolution in Kenya is to protect and promote the interests and rights of minorities and marginalized communities. Nyanjom (2011) observes that devolve governments can be superior to national ones in providing means with which to secure the rights and interests of social minorities and marginalized groups. The measure offers a sustainable means, even if only implicitly so, of providing affirmative action or positive discrimination for such marginalized groups. There is a continuing

debate about how to ensure that the marginalized areas benefit from the pursuit of economic growth and identifying the right level of governance for linking economic development and social inclusion policies. PMSU (2005) noted that people living in deprived areas are more likely to be worse off than similar people living in more prosperous areas. They are less likely to work, more likely to live in poorer housing in unattractive local environments with high levels of anti-social behavior and lawlessness and more likely to receive poorer education and health services. Together these can create a cycle of decline or ensure that already deprived areas remain that way. This concurs with the marginalized areas and the various slums found in the major towns in Kenya. These places are highly volatile and any slight instability leads to violent break outs. This point to the need for different types of intervention at different levels as the basic requirements of governance arrangements that have the necessary sensitivity and flexibility to address the economic needs of such areas. There is need for the various local governments in the devolved system to have workable policies towards ensuring that the conditions in such areas have been uplifted and jobs created in order to reduce tension and make people living in those areas have a meaningful life.

In terms of economic development, national and regional economic strategies need to pursue an agenda focusing on promoting economic competitiveness within a knowledge based global economy, This should be done having the interests of all areas of the country at heart, be it in the highly developed or under developed regions. A well working devolved system should be able to handle this, given that it is one of its objectives as stated above. Need for wide range of other national and regional strategies related to employment and skills, education, housing, transport and spatial development that play an important role in addressing the economic needs of the marginalized areas either explicitly or more

often implicitly through their agenda setting, funding provision and delivery mechanism, even though the limitations of local capacity and infrastructure in some areas may be a likely barrier to progressing and deepening a devolution approach in Kenya.

Article 6 provides for distinct and inter-dependent governments that must conduct their mutual relations on the basis of consultation and cooperation. Nevertheless, Article 189 also recognizes and provides for cooperative government that must respect each other's constitutional functional and institutional jurisdiction and must cooperate with each other. With the central powers moving closer to the people, they will be more confident in the government. This is because with the inter-governmental cooperation they will be sure of their concerns being heard and attended to in time. This will promote peace since there will be lesser cases of strikes and other rebellious acts.

Despite administrative decentralization, regional structures remain powerless in relation to the wider global economic forces driving processes of regional change.

The bulk of public spending comes from the central government programs, only some of which is channeled to the regional government officer. Limited powers, resources and capacities continue to constrain the ability to transform priorities and strategies into effective practice. Moreover, the human resource capacity must be well developed for meaningful development to be realized. Atkinson (2010) seem to agree with the discussions expressed by ILO (2008) that one way of doing it is by paying greater issues affecting labor market participation among marginalized groups, in that the numbers and quality of jobs within lower skilled sectors that provide entry level opportunities and the possibilities of progression within these jobs. In reality the low pay of many of the jobs does not guarantee a move out of poverty, while many of these jobs offer few prospects for upward skilling and mobility.

The devolved governance seems more promising in creation of jobs opportunities; the only greater challenge to this is its ability to transform priorities and strategies into effective practice. In addition, the issue of who knows who in order to be given a particular job opportunity, whether qualified or not should not arise as various employment structures and strategies should be put in place to curb this. Such forms of corruption may derail the sanity and peace that may be brought about by devolved form of governance.

There is also greater need for clarity over roles and responsibilities of various governance bodies. It's all about encouraging existing bodies to establish effective, long-term working relationships and leadership roles as appropriate to local or regional context. Furthermore, devolution of central government powers and resources to local and regional bodies is required in order to deliver effectively in response to their local needs and priorities rather than merely delivering central government targets. Various regions of Kenya are characterized by big socio-economic disparities hence a need for institutional arrangements with the ability to develop structures, processes and outputs that are locally appropriate and not centrally imposed if sustainable economic development is to be achieved. At those local levels, an inclusive and highly accountable form of governance should be encouraged if satisfaction and peaceful co-existence is to be realized.

Devolution has further been seen as an avenue to democratic deepening within the country, with constitution or legal boundaries diminishing friction as there is clear cut distinction of the responsibilities of the different levels of governance. For example chapter 11 of the C. O. K. (2010) enhances the scope for democracy, self-governance and self-management giving checks and balances on individual excesses on leadership as is always experienced in the political arena. Nevertheless, the citizens are at the center of decision making in

challenges that directly affect them since they are part and parcel of the immediate solutions to be adhered to within a particular jurisdiction, be it in education, health, transport and communication, leadership, industrialization, environmental amongst other developmental projects.

## Conclusion

Devolution in Kenya is fundamental to promoting greater coordination of activity and the peaceful engagement of a wide range of localized stakeholders through governance arrangements that are transparent, open to a range of interests and have legitimacy rooted within the wider democratic process. The various objectives of devolution in Kenya are all a key indicator to the respect to humanity and the desire to enhance peace at all levels of governance. The principle of cooperative government being pivotal to ensure peace horizontally amongst various county governments, and vertically between the national and county government. This brings in the need for respect and a clear cut of each level's responsibility in governance as stipulated in the CoK (2010). However, despite the fact that devolution can respond to heightened ethnic differences it is important to recognize its limitations as a solution that contains, rather than eliminates diversity. All this should be cautiously and flexibly adhered to, to ensure social, economic, political and environmental development and hence sustainable development in Kenya.

## References

- Agyeman, J., Bullard, R. D., and Evans, B.** (Eds.) (2003). *Just Sustainabilities: Development in an unequal World*. Cambridge MA, USA: MIT Press.
- Atkinson, I. A.** (2010). *Governance structures and the devolved delivery of employment outcomes*. [http://www.gov.uk/government/uploads/system/uploads/attachment\\_data/file/214449/rrep678.pdf](http://www.gov.uk/government/uploads/system/uploads/attachment_data/file/214449/rrep678.pdf)
- Atkinson, R., and Kintrea, K.** (2001). 'Disentangling area effects: evidence from deprived and non-deprived neighborhoods.' *Urban Studies*, vol.38 (12) p 2227-2298.
- Brundtland Commission**, (1987). *Report of the World Commission on Environment and Development*. United Nations.
- Constitution of Kenya.** (2010). *Laws of Kenya*. Published by the National Council for Law Reporting with the Authority of the Attorney General.
- G.O.K.** (1965). *Sessional Paper Number 10 on African Socialism and its application to Planning in Kenya*. Nairobi: Government printers.
- International Monetary Fund.** (2007). *World Economic Outlook 2007: Globalization and Inequality*. Washington, D.C.: International Monetary Fund.
- Kangu, M.** (2011). *Operationalization of Devolution in the Constitution of Kenya*. A presentation at a workshop held at Strathmore Business School on the 22<sup>nd</sup> March, 2011. [www.strathmore.edu/pdf/mutakha-devolution-kenya.pdf](http://www.strathmore.edu/pdf/mutakha-devolution-kenya.pdf)
- Kauzya, J. M.** (2007). *Political Decentralization in Africa: Experiences of Uganda, Rwanda & South Africa*, UN Department of Economic and Social Affairs, New York.
- Koki, M., Chege, N. B., and Nabulumbi, L. W.** (2011). *Devolution & National building*. Strathmore University. [www.strathmore.edu/ethics/pdf/DevolutionNationBuildingSUI.pdf](http://www.strathmore.edu/ethics/pdf/DevolutionNationBuildingSUI.pdf)
- Labor Organization.** (2008). *International World of Work Report 2008: Income inequalities in the age of financial globalization*. Geneva: International Institute for Labor Studies.
- May, A. L.** (2013). *Briefing: Devolution to transform Kenya* [www.irinnews.org/fr/report/97726/briefing-devolution-to-transform-kenya](http://www.irinnews.org/fr/report/97726/briefing-devolution-to-transform-kenya) Accessed on 15<sup>th</sup> June, 2014.
- Mwenda, A.** (2010). Introduction in IEA Devolution in Kenya: Prospects, challenges and the future, IEA Research

- Paper series no. 24. Nairobi: Institute of Economic Affairs.
- North, D., Syrett, S., and Etherington, D.** (2008). *Devolution and Regional Governance: Tackling the Economic needs of deprived areas*. Joseph Rowtree Foundation. [www.northamptonshireobservatory.co.uk/docs/doc2127-devolution-governance-deprivation080327121254.pdf](http://www.northamptonshireobservatory.co.uk/docs/doc2127-devolution-governance-deprivation080327121254.pdf)
- Nyanjom, O.** (2011). *Devolution in Kenya's New Constitution, Constitution working paper number 4*. Nairobi: SID [www.sidint.net/docs/wp4.pdf](http://www.sidint.net/docs/wp4.pdf) Accessed on 15th June 2014.
- ODPM** (Office of the Deputy Prime Minister) (2005). *National Evaluation of LPSs: LPSs, Multi-level Governance and Economic Development*. London: ODPM.
- OECD** (2010). *Development Cooperation Report*. Paris: OECD. <http://www.oecd.org/document/63/0,3343,en-2649-333721-42195902-1-1-1-1,00.html>
- Pierre, J., and Stoker, G.** (2000) 'Towards multi-level governance', in P. Dunleavy, A. Gamble, I. Holliday and G. Peele (eds.) *Developments in British Politics 6*. London: Macmillan, 29–46.
- Rio de J.** (1992). *Declaration on Environment and Development*. <http://www.unep.org/Documents/MultiInguual/Default.asp?documentid=78&articleid=1163>
- SID.** (2011). *Devolution in Kenya's new Constitution. Constitution working paper no. 4*. SID, Nairobi. [www.sidint.net/docs/wp4.pdf](http://www.sidint.net/docs/wp4.pdf)
- Scerri, A., and James, P.** (2010). Accounting for Sustainability: Combining Qualitative and Quantitative. *International Journal of Social Research Methodology*, 13 (1).
- Ulrich, G.** (2007). *Deep roots: A conceptual History of Sustainable Development*. Wissenschaftszentrum. Berlin: für Sozialforschung.
- United Nations.** (2010). *The Millennium Development Goals Report 2010*. New York: United Nations.
- UN Economic and Social Affairs.** (2006). *Trends in Sustainable Development*. New York: United Nations.
- White, F., Stallones, L., and Last, J. M.** (2013). *Global Public Health: Ecological Foundations*. Oxford University Press.

# Knowledge Economy as a Way of Securing Peace and Sustainable Development in the 21<sup>st</sup> Century

By  
Constance Ayabei<sup>1\*</sup> and Dickson S. O. Owiti<sup>2</sup>

*1; School of Arts and Social Sciences, Rongo University College, Rongo*

*2; School of Education, Rongo University College, Rongo*

*\*Corresponding author: [constance.ayabei@gmail.com](mailto:constance.ayabei@gmail.com)*

---

## Abstract

Knowledge economy is where organizations and people acquire, create, disseminate, and use knowledge more effectively for greater economic and social development. Knowledge therefore provides great potential for countries to strengthen their economic and social development, thereby providing more efficient ways of producing goods and services and delivering them more effectively and at lower costs to a greater number of people, thus enhancing peace. Finding peace is certainly the greatest collective challenge that every society has ever faced since violence and war is a product of uneven distribution of resources and culture. In order to direct our cultural mindsets towards sustaining peace and development, the energy stemming from these violence can be directed towards achieving positive change if universal values of peace, non-violence, tolerance and respect for human rights are incorporated into all education curricula. A society that promotes education to its members promotes availability of resources and makes progress towards peace by channeling skills and energy into programs that rebuild the community and strengthen bonds between communities. Peace education can inspire people to look to the future for a better tomorrow. Education empowers members of a society to form opinions and act on issues concerning societal development. Another way of securing peace and development is through economic stability. The uneven distribution of benefits: economic growth, modernization and employment, has resulted in an increased gap between members of society and therefore presents an elusive threat to peace and development. The creation of peace is a long, ongoing process that can take years to accomplish, but at least the generations to come will have the chance to experience its benefits. It must become our united effort as human beings to ensure EFA goal is realized for peace, harmony and prosperity.

**Key words:** knowledge economy, resources, culture and peace

---

## Introduction

War has been a constant threat to mankind since the dawn of civilization. Certain regions of the world have experienced more unrest than others even in the recent past. The Global Peace Index (GPI) for 2011

suggests that the world has become slightly less peaceful. While some parts of the world have, in the 21<sup>st</sup> Century, moved towards greater co-operation, political and economic stabilities, others have remained a cauldron of instability and economic deprivation.

Africa for instance, has not only been classified as developing but also as a dark continent in which poverty has various underpinnings and in which the light that flickers at the end of the tunnel is that of desperation (Kok Report, 2004).

Knowledge economy is where organizations and people acquire, create, disseminate, and use knowledge more effectively for greater economic and social development. It covers every aspect of the contemporary economy from high tech manufacturing and ICTs through knowledge intensive services to the overtly creative industries such as media and architecture (Kok Report, 2004). Peace and sustainable development in the 21<sup>st</sup> century is increasingly based on the effective utilization of intangible assets such as knowledge, skills and innovativeness (Kok Report, 2004). Economic growth is today increasingly driven by knowledge than ever before and no country can remain peaceful and competitive without applying the knowledge and skills of her citizens (Kok Report, 2004).

Education systems and digital divide across the globe is creating knowledge and economic divide. This has resulted in striking disparities between rich and poor countries in their investment and capacity in science and technology (Kok Report, 2004). The poorest regions of the world have the lowest access to education hence leading to low level of knowledge economy. This scenario has resulted to uneven distribution of the dwindling resources thereby causing conflicts and wars (Kok Report, 2004). Sustaining peace and development in the 21<sup>st</sup> Century has been elusive due to poverty, different political, religious and cultural ideologies (Kok Report, 2004). This paper focuses on how knowledge economy as a prerequisite for sustainable development is linked to peace. In order to achieve this, we need to adapt a renewed mindset that promotes relevant quality education leading to innovations and technological advancement that ensures efficient production of goods and services and their

delivery to a greater number of people. This is hoped will promote a culture of peace.

### **Knowledge Economy**

Knowledge refers to all types of understanding gained through experience or study, whether indigenous, scientific, scholarly, or otherwise non-academic (Reichmann and Franklin, 1999). Knowledge is cumulative, inelible ideas in whatever form in which it is expressed or obtained. Some scholars view knowledge as a commodity and as a constitutive force of the society (Barman, 1989). Knowledge is recognised as the driver of productivity and economic growth since all sectors of the economy are reliant on knowledge generation, and a source of innovation (Bell, 1973).

The initial foundation for knowledge economy was introduced in 1966 in the book 'The *Effective Executive* by Peter Drucker. It is where organizations and people acquire, create, disseminate, and use knowledge more effectively for greater economic and social development. It provides great potential for countries to strengthen their economic and social development, thereby providing more efficient ways of producing goods and services and delivering them more efficiently and at lower costs to a greater number of people, and therefore enhancing peace (Reichmann and Franklin, 1999).

While most developing countries have committed themselves to EFA and universal primary education goals, the idea has in most cases become economically costly 'sacred cow' and have yielded less fruits due to economic disparities, thus widening the rate of unemployment to staggering proportions (Reichmann and Franklin, 1999). The 'educated' have increasingly joined the ranks of those without jobs. This brings conflict in the society because of uneven distribution of wealth. Besides, developing countries face problems in adapting their education system to meet the challenges of the knowledge economy due to insufficient funding to develop high



education programs in science and technology, insufficient education strategies for marginalized group, lack of schools in remote areas and failure to incorporate peace education in the education curriculum (Reichmann and Franklin, 1999). This is besides the fact that education increases productivity and competitiveness while peace education enables individuals to function as agents of peace and economic change in their societies (Reichmann and Franklin, 1999). On the role of education in the development of new countries Nyerere asserts:

‘Education in a developing nation is to contribute to ideas, manpower, and service for the furtherance of human equality, human dignity and human development’.

Quality education is necessary for knowledge economy so as to provide more efficient ways of producing goods and services and delivering them more effectively and at lower costs to a greater number of people thus enhancing peace. In most developing countries, education is seen as the key to development and alleviates poverty. It starts with universal primary education as well as dynamic system of secondary and tertiary education. Most developing countries have committed themselves to the goal of universal primary education, which in most cases has become economically costly. The idea has yielded less fruits because economic disparities have continued to widen and the rate of unemployment has reached staggering proportions, with the ‘educated’ increasingly swelling the ranks of those without jobs.

Most developing countries who are members of Organization for Economic Cooperation and Development (OECD) spend some percentage of their GDP in education so as to increase knowledge economy. Korea is an example of an OECD country experiencing significant economic growth since 1960’s due to an increase in percentage of GDP spent in education.

The fundamental recognition of education for peace makes the education of girls and women a central process of development. In most developing countries, girls and women are denied access to education hence cannot function as agents of peace and economic change in their societies. It promotes peace for good management of resources and assets, mobilization of revenue and investment thus stimulating economic transformation. The world needs peace, strong leadership and knowledge economy to be ready to exploit the benefits from globalization. Good governance and democratization would encourage accountability, responsiveness to peoples’ needs owing to the prioritizing of what they need more than others.

The World economy remains underdeveloped despite decades of conceptualizing, formulating and implementing various types of economic policies and programmes. For instance, Africa remains in the list of developing economy because it contains a growing share of the world’s absolute poor with little power to influence the allocation of resources. High inequality, uneven access to resources, social exclusion, insecurity, environmental degradation, HIV/AIDS pandemic, among others are some of the development challenges facing the continent. Given that the violence and war is a product of culture which results in underdevelopment, we can modify our basic cultural mindsets towards creating a culture of peace. We must strive to build a culture which consists of values, attitudes and behaviors that reject violence. Knowledge economy can help us achieve this.

### **Peace**

Peace can be defined as the achievement of harmony by the absence of war or conflict. It can also be defined as “freedom from civil clamor and confusion (Websters, 1993). Peace is a situation where mental or spiritual conditions are marked by freedom from disquieting or oppressive thoughts or emotions. It is a tranquil state of freedom

from outside disturbances and harassment as peace creates harmony in humans. Johan Galtung proposed distinction of peace as 'positive peace' and 'relative peace'. 'Negative peace' refers to the absence of war and violence, whereas positive peace refers to the presence of the conditions that eliminate the causes of violence and build peace. Promoting peace means promoting a culture of peace.

The Global Peace Index (GPI), *which gauges ongoing domestic and international conflict*, for 2011 suggests that the world has become slightly less peaceful. Some nations are experiencing an intensification of conflicts and growing instability which are linked to rapid increases in fuel and food prices as well as terrorism. In the Global Peace Index of 2011, Iceland is ranked as the top country most at peace while Iraq and Somali have been ranked the countries least at peace. Small, stable and democratic countries are consistently ranked more peaceful.

Sustaining peace in the 21<sup>st</sup> Century is imperative to any developing country. Lack of peace is costly economically and socially since a society diverts its resources from productive to destruction. For instance, during civil wars, governments increase their military expenditure thus reducing economic growth. Sustaining peace through knowledge economy brings about equality and good governance which are necessary for economic transformation. A peaceful climate stimulates good management of resources and assets, mobilization of revenue and investment which are necessary for economic growth.

Knowledge economy exploits the benefits for globalization. Advances in bio-technology, innovations, science and technology accelerate and strengthen nation's economic and social development. Good governance and democratization would encourage accountability, responsiveness to peoples' needs owing to the prioritizing of what they need more than others.

## **Development**

According to Todaro (1992), development is the capacity of a national economy, whose initial economic condition has been more or less static for a long time, to generate and sustain an annual increase in its Gross National Product at rates of perhaps 5 to 7% or more. Development is both physical reality and a state of mind in which society has, through some combination of social, economic and institutional processes, secured the means for obtaining a better life (Todaro, 1992).

Development in all societies must have an objective of raising levels of living, including provision of better education and more attention to cultural and humanistic values. In this case, knowledge therefore serves to enhance material well-being as well as generating individual and national self-esteem which will bring sustainable peace and development. Knowledge economy is imperative since it expands the range of economic and social choice to individuals and nations by freeing them from servitude and dependence not only in relation to other people and nation-states but also to the forces of ignorance and human misery which will bring peace and development.

### **i. Knowledge and Economic development**

The human resources of a nation, and not its capital or material resources that ultimately determine the character and pace of its economic, political and or social development. Knowledge economy constitute the ultimate basis of wealth of nations for it leads to accumulation of wealth, exploitation of natural resources and build economic organizations as well as carrying out national development. Clearly, a country which is unable to develop and promote knowledge economy will be unable to develop anything else (Harbison, 1973). Thus knowledge economy plays a vital role in bringing peace in the society. It secures sustainable development since economic growth is closely linked to the maintenance of peace. Globalization has resulted into

countries close connectivity and interdependence hence economic stability is an essential requirement for development. Uneven distribution of benefits: economic growth, modernization and employment, has resulted in an increased gap between members of society and this has threatened peace.

Equality in economic opportunities and creating more employment will enable majority members of society to obtain a decent living and getting out of the cycle of poverty. Unequal access to education prevents them from obtaining skills that would contribute to their development and self-sufficiency. Economic growth results not only from growth in quantity and quality of resources and improved technology but also from a social and political structure that is conducive for peace in the society. Economic growth requires an environment which is capable of resolving the inevitable conflicts. For example, a shift from a large landlord to a smaller farmer may involve conflicts of interest. Thus there is need to promote knowledge economy of developing countries because they constitute the majority of the world's people. If there is no knowledge economy, global economy will become increasingly threatened hence development will not be sustained.

### **ii. Social development**

Social issues with impact on the maintenance of peace includes changes in people's lives such as the breakdown of family structures, migration to areas that lack appropriate sufficient infrastructures, loss of traditional values as a result of isolation that follows from the breakdown of personal history, exposure to violence in the media as well as in daily life and the exposure to different cultures. As Pope John Paul II observed in Brazil in 1980:

A society that is not socially just and does not intend to be puts its own future in danger.

Advances in technology have enabled millions of people to enhance their mobility anywhere in the world, resulting in exposure to diverse cultures and making societies increasingly multi-cultural. But this process has brought drawbacks with its many benefits as well. It can provoke fear and rejection of the unknown, misunderstanding and intolerance of other cultures if not properly integrated.

### **iii. Political Development**

Politics also influence development. A country which has good political structure has sustained development. Developed and developing countries have different nature of political institutions. Before their industrial revolution, developed countries were independent consolidated nation-states able to pursue national policies on the basis of a general consensus of popular opinions and attitude towards 'modernization'. As Professor Myrad (1970) has correctly pointed out:

'Developed countries formed a small world of broadly similar cultures, within which people and ideas circulated rather freely. Modern scientific thought development in these countries (long before their industrial revolutions) and a modern technology began early to be introduced in their agriculture and their industries, which at that time were all small-scale'. pp. 30-31.

Even after their independence, many developing countries have experienced political conflicts. They have not yet become consolidated nation-states with the ability to formulate and pursue national development strategies effectively. Promoting knowledge economy means having flexible political institutions which are able to formulate and pursue national development strategies which will bring peace. Political stability is closely linked to the prevention of conflict and the promotion of peace. In order to secure peace for sustainable development, political systems should promote democracy,

and human rights. This does not promote corruption, injustice and abuse within the society. Totalitarian regimes force their own values and beliefs upon members of the society through the use of state-controlled media. This abuse of human rights is correlated with low life expectancies and high mortality rates, deterioration of the environment and the drain of labor and capital resources.

Peace cannot be maintained if there is injustice and disparity in the society. Countries should promote the values of democracy that provide empowerment to the people, the ability to influence policy, protect human rights and most importantly, hold the government accountable. Promotion of democracy prevents conflict, strengthens governance, improves the rule of law and creates stability. Society must therefore embrace the democratic values of openness and equality. An open society tolerates differing perspectives. No single group, government or organization has a monopoly on truth. Government and civic society must remain open to change in order to adapt to the increasingly interconnected world.

We must work together and intervene to eliminate conditions of poverty and inequality, even if it does not concern us directly. This is essential to the future of peace as oppressive regimes affect negatives the entire international community. There is no place for oppressive regimes in an interconnected global open society.

### **Strategies for Securing Peace and Sustainable Development through Knowledge Economy**

Developing countries face challenges adapting their education systems to promote knowledge economy due to lack of sufficient funding to review and develop education programs that enhance technological advancement and innovativeness. Managements of developing countries should show strong and continued commitment to EFA and Millennium Development Goals (MDG'S). Apart from

being more entrepreneurial in their financing sources and modalities, governments should also make tertiary and higher education more affordable via loans, scholarships and bursaries.

To promote knowledge economy, developing countries need to restructure their education curriculums to promote quality education. The governments should create centers of excellence with special and high quality research and development programs. There is need to transform teacher education curriculum as well as learning from memorization and teacher-directed to collaborative modes that creates knowledge economy in the society. The potential for information technology should be fully exploited. The governments should provide funds to schools, colleges and Universities so that they can fully exploit ICT, as it plays a crucial role in the society because it leads to diffusion of knowledge.

Besides, governments should take active participation in UNESCO's Associated Schools Project in primary, as well as secondary, levels of education. This is where learning materials are provided to schools and focus is on four main themes namely; World Concerns and the United Nations system, Human Rights and Democracy, Intercultural Learning, and Environmental Issues, all to enhance a culture of peace. There is need to embrace a culture of peace incorporating values, attitudes and behaviors that reject violence. It envisages tolerance and promotes justice. Establishing a strategy to promote peace and sustainable development through education can be accomplished through the incorporation of the universal values of tolerance and respect for human rights, gender, democratic participation, open communication and international security.

Parents and teachers can play a major role in the reduction of conflict. Children and youth are desperately in need of mentors that can teach them the values of tolerance and compassion. When children leave their

schools, they also need to be exposed to the values of peace within their home and in the larger society. This requires that education programs be created not only for children, but also for parents and for the society as a whole.

Cultural activities create social bonds between different segments of society, giving them common interests and background. Sporting events are a universal example of people setting aside their interests to accomplish a unified goal. Art activities stimulate members of the society to express themselves in a similar way. Cultural activities such as artistic expression can work towards bonding people together. Organizations can work so that the message of peace can be incorporated into these activities.

The role of the media is even more important as our world develops its infrastructures and becomes ever more global. The media must place emphasis on moral values, actively cooperate with organizations, utilize all available resources to disseminate the message of peace, tolerance, non-violence, respect for human rights and the promotion of democracy.

In order to promote knowledge economy, Scientists must work towards the creation of technologies that will benefit everyone and equalize standards of living. The transition to a technology and information-oriented society must not be isolated to the select few. Corporations must initiate, and contribute, to these causes. These enterprises have the monies, and therefore the ability, to provide a powerful contribution towards programs and projects aimed at eliminating the unequal distribution of wealth and resources throughout the world.

Regional cooperation and regional integration is required in order to achieve peace. Regional cooperation leads to social and economic interaction (Hurrell, 1995). It produces interdependence which will deepen perceptions of common interest and identity

which will promote peace and regional cohesion.

### **Conclusion**

The creation of knowledge economy is a long, ongoing process that will take years to accomplish, but at least the generations to come will have the chance to experience its benefits. It must become our united goal as human beings to live with one another in peace and harmony. Knowledge economy will be realized if education systems include peace education as part of the curriculum. Peace education will build social cohesion which will lead to development. Changes should include a need to nurture competencies for the knowledge society such as the need for EFA, incorporating ICT in early childhood, secondary, tertiary and teacher education to enhance innovativeness.

Learning assessment results shows children are not learning what they should in school (Uwezo, 2014). There is need to embrace teaching learning practices that support development of skills. States should unite and help fragile states to emerge successfully from crisis and conflict and consolidate peace, in the spirit of the UN Charter. A crucial step towards rethinking development is to recognize the existence and experience of peace as one of the preconditions for world development in the 21<sup>st</sup> Century.

A culture of peace involves values, attitudes and behaviors that reject violence. It envisages tolerance and promotes justice. Establishing a strategy to promote peace and sustainable development through education can be accomplished through the incorporation of the universal values of tolerance and respect for human rights, Gender, democratic Participation, open communication and international security.

### **References**

**Balanandan, E.** (1998). *Social development, including questions relating to the world social situation and to youth, ageing, disabled*

persons and the family. Statement by Member of Parliament of the Third Committee on Social, Humanitarian and Cultural Issues, United Nations.

**Chingono, M.** (1996). "Introduction", in *The State, Violence and Development*: The Cock, Jacklyn, 1998. Cape Town: David Phillip.

**Khamphuis, B.** (2005). "Economic Policy for Building Peace", in *Postconflict* Kofi Annan's (1997) address to UNDP conference on governance for sustainable development, New York.

**Myrdal, G.** (1970). *The Challenges of World Poverty*, Pantheon New York, pp.30-31

**Obadan, M. K. I.** (1998). *The State, Leadership, Governance and Economic Development*: Oxford: Oxford University Press, London.

**Todaro, M.** (1992). *Economies for a developing World. An introduction to principles, problems and policies for development*. United Kingdom: Prentice Hall.

**World Bank.** (2005). *Global Economic Prospects 2005: Trade, Regionalism, Development*, Washington DC.

**Zurn, M.** (2004). 'Global Governance and legitimacy Problems' *Government and Opposition*, 39(2).

**International Development Research Centre (IDRC)**  
[http://www.idrc.ca/en/ev-71762-201-1-DO\\_TOPIC.html](http://www.idrc.ca/en/ev-71762-201-1-DO_TOPIC.html).

**UNESCO** ([http://portal.unesco.or/education/en/ev.php-URL\\_ID=31059&URL\\_DO\\_TOPIC&URL\\_SECTION=201.html](http://portal.unesco.or/education/en/ev.php-URL_ID=31059&URL_DO_TOPIC&URL_SECTION=201.html)).

**World Bank**  
<http://web.worldbank.org/WBEITE/EXTERNAL/COUNTRIES/AFRICAEXT/EXTPUBREP.EXTSTATINAFR/0,contMDK:21106218~menuPK:824080~pagePK:64168445~piPK:64168309~theSitePK:824043,00.html>.

# Village Elites and Community Development in Kenya

By

George M. Onyango<sup>1\*</sup> and Lillian A. Omondi<sup>2</sup>

*1; Department of Urban and Regional Planning, Maseno University, Private Bag, Maseno, Kenya*

*2; Department of Sociology and Anthropology, Maseno University, Private Bag, Maseno, Kenya*

*\*Corresponding author: <sup>1\*</sup>[georgemarkonyango@yahoo.com](mailto:georgemarkonyango@yahoo.com) and <sup>2</sup>[lilomondi@yahoo.co.uk](mailto:lilomondi@yahoo.co.uk)*

---

## Abstract

This paper looks at the role of village elites in a rapidly changing rural landscape. The process of development in Kenya has seen the rise of a dichotomous community in which salaried employees spend their working life in the urban areas and on retirement move to the rural areas. There are also a large number of civil servants, teachers and religious leaders employed and based in the rural areas. These two sets of people have significant control of how development interventions operate in the rural communities. The result is that often their aspiration may not represent the bulk of the community. To achieve the broad goals of Kenya Vision 2030, there is an urgent need to effectively utilize the resources like manpower, skilled and unskilled, available in the country. These village elites form a critical element of skilled labor in rural development. The paper aims at assessing the roles of the different categories of elites in the rural communities, examining their capacity to influence the development agenda and the impact of this role in effectiveness of development interventions. The paper highlights challenges that development agencies need to address with regards to village elites community as they endeavor to maximize the contribution of these elites to effectively enhance rural development.

**Key Words:** Village Elites, Social Capital, Community Development

---

## Introduction

Kenya aspires to be a middle-income country by 2030. The Vision 2030 is the framework that the Government is using to guide all development within the country. To achieve the broad goals of Vision 2030, there are various efforts that need to be developed to utilize the resources that are locally available. One of these resources is manpower, both skilled and unskilled.

Kenya as a developing country has undertaken interventions to reduce the rural urban dichotomy. To this effect, there have been several interventions that have been undertaken in the country to reduce the centrifugal effects of urbanization including the District Focus for Rural Development

(later on replaced by the Constituency Development Fund) in which the focus of development initiatives was the rural areas. The unit area of this strategy was the district made up of divisions subdivided into locations, sub-locations and finally villages in hierarchical order. Since this strategy emphasizes the bottom-up approach to development, interventions are supposed to be initiated at the location/village level and consolidated upwards to the district level. The process of development at the village level is led by community members made up of a myriad of people with the prominent participation of Village Elites.

This paper explores the participation of these Village Elites at various levels in terms of

social networks and the ensuing social capital, their role with regards to development support agencies and their contributions and effects in the key sub-sectors at the village level.

### **The Development Landscape in Kenya**

Before the colonial era the focus of movement and communication was quite limited. Most interaction occurred at the village level between family and community members. The main transport routes were footpaths and for those close to the lake there was some form of boat transport. Then came in the colonial population and the trend towards the transport, communication network and rural development as we know it was set into motion.

Lonsdale (1989: 6) observes that in the ten years between 1895 and 1905 Kenya was transformed from a myriad of footpaths into a colonial administration. This transformation was the work of force. This conquest of the peoples of Eastern Africa disrupted the trading networks that had linked the peoples of the region who had already reached some working equilibrium. Many of the economic activities that were now emerging created the need for new transport and communication networks to cater for these emerging interests.

The early European explorers into the interior of Africa, such as David Livingstone, believed that they could help wipe out the slave trade by encouraging commerce, thus providing an alternative to the income generated by the trade in human merchandise. This new wave of explorers tended to move inland unlike the earlier concentration at the coast by their forerunners. They established Caravan Routes that were to form the basis for many of the trunk roads in later years. Lonsdale points out that

“the British urgently needed to convert the external, costly and destructive force of the conquest into internal, negotiable and productive

power....But if Africans had to learn the European lesson of submission, the British had to learn the local African lesson, how to pacify their mastery. ‘Pacification’ rightly, is no longer used to describe the colonial conquest. What needed subjugation was not so much the disorder of Africa as the irruption of Europe. But Pacification is still a proper term to describe what the British had to do with their conquests rather than *with* it. They had used African power in order to undermine it profitably. They had to capitalise on the politics of conquest” (Lonsdale, 1989).

The East African region had to be opened up if there was to be any profit in maintaining the region as a British colony. However the British Foreign office did not begin serious planning for its future administration of East Africa until April 1894.

In 1895, the Ugandan Protectorate was formed. The rest of the land between the boundary of Uganda and the coast was to be administered from Zanzibar, as a protectorate. In 1887, with the active endorsement of the Foreign Office, that he had sought for so long, Sir William Mackinnon founded the British East Africa Association and it was a going concern the following year with the name having been changed to the Imperial British East Africa Company (IBEAC) (Miller 1971). The IBEAC established caravan stations along its trade routes into the interior. Mumias was its most important station in Uganda Protectorate. The eventual construction of the Sclater road in 1894, which traversed the highlands, enhanced trade and reduced the hazard of travel to the eastern parts of Uganda.

Miller *et al.*, (1994) aptly sums up the great fears that were driving the British at the time.

‘According to a logic that today seems fanciful, British policy focused on Uganda as a key to its strategic interests in Africa. The reasoning was



that unless Britain controlled Uganda, the headwaters of the Nile might be dammed by another European power. This would disrupt the river, bring Egyptian agriculture to its knee, cause peasant uprising in Egypt and the Anglo-Egyptian Sudan, threaten the Suez canal and prevent British entry to the Red Sea and beyond. India the Pearl of the Empire, and the Far East trade could become virtually inaccessible’.

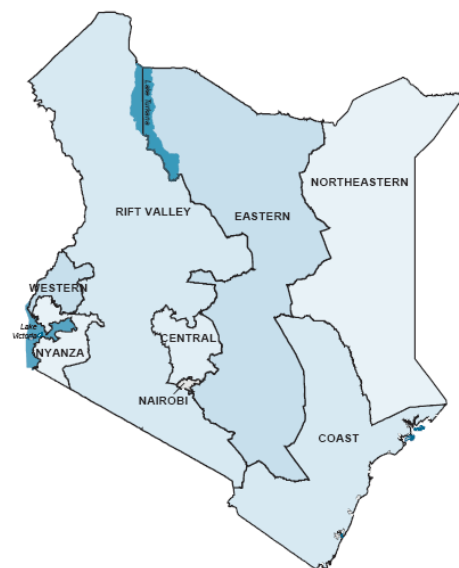
The IBEA had increased the geographical knowledge of East Africa, established ‘core’ caravan stations which were pivotal to settlement development. It thus secured for Britain the route from the coast to Uganda and continued to act as a buffer to foreign intervention, especially from Germany in the German East Africa, within the British sphere. The 27th August 1894 saw the formal proclamation of the protectorate and in the following year, on the 1st of July, the acting British Commissioner Colonel Henry White was declared the first Governor, based in Mombasa (Mungean, 1966).

By 1895 the IBEA had withdrawn from the area with the formation of the East African Protectorate on 1st July 1895 and so paved the way for Kenya to change from a chartered company to a British colony. In 1902, the western boundary of the Protectorate was altered to include the Eastern Province of Uganda.

It should be pointed out here that the 19th century caravan expeditions were the first stage in the opening up of East Africa to the products of Western industrial revolution and they also were the first step in European penetration of the area. As a consequence, the development of the railway line, began in 1896, tended to perpetuate the established spatial structure of the Kenyan landscape.

Development in colonial and post-colonial Kenya has seen the rise of a dichotomous community in which salaried employees spend their working life in the urban areas

and on retirement move to the rural areas. The emergent landscape creates a close link between the rural and urban landscapes. This rural-urban mosaic has also been closely linked with the emergence of a structure society in which there are community members who are perceived as elites. This is a result of the cultural nature of Kenyan communities in which the rural village provides an anchor for social security and ethnic continuity. On the other hand, we have a large number of teachers and religious leaders who are employed and are based in the rural areas, some of whom may have no cultural links with the area in which they are working since posting by the Teachers Service Commission is not based on regional origin.



*Figure 1. Kenya: Provincial Boundaries*

### **Village Elites**

The rural areas have tended to be sources of labor for the urban growth poles. In the rural areas there is a smaller population of resident skilled manpower as the educated youth tend to migrate to the urban areas in search of formal employment. The village elites therefore form a critical element of skilled labor in rural development.

It is difficult to quantify in detail the population of the Village Elites but they include

- Teachers in Village schools and village polytechnics
- GoK Staff (who take off during weekends). These include the Ministry of Water (provision of safe sources of water), Health (maintaining good standards of health through preventive and curative services), Agriculture and Livestock (ensuring food security in the community) and the Provincial Administration (Security for the local people).
- NGO staff who tend to focus on their organization goals.
- Retirees who perceive the rest as not capable and take over leadership.
- Consultants who have little interest or commitment to community needs.

**Table 1. Select Indicators of Categories of Village Elite**

Indicator	Total (n)	Approx Rural (n)	Estimated Rural Ratio
Primary School Teachers	170,059	136,047	1:200
Secondary School Teachers	43,016	30,111	1:1000
Medical personnel / 100,000 population	203		1:1200

Source: Kenya Economic Survey (2008)

The Village Elites, made up of retired employees from the formal sector and employees in the villages, make up the bulk of the rural elites and have significant control of how development interventions operate in the rural communities. Education level for almost all the Village Elites is secondary school education. A number of retirees and some NGO staff are graduates. Government graduate employees tend to gravitate to the local urban centers. The average income of Government employees including teachers ranges between \$200 to 300. The NGO staff

tends to double this. This is much higher than the over 50% of the rural population who live below poverty levels. Often the aspiration of these elites may not represent the bulk of the community, especially women given their higher economic status.

It is noteworthy that the participating government agencies in rural areas depend to a large extent on support from the external donor agencies to effectively deliver services to the community. The government extension officers often express expectations around transportation and allowances before they fully engage in the planning process. In several evaluations done in Western Kenya (Nyando, Migori, Rachuonyo, Homabay, Suba districts) of activities undertaken by a development agency indicates that at the expiry of the implementation phase, active engagement of government personnel gradually decreased, and this had considerable implications on the full sustainability of planned activities (CARE-Kenya, 2006).

The different categories of Village Elites have varying capacity to influence the development agenda at the community level. This is directly related to their level of participation, networking, access and control of resources. These are addressed in the consequent sections.

### **Social Capital, Resource Endowment and the Village Elites**

Whereas physical capital refers to physical objects and human capital refers to the properties of individuals, social capital refers to connections among individuals – social networks and the norms of reciprocity and trustworthiness that arise from them. In that sense, social capital is closely related to what some have called “civic virtue” (Putnam, 2000).

Putnam (2000) notes three aspects of social capital, namely that first, social capital allows citizens to resolve collective problems more easily by providing a mechanism in which the community members act as checks

on each other, second, social capital greases the wheels that allow communities to advance smoothly and third, way in which social capital improves a community's lot is by widening its awareness of the many ways in which their fates are linked. People who have active and trusting connections to others whether family members, friends, or fellow bowlers – develop or maintain character traits that are good for the rest of society.

Social capital attempts to link micro-social individual behaviour and macro-social structural factors. It attempts to set social relationships, social interactions and social networks within the context of wider structural factors (Morrow, 2002). The networks that are a part of the social capital of communities are seen as crucial in establishing relevant norms, values and roles, which respectively contribute to social stability, economic development and cohesion. Grootaert (2001) argues that associational life has a consumption value and is not sought merely for its economic benefits. This is related to the type of association: participating in church choir may have more consumption value than joining a farmers' cooperative. Village Elites have a vantage in enhancing this capital because of their linkages in prior or current employ, leverage that other community members might not have.

This is supported by Nyangena and Sterner (2008) in their study where they note that a peculiarity of social capital is that it cannot be directly measured and hence the use membership in associations as a proxy indicator.

Development agencies often insist on using local communities resource persons (CORPS) on aspects of the intervention strategies. The key criterion used in the selection process is often the level of education which tends to be a preserve of the Village Elites. The focus on education level is two pronged; one is the ability of the participants to appreciate the project cycle

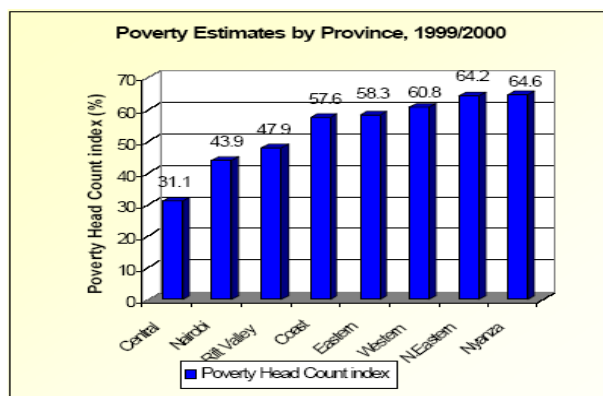
stages and secondly it enables the community members easily communicate and interact with these external agents who may not have capacity to communicate in the local language, and hence, bring in their personal bias in the development process. The other criteria on selection of CORPS are their acceptability by the community. A discussion with the Program Unit Manager for PLAN-K in Homabay and the M and E officer CARE in Kisumu indicates that the Village Elites influence to a great extent this selection process. These CORPS eventually end up in the management of the Community-Based Organizations supported by the external development agents and have a strong influence on the development interventions.

However, the social capital built by the poorer segments of the community acts as a counterbalance requiring these Village Elites who act as middlemen for development support to become answerable to the community members. Their continued stay at the social apex is thus made responsive to social norms.

There is a reasonable presumption (and evidence) that growth will reduce poverty. One general feature is that the poor have a lower opportunity cost of time and a lower stock of financial and physical capital than the rich. Since social interaction is time-intensive, and since social capital can often substitute private capital, the poor may choose to rely more upon social capital than the better off. However, there are sometimes countervailing considerations (Collier, 2001).

Aharonovitz and Nyaga (2008) note that responsibility and care (social capital) does impact on economic performance. Their study tend to indicate that the higher the value attributed to social capital, the higher the probability of lower economic performance and that this restricts a number of people to the traditional rural economy. Those who break away from these rural networks move to the modern industrial urban economy where social networks are

less critical. Their economic performance tends to be better. The 1997 WMS shows that the poor constitute 52.3% of Kenya's population. In Kenya, like other developing countries, lack of employment opportunities in rural areas has contributed to rural urban migration in search for better opportunities.



Poverty incidences varied widely from 31 per cent in Central Province (the least poor) to 65 per cent in Nyanza Province (the most poor). The poverty incidences are used for the allocation of Constituency Development Fund (CDF).

**Figure 2. Indicative Estimates of Poverty in Kenya**

Source: Kenya Facts and Figures, 2008

Data from the Government (Kenya, 2008) pointed out glaring regional disparities in terms of poverty. Poverty levels range between 30% and 65% across Kenya's eight provinces. Nyanza province was ranked as the poorest province (see Figure 2). Further studies in Kenya indicate that women are more vulnerable to poverty than men. 69% of the active female population work as subsistence farmers compared to 43% of men. Given that subsistence farmers are among the very poor, this relative dependence of women upon subsistence farming explains the extreme vulnerability of women. Men are still more likely to be in informal sector than women with participation rates of 55% and 45% respectively. The situation is grimmer in the formal sector where women participation is less than 30%. Female-headed households were poorer than male-headed with the former presenting a high poverty gap.

Poverty in women is linked to unequal access to and distribution of resources, lack of control over productive resources and

limited participation in political and economic institutions. As a coping mechanism, most women in rural areas have resorted to social capital. There are a number of formal and informal associations that allows for bonding, bridging and linking networks that allow these poor rural women survive the challenges of development at community level. The associations are formally registered with the Department of Social Services, which is critical in enabling the associations access credit from micro-finance institutions, Government Fund for women and Youth Development Fund, Constituency Development Fund, NGOs amongst other institutions. It is instructive that most of these associations, registered as a women group, have a token man who it is argued would enable the group access resources in cases where there are barriers that would be a barrier to women. These token men emerge as or are Village Elites who eventually also begin to influence the development agenda of the Women Group (Onyango, 2008).

The membership of a network will tend towards those with similar amounts of knowledge (though each with different knowledge). Those with a lot of knowledge will simply find it more advantageous to pool with others who also have a lot of knowledge. Treating this similar knowledge ability aspect as a constraint upon which networks an agent can join, the incentive to join an information network is greater the greater the amount of information in the network. Hence, those with little knowledge to share are confined to networking with others with little knowledge and so have less incentive to do so than those with large amounts of knowledge. Pooling is therefore regressive in two ways: the more knowledgeable will have larger networks, and the information gain from each contact in the network will be larger. In effect, pooling introduces an exponent term onto private knowledge. There is a tendency to the social exclusion of the poor built into private incentives to pool knowledge (Burger *et al.*, 1996). The Village Elite though being

part of the larger social networks form their own level networks that allows them to form bridging links with intervention agents allowing them to be in the forefront of access to resources. However, there are instances where these bridges are used as a stepping stone for the larger community's good allowing for resources to be channeled through the Village Elite associations, which eventually trickles to the community to finance various community development projects. Their knowledge levels give them access to resource potential links that would otherwise have been inaccessible to the less knowledgeable community members.

Village Elites through their bridging networks with external agents develop mechanisms of repeat transactions and reputation. Repeat transactions have the effect of social exclusion to new entrants and so tend to disadvantage the poor. Reputation gears up the gain from repeat transactions. Repeats produce a promise-trust bilateral relationship, and reputation enables those who are in a promise-trust relationship to access many other transactions (Biggs, 1996). In the long run, the Village Elites strengthen their bridging role in accessing resource for community development.

Collective action as a result of social capital is likely to be proportionately more beneficial to the poor since they are less able to invest in substitutes. In general, the poor have more to gain from norms and rules than higher income groups and so have more incentive to join association groups. For example, in micro-credit transactions, social sanction and collateral assets are alternative means of reassuring the lender. Wealthy persons do not need social sanction, whereas the poor do. Similarly, the economies of scale, which collective action facilitates, are more likely to be otherwise unreachable by the poor: hence the membership of Rotating Savings and Credit Associations (ROSCAs). Finally, if the main cost of membership is time, the poor have an advantage since they face lower costs. There is, however, an offsetting tendency. The creation of clubs

and authorities will generally require some leadership and leadership is much more likely to come from agents in higher income groups. They will be more respected, and so face lower costs of initiating collective action, and since initiative will tend to produce both leadership and income, the two will be correlated. If the clubs and authorities necessary for the creation of norms and rules are initiated predominantly by higher income groups, the Village Elites, they will both tend to address the problems faced by higher income groups and tend to attract membership from higher income groups (Collier, 2001; Meinzen-Dick *et al.*, 2002).

### **Development Support Agencies in Community Development: Role of the Village Elites**

The agencies that have been in the forefront of community development include Civil Society Organizations (CSO) and Government Ministries. CSOs have tended to focus on social parameters including education, health, water, sanitation and agriculture. The Government line ministries on the other hand works with donor partners in sector wide programs that are cross cutting. In all these endeavors the focus is on reducing poverty and enhancing income. Poverty is a major concern of governments all over the world, and countless poverty alleviation programs and campaigns have been developed over time and across regions. In Kenya, select indicator show the disadvantage of the rural communities and women (Table 2).

**Table 2. Select Poverty and Social indicators**

	Early 1980s	Early 1990s
Percentage of population below poverty line	48	46
Primary Enrollment Rate (Gross)	109	105
Male	114	106
Female	101	104

Primary Enrollment Rate (Net)		73
Bottom Decile		63
Top Decile		78
Infant Mortality rate	77	67
Rural		65
Urban		46
Mothers with Secondary education		35
Mothers with no education		66
Child Stunting Rate (under 5 years of age)	36	34
Rural		34
Urban		22
Mothers with Secondary education		21
Mothers with no education		37
<b>Note:</b> A percentage over 100 indicates that there are overaged children in primary school		

Source: World Bank, 1995

In Kenya, since independence, one of the principal goals of the government has been to reduce poverty. Currently, the government has established various plans to combat poverty that include the Interim Poverty Reduction Strategy Paper (2000-2003), the Economic Recovery Strategy for Wealth and Employment Creation (2003-2007) and the National Poverty Reduction Plan (1999-2015). The main theme across these plans is achieving a broad-based, sustainable improvement in the standard of living of Kenyans.

In a bid to further reduce and monitor poverty and development indicators, the Kenyan government endorsed the Millennium Declaration 2000. The Millennium Development Goals (MDGs) include halving extreme poverty and hunger, achieving free universal primary education

and promoting gender equality among others.

To reduce poverty, the poor are encouraged to be self-reliant. This has been done mainly by encouraging the poor to form groups that they can use to acquire credit (Adams *et al.*, 1984). In Kenya, group formation dates back to 1954 with the formation of the Ministry of Community Development. The Ministry's policy emphasized empowerment and self reliance mechanisms. This allowed for access to credit program by poor communities through groups. These groups included labor groups, ROSCAs and other voluntary associations.

The credit programs are a result of poor people's initiative and effort to harness pre-established social ties through collective action for the purposes of economic betterment. Access to credit is an indicator of well-being. Credit can be used to smooth over income fluctuations. In addition to credit, households are supported by several kinds of assets and resources. Households draw down on their savings, take out loans, borrow from others or sell their assets. In doing so, they limit the extent to which they have to restrict their consumption even when their income drops. Credit is perceived to assist the poor engage in income generating activities so as to generate incomes and assets to improve their welfare on a sustainable basis (CARE-Kenya, 2006).

The provision of micro-credit has been found to strengthen crisis-coping mechanisms, diversify income-earning sources and build assets.

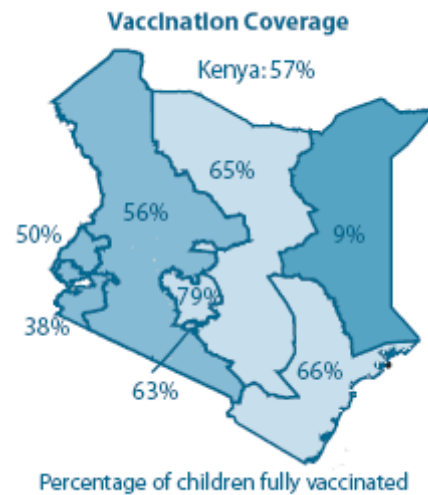
Credit creates opportunities for self-employment rather than waiting for employment to be created. It liberates the poor from the clutches of poverty. It brings the poor into the income stream. Given the access to credit under an appropriate institutional structure and arrangement, one can do whatever one does best and earn money for it. One can become the architect

of one's destiny and the agent of change not only for one's family but also for the society.

The central question is to establish why some households are able to acquire credit while others are cannot. It has been noted that credit institutions due to the nature of how they operate especially with their requirement for collateral will tend to prefer the Village Elite. They are better endowed in terms of resources such as land, housing and other assets that make it easy for them to be creditworthy. Many of them have also been able to leverage themselves to positions of leadership in the community associations that making them key in determining the development agenda of rural communities. The net result is that they continue to operate at the apex of the community social and economic structure.

An examination of the poverty estimates by province shows a distribution that also mirrors the level of intervention of the Village Elites. In areas where the poverty levels are lower the Village Elites have a comparatively higher income. The net effect is that the quality and quantity of development interventions have also tended to take this pattern. For example a look at the vaccination coverage shows that vaccination coverage increases with mother's education and wealth. There are also large variations by province. In Central Province, for example, 79% of children are fully vaccinated, and only 2% have received no vaccinations at all. In contrast, only 9% of children in North Eastern Province have been fully vaccinated, and 46 percent have not received a single vaccination (Figure 3). If community health interventions were to take place, the little resources would be used for immunization in North Eastern while in Central province they would be moving to the next level of health care (Kenya, 2005).

The Village Elites as drivers of community development would thus be grappling with different levels of development based on the overall wealth status of the local community.



**Figure 3. Vaccinations: Proxy indicator of mortality per Province**

Source: Kenya Facts and Figures, 2008.

### **Need for External support in rural development**

Scholars and developments practitioners have documented widely on the processes of development taking place, particularly in the rural areas, in terms of the impacts that these have had on the livelihoods of the intended beneficiaries, both positively and negatively. The underlying assumption of action planning in community projects is to address the effects of the pervasive nature of poverty. However, the complexity of the problem has never been clear.

Chambers (1983) observes that the past quarter of the century (1900s) was a period of unprecedented change and progress in the developing world. And yet despite this impressive record, some 800 million individuals continue to be trapped in what he terms as absolute poverty: a condition of life so characterized by malnutrition, illiteracy, diseases, squalid surroundings, high infant mortality, and low life expectancy as to be beneath any reasonable definition of human decency.

The latter day ease with which officials, businessmen and international experts can speed along highways, has the effect of almost entirely divorcing the rural sector from its urban counterpart; no longer must

“dry season earth roads be negotiated and preparations made for many night stops in villages. “...it is now possible to travel 100Km or more through the countryside (in limousine comfort) during the morning and get back to the city in time for lunch having observed nothing of the rural condition.....” The net effect is that the rural poverty remains largely unperceived right from the onset of the first contact made with the local communities by the external support agents. In the long run, it is unlikely that these agents would have a clear perception of the nature of complexity that is obtained in the local set up to be able to plan sensitively with these in mind. More often than not, we thus end up with externally-conceived priorities perpetuated through their local agents, the Village Elite, against the felt needs of local people.

According to Chambers (1983), many biases impede outsider's contact with rural poverty in general, and with the deepest poverty in particular. These apply not only to rural development tourists but also to rural researchers and local level staff who live and work in rural areas. These sets of biases include spatial, project, dry season, person, diplomatic and professional biases.

For Covey (1999) the more genuine the involvement the more sincere and sustained the participation in analysing and solving problems, the greater the release of everyone's creativity and of their commitment to what they create. There is need for a simple axis that distinguishes depth and breadth of participation. Deep participatory planning processes engage participants in all stages of a given activity, from identification to decision making. Yet they can remain narrow if only a handful of people, or particular interest groups are involved. Equally a wide range of people might be involved, but if they are only informed or consulted, their participation would remain shallow. This usefully highlights the interception between inclusion/exclusion and degrees of involvement. This then is the tragedy of the

Village Elites hijacking the development agenda.

Dillon and Steifel (1987) observed that for people in the community who have always had the dominant voice in local affairs, it can be seriously threatening to have new concerns, and taking actions based on their own priorities.

It can be equally difficult for the poor to overcome their lack of confidence and their scepticism about the potential for change. In most places, the problem is not that the poor are lazy; they are busy trying to survive and may never before have succeeded in asserting themselves. They have felt themselves to be at the mercy of forces beyond their control. Furthermore, in addition to shedding these very real spiritual and psychological burdens, the poor must overcome other concrete obstacles that result from generations of deprivation-lack of information, lack of resources and, perhaps most important, lack of experience in finding companions with whom to forge a common cause, discuss, consider alternatives, and take actions.

These very characteristics of participatory development which make it important in the community- its ongoing and dynamic nature, its local management, its concern with issues of power and resources and their wider distribution, it's potential for reducing inequities in the community- all make it a complex and delicate process to comprehend, and to make it work.

Once participatory processes are established, they take on dynamism of their own and are not susceptible to simple control, and particularly not from the outside. The unworkable, unpredictable and uncontrollable are threatening to many people and systems. Official and unofficial structures, or groups and institutions, outside a community in which poor people are organizing and taking action may tend to put obstacles in the way of the process rather than support it.



For outsiders who would like to help the process, the questions are always: Who? How, and how much? When and What? (Srinivasan,1992) for a key element in people-centred development is the search for self-reliance and control over the local environment-social, political, economic-and therefore, support must be appropriate in nature, size and timing. It must be in proportion to local resources, needs and capacities. It must not overwhelm the sense of local accomplishment or introduce unnecessary complications. Faced with this somewhat unpredictable, very human and sometimes volatile mix, many outsiders-whether official or unofficial-may decide 'not to get involved' and so resources of information, materials, and training are withheld.

Those who work with rural communities in Kenya on continuing basis find that certain issues arise again and again within field programmes. There is, for example, the "big man" syndrome: the necessity when dealing with villagers of securing the backing of influential Village Elites. Sometimes factionalism - an internal polarization of the community into rival social groups - must be allowed for and even counteracted. On other occasions, service staff encounter "adopted" or "pet" villages-communities which receive help not because of their needs but because they are known and liked by district officials (Government Local Elites), or perhaps a Minister in the national government. In many rural areas, people have become accustomed to waiting passively for external interventions as an answer to all problems (Moris and Copestake, 1993).

### **Controlling development intervention**

Development takes place constantly. People make conscious choices to change things for the better all the time.

Broadly speaking, there are two ways of intervening in the development process;

- Through a longer-term fieldwork approach which consciously supports people in identifying these constraints

and working through them at their own pace - a process approach.

- Through designing and implementing a project, which has a defined lifespan. The project when completed should leave behind the resources, capabilities and tangible changes with which people can willingly continue to work - a project approach.

*Production centered* development has been supported by its own organizational models and decision making methodologies. Generally it has favored command system forms of organization, which respond to formal central plans based on the decision rules and methodologies of rational decision analysis.

Dealing with defined problems in stable environments, such systems can be relatively efficient. But they tend to be unresponsive to local variety and to make little use of the creative energies of most of their members.

*People centered* development favors the organizational models of self-organizing systems, which operate in a more organic fashion. The structures and information flows of self-organizing systems are geared to the goal-setting and problems-solving processes of their various sub-systems so that innovative and adaptive action that is, learning, occurs continuously throughout the total system (Korten, 1984).

Kenya became independent in the decade of the 'Development Administration' movement. Therefore her first concern in the field of administrative change was the creation of development institutions. The approach was two pronged; as central level institutions were being put in place (e.g. the establishment and expansion of the Ministry of Planning and Development) similar structures were also being introduced at every administrative level in the field.

The first structures to be introduced at every administrative level in the field were the development committees. One set was

advisory; the other one was quasi-executive in the sense that they were supposed to plan for and coordinate all development activities in their areas of jurisdiction. These development and advisory committees had been established throughout the country by 1970 and charged with the coordination and stimulation of development at the local level by involving in the planning process not only the government officials but also the people through their representatives, and also to be major instruments in plan implementation (Kenya: 1969, 1974).

Contrary to the assumptions of many watchers of the Kenyan administrative scene, these committees were never intended to be used for purposes of decentralization. The Ministry of Planning that had created them wished to see them play the agency's role on its behalf and in that sense they were in many respects part of the ministry.

Indeed, the Ministry itself was barely a year old when the idea of establishing these committees first came up in the Sessional Paper No.10 of 1965 (Kenya, 1965). Therefore, the creation of the committees could not be seen as an exercise in power delegation. More importantly, the committees lacked executive authority on matters of development just as the Ministry of Planning also did at the centre. They were, therefore, weak in their relationship with operating ministries.

At the same time that the idea of the development committees was being popularized, a group of expatriate advisors, donors and academicians were busy urging the Ministry to introduce a special experimental programme in rural development (Oyugi, 1981). Accepted in principle in 1966, it became known by the time of its launching in July 1970 as the Special Rural Development Programme (SRDP). Initially it covered six administrative divisions, and plans were on hand to extend it to other parts of the country, but it wound up in 1976 before that could be done. While it lasted, the

programme attempted to experiment with various forms of de-concentration, which were felt to be critical to the success of rural development (Chambers, 1974).

What is today referred to in Kenya as district planning originated from lessons from the SRDP. District Focus for Rural Development (DFRD) is the main planning system that is used in all the districts in Kenya. Under the system, District Development Committee (DDC) is the top most platforms where the planning decisions in the districts are taken. The platform under the chairmanship of the District Commissioner brings together all key stakeholders in development in the district. Politicians, District Executives both from Government Offices and NGOs and private organizations are invited to this platform. District Development Office (DDO) is the secretary to this committee.

The planning process for District Focus for Rural Development is supposed to start in the location where Location Development Committee (LDC) is set up. In reality, only project ideas are presented and prioritized for forwarding to Sub-DC at the division. The latter also take a similar action with LDC except the ideas are compiled and presented to District Executive Committee (DEC) and later DDC. In almost all these committees the membership is composed of Village Elites who either are local civil servants, CSOs representatives or appointees of the local Members of Parliament

Besides DFRD, there is also the planning by the local government in the districts. It is important to note that the planning process by local authorities is legitimized by the constitution particularly through Local Government Act. This is different from DFRD, which is only legitimized by policy.

Further, planning at local authority level is undertaken through the process of the Local Authority Service Delivery Action Plan (LASDAP). Ideally, the process involves various stakeholders, representing diverse

interests at Municipality or County council level converging to plan for various courses of action on issues affecting the authority; area of jurisdiction. Inherent in the strategy in the involvement of grassroots people in the decision making on issues affecting them. Implementation is facilitated through the Local Authority Transfer Fund (LATF) which had a budget of \$103m in the last financial year, from the parent Local Government Ministry. Only 40% of this fund goes for service delivery resulting in negligible outcomes. Local participation takes place at ward level in terms of consultation but planning and execution is centrally executed by councillors and chief officers, who prioritize needs based on political and sectarian interests. The plan thus hardly involves the views of the majority community members it is likely to affect. However the Village Elite through their social network with Local Government officials are able to influence interventions in their favour at this level. They weave their way into the ward committees where their views are sought to be consolidated into the LSDAP.

At the next level, the Constituency Development Fund (CDF) is a parliamentary provision that allocates up to 2.5% of the overall national budget in Kenya for project development at the Constituency level. Prioritization and implementation is done by Constituency Development Committees, which are also responsible for planning for what needs to be done. The CDF fund is geared for education, health and road infrastructure development. A small proportion (up to 20%) is used to fund orphans and vulnerable children through a Bursary Fund.

A critical assessment of the performance of the Fund has showed sporadic successes particularly with respect to technical implementation e.g. construction of schools, health facilities and water sources. However, these projects are not specifically targeted to any vulnerable group and thus may not have deliberate targeting of poverty

alleviation. Questions have also been raised with regard to composition of the committees, capacities and skills to undertake complex tasks, favoritism and political patronage (KIPRA, 2008). As it were, gaps still remain with regard to social inclusion of marginal groups and clans, giving those overlooked no incentive to cooperate. Another key bottle neck identified is the occasional overwhelming influence of the local Members of Parliament (MP) in the determination of who comprises the Committees, with accusations of nepotism and biased selection of cronies who are mostly picked from the Village Elites who have access to the MP.

Ogosia and Namunane (2008) writing for Daily Nation report that a Government report on ranking parliamentary constituencies on poverty index was withheld after some MPs complained that their areas were not projected as poor enough. Some constituencies that previously were ranked as the poorest in the country have suddenly shot up the table to upstage the traditionally well-off areas, prompting the MPs to complain that the report was rigged. The fear that their constituencies will get less Constituency Development Fund (CDF) money if found to have fewer people living in poverty.

The report recommends that the formula used for allocating CDF be reviewed with a view to getting rid of the discrepancies that have emerged since the fund was established in 2003. A total of KSh. 34.2 billion was allocated to the fund between 2003 and 2007. Instead of giving all constituencies 75% of the allocations equally and the remainder on the poverty index, the report wants the allocations to reflect population.

'In the five years of CDF implementation, some sparsely populated constituencies received transfers equivalent to almost KSh.18, 000 per person vis-à-vis under KSh.900 in the heavily inhabited constituencies,' it states.

The report shows that Bondo and Rarieda constituencies are richer than Othaya constituency (which was President Kibaki's constituency); while Nyatike, a semi-arid area is reported to have overtaken agriculturally-rich constituencies such as Nakuru Town, Molo, West Mugirango and Kitutu Masaba. The new report also shows that some constituencies previously ranked well-off are now among the poorest. They include Saboti, Kwanza, Mt. Elgon, Mumias, Lurambi, Lugari, Cherangany, North Mugirango, Sotik, and most of the Central Province constituencies like Juja, Mathioya, Kiharu and Mukurwe-ini.

The establishment of the Women Enterprise Fund, and the Youth Enterprise Fund, each with about \$22M of funds to be allocated to Women and Youth Groups in sums not exceeding \$650 per group in the rural areas. The social networks that have been built in the rural areas coupled with higher education levels of the Village Elites puts them at the vanguard of accessing these resources.

Development support agencies who have undertaken interventions in Kenya have wondered why they are having lower impact than they anticipate in their project designs (RELMA/SIDA, 2004; CARE-Kenya, 2006; CCF, 2007).

We begin to see the challenges that development agencies need to address with regards to village elites and community development to ensure that the members of the community contribute effectively to rural development and enhance impact levels.

Effective actualization of planned activities within communities is based on convergence of three key factors, viz-a-viz competent application of participatory approaches and methods as interactive as learning environment and, institutional support and context. In the process, the Village Elites play a key role in being at the forefront of mobilizing participants for planning processes and linking with institutions where

most of them are working or had worked; the social networks being a strong factor in ensuring control.

### **The Myth of Participation**

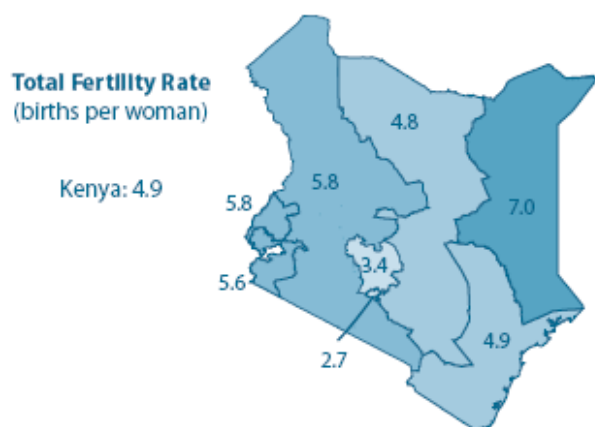
The thrust of rural development has been to enhance community participation in such initiatives. A look at examples of rural development practices in the country shows some of the challenges that the poor have to address if they are to effectively participate in development.

KIPRA (2008) undertook a review of the CDF and its findings indicate that there is little community participation in this fund. Respondents were asked to rate their participation in relation to different kinds of involvement in the management of decentralised funds. The survey found that, generally, participation is very low in the various funds, particularly in decision-making processes.

Respondents indicated that while 32.8% of them were involved to the extent of receiving information or listening at '*barazas*', less than 10% attended meetings to discuss specific issues and less than 5% felt that they were involved in decision-making. Over 90% of respondents indicated that they were not involved in the setting of the development agendas for their areas. This underlines the appropriateness of efforts aimed at increasing public participation (KIPRA, 2009).

Ochieng (2006) in a study in Kisumu West district notes the challenges of health services for the rural poor. Socio-economic status (interpreted here as education level) dictated choice of health facilities and perceived view on quality of health care. Majority of clients who visit Government health centers were of low social economic status. The general condition of Government health facilities is wanting in a number of areas and is perceived as inadequate. Areas with poor health facilities obviously tend to also have higher mortality rates. The logical response to higher mortality for the rural poor is to have more children in the belief that there is

a higher chance of some of the children reaching adulthood (see Fig 4). The local members of parliament have been at the forefront of addressing these issues with almost all constituencies using the CDF funds to put up health facilities for the rural poor. Members of the CDF committees who are made up of Village Elites determine the design, location and operation of these facilities.



**Figure 4. Spatial Distribution of Fertility Rate per Province**

Source: Kenya Facts and Figures, 2008.

Studies on fisher-folk along Lake Victoria (ECOVIC, 2001) indicate that the fishermen had lower income than either the retailers or the wholesalers despite the fact that they are the suppliers. On the other hand, the wholesalers handled larger quantities and sold more than either the fishermen or the retailers because they procured from both at the same time. This left the retailers and the fishermen to dispose of their volume at low prices.

The implication of the level of education on the livelihood of the fisherfolk is that, the higher the level of education attained, the greater the level of savings and investment. In addition, better education attracts higher income, due to their ability to bargain and convince the buyers that the fish is of good quality. In essence, the Village Elite of the fisherfolk community have had two roles,

first they are amongst the people who act as middlemen and thus control the fish prices and the market linkages. On the other hand they have been initiators of groups and association which have enabled the fisherfolk to take control of their produce. This has been facilitated through Beach Management Units (BMU) found around all beaches on Lake Victoria. Support agencies are thus obligated to use the BMU as community entry points in the fishing sector.

An evaluation of SIDA/RELMA intervention in Nyando, Western Kenya (Oyoo, 2008) highlights the challenges that accrue in rural development when the aspirations of the community and the role of the elites are incongruent.

The study notes that the emergence of false expectations from the Village Elites from a dominant clan who were not party to the action planning e.g. demands for a health facility (hospital) even when this option had not been suggested during the community action planning session.

Considering that they exercised populist influence over a large area, it becomes difficult for the project management to steer the process towards the planned direction, as emotional sentiments based on clan interests became dominant. Additionally, the emergence of such interest exacerbated inter-clan differences and conflicts, leading to exclusion of the minority clan in crucial decision making. This, no doubt, affects effective implementation.

In terms of positioning for decision making about the project direction, women ended up with nominal roles and thus even their practical and strategic interests and needs as articulated in the action plans lacked a strong voice when it comes to the operationalization or activation of the plans.

Overall, this had the effect of keeping women out of mainstream decision making despite the PRA study having identified most issues affecting local people in the area,

being closely related to women needs and that they bear the greatest brunt of the problems experienced, making their poverty more profound. Structurally, the marginalization of women from governance positions, in favor of traditional norms which favor male domination, negated the very objective of reducing poverty.

On the other hand, the PRA methodology does not on its own explore root causes of poverty, powerless or conflict. This, coupled with apparent lack of flexibility and responsiveness to context by facilitators rooted in patterns of practice with which they were more familiar (traditional top down modes of instruction), means that understanding more analytically the reasons for apathy in engaging in development activities in the community, for the most part was lacking or inadequate.

Mobilization for implementation, it has been observed, and also noted from interviews and discussions with various stakeholders, become quite cumbersome and time consuming. Those targeted by the intervention, namely the poorest and marginalized, remained elusive or in the extreme, reluctant to participate either for fear of social or economic loss, considering the implications of cost sharing which is an integral aspect of the donor strategies in Kenya. This provides an avenue for the Village Elite he hijack such processes and thus most project evaluations show lower impact amongst the target groups yet all the planned activities may have been undertaken.

To showcase the control of Village initiatives by Elites a case study of Kusa Community Development project gives a clear picture. The Regional Land Management Unit of SIDA (RELMA) implemented a project in five villages in Kusa area in Nyando District of western Kenya. The project from initiation was viewed as just another NGO project (Wagner *et al.*, 2005). However the project initiators met a few Village leaders to help mobilize the community for the pilot

project. This initial team facilitated the identification of sites for the placement of Ferrocement Water tanks to harvest rainwater. Most of the team members were people who had been participating in the CARE project which came to an end as RELMA moved in (ibid) This project was Valid for those better off village members with Iron Sheet roofs. These initial beneficiaries appreciated the intervention better and thus during the mobilization they put themselves in vantage positions to take over the project leadership. It thus the same fifteen of so people, three women and twelve men have been rotating the leadership amongst them. This included the Village committee, Kusa Community Development Society and they eventually were also the key leaders in the World Kenya projects. Two of the initial leaders have since died but the general structure of the control system remains.

Wagner *et al.*, (2005) note that in most rural development projects, participation mainly (PRA) is translated into operational frameworks as a primarily technical corrective - focusing on instruments, guidelines and techniques, thus rendering "technical" what are essentially "political" problems in effect sidestepping the relations of power that keep people marginalized and poor.

The trend was observable in communities where PRA is used as a community entry approach the implementing agent prescribes operational frameworks over understanding the deeper underlying causes of poverty. For instance, the rural poor are routinely considered as an aggregated mass (community) - a definition which creates the first distortion on how the problem is perceived.

The understanding of participation in this sense fails to acknowledge people's significant differences in occupation, location, land tenure status, sex or religion- all which are related in different ways to their livelihood condition and hence their

capacity to participate at different levels. This oversight has provided an opportunity which naturally has been exploited by the Village Elites.

### Conclusion

We do note that looking at community development in Kenya, the Village Elites are at the forefront in various ways. They are involved in key decision making positions which may be adduced to the fact that they are better educated, have more resources and have strong networks that put them in vantage points.

It is important to remember that the Village Elites while living within the communities also have a foot in the world outside their community environment. They have strong social capital that includes bridging networks that can be used to enhance community development. We thus note that it is crucial to appreciate that Village Elites need to be directly targeted for community development instead of being subsumed in the aggregated mass (community). They have strengths which can be used to effectively enhance the potential of development impact in rural communities.

### References

**Aharonovitz, B. G. D. and Nyagac E. K.** (2008). Values and Economic Performance: Theory and some Evidence from Kenya.

**Biggs, T.** (1996). 'Structural Aspects of Manufacturing in Sub-Saharan Africa: Findings from a Seven Country Enterprise Survey'.

**Burger, K., Collier, P., and Gunning, J.W.** (1996). 'Social Learning: an Application to Kenyan Agriculture', mimeo, Free University, Amsterdam.

**Collier, P.** (2001). Local Level Institutions Working Paper No. 4 SOCIAL CAPITAL AND POVERTY The World Bank Social Development Family Environmentally and Socially Sustainable Development Network.

**Collier, P. and Gunning, J. W.** (1999). 'Explaining African Economic Performance', *Journal of Economic Literature*.

**CARE Kenya.** (2006). Mid Term Evaluation of Dak Achana – Sustainable Livelihood Security Program for Vulnerable Households in Nyanza Province Care International in Kenya.

**CCF.** (2007). End of Project Evaluation Youth Outreach HIV/AIDS ANGOF Project, Kasarani Nairobi. Christian Children Fund.

**Chambers, R.** (1983). *Rural Development- Putting the Last First* Longman Scientific and Technical Group.

**Chambers, R.** (1974). *Managing Rural Development: Ideas and Experience from East Africa*, Scandinavian Institute of African Studies, Uppsala.

**Covey, S.** (2000). *The Seven Habits of Highly Effective People*, Simon and Schuster. The Bath Press.

**Dilley, M. R.** (1965). British policy in Kenya colony. Francass, London. p15.

**Dillon, H. and Steifel, J.** (1987). *Implementing programmes of Human development* University Press of America.

**ECOVIC.** (2001). Interim Review of the Pilot Partnership between ECOVIC and Forum Syd. Forum Syd, Mwanza.

**Grootaert, C.** (2001). Local Level Institutions Working Paper No. 10. Does Social Capital Help The Poor? A Synthesis Of Findings From The Local Level Institutions Studies In Bolivia, Burkina Faso And Indonesia The World Bank Social Development Family Environmentally And Socially Sustainable Development Network.

**Kenya, Republic of.** (2005): Kenya Demographic Household Survey 2003. Government Printer, Nairobi.

**Kenya, Republic of.** (1974). National Development Plan 1974-1978, Government printer, Nairobi.

**Kenya, Republic of.** (1969). Kisumu District Development plan 1969-1973, Government printer, Nairobi.

**Kenya, Republic of.** (2008). Economic Survey, Government printer, Nairobi.

- Kenya, Republic of.** (1984). South Kano Irrigation Program: Project Proposal, Technical note 28, Min of Agriculture: Land resource development division, Irrigation & drainage branch, PIU, Nyanza Province.
- Kenya Republic of.** (2008). *Facts and Figures* Ministry of Planning, Nairobi, Kenya.
- Kenya, Republic of.** (1965). *Sessional Paper No. 10 of 1965*: Government Printer, Nairobi.
- KIPRA** (2009). Constituency Development Fund. [www.kippra.org/Constituency.asp](http://www.kippra.org/Constituency.asp).
- Lonsdale, J.** (1989). 'The conquest of state 1895-1904' In: Ochieng W. R. (edit) A modern history of Kenya 1895-1980. Evans Brothers, London. 6.
- Meinzen-Dick, R., Knox, A., Place, F. and Swallow, B.** (2002). *Innovation in Natural Resource Management: The Role of Property Rights and Collective Action in Developing Countries*. Washington, D.C.: IFPRI.
- Miller, C.** (1971). *The lunatic express: an entertainment in imperialism*. Macmillan London. 172
- Miller, N. and Yeager, R.** (1994). *Kenya: The quest for prosperity*. Westview press, Boulder (Colorado).
- Mungean, G. H.** (1966). *British rule in Kenya: 1895-1912*. Clarendon Press, Oxford. 8-13.
- Nyangena, W. and Steiner, T.** (2008). Social capital and institutions in rural Kenya. Environment for Development.
- Ogosia, K. and Namunane, B.** (2008). Constituencies Ranked By Poverty Levels. Daily Nation 28 August 2008.
- Ochieng, S. J.** (2008). Assessment of Monitoring and Evaluation Systems of Constituency Development Fund Project in Kisumu District, Kenya. Unpublished Thesis. Maseno.
- Putnam, R.** (2000). *Bowling Alone: The collapse and revival of American community*, New York: Simon and Schuster: 288-290.
- RELMA/SIDA** (2004). Kusa Community Development Project. End of Project Evaluation. Regional Land Management Agency/Swedish International Development Agency. Nairobi.
- Wagner, B., Goldsmith, P. and Okado, M.** (2005). The Kusa Experience; Community Development in Western Kenya. World Agroforestry Centre Nairobi.
- Woolcock, M.** (2001). 'The place of social capital in understanding social and economic outcomes', Canadian Journal of Policy Research Volume 2.
- World Bank.** (1995). *Kenya Poverty Assessment*. Report No. 13152-KE. Washington, D.C.: World Bank Population and Human Resources Division, Eastern Africa Department, Africa Region.



# **Flood Management Capacity in the Lake Victoria Basin, Kenya: A Case Study of the Migori-Gucha River Basin**

By  
**Abuya, J<sup>1</sup>**

<sup>1</sup>*School of Planning and Architecture, Maseno University, Kenya*  
Corresponding author: [jabuya2000@yahoo.com](mailto:jabuya2000@yahoo.com)

---

## **Abstract**

Rainfall is the most important climatic variable in Kenya that supports most livelihoods, including rain-fed agriculture. However torrential rainfall experienced during the wet months of March-April-May and October-November-December often translates into high stream/river flow (runoff) in permanent and intermittent streams/ivers across the country, resulting in seasonal floods. The effects of such floods is often devastating, with significant socio-economic losses. This study sought to investigate the current situation and problems on flood management capacity of relevant institutions and affected communities in the Migori-Gucha River Basin as well as identifying and analyzing future thematic areas for improvement of flood management. The study used social surveys and spatial analysis for data collection. The findings reveal that current flood risk management strategies-protection plans, early warning systems, flood disaster response and recovery strategies are far much inadequate. It is recommended that an Integrated Flood Management Approach be implemented with the community members taking a leading role in watershed management as well as flood risk management while the government should increase its investments in structural interventions.

**Key words:** Disasters, floods, Vulnerability, structural interventions, capacity building, climate change.

---

## **Introduction**

In many parts of the world, flood disasters are becoming increasingly frequent and devastating in their impacts. Other than infrastructure destroyed, human lives have been lost and livelihoods disrupted and this tend to fall most heavily on the poor in developing countries where coping mechanisms are severely constrained by high levels of poverty and limited state capacity to respond or contain. The phenomenon of climate change and variability also threatens to heighten these impacts in many areas, both by changing the frequency and/or

intensity of extreme events and by bringing changes in mean weather conditions that may alter the underlying vulnerability of populations to hazards.

Kenya has been visited by major flood disasters in the past. The floods have led to losses in human lives, livelihoods, destruction of national infrastructure, as well as of vital environmental resources. The economic costs associated with the losses occasioned by past floods is huge, and has been rising in the recent past owing to the increase in the intensity and frequency of

flood events in several parts of the country. In the last couple of decades, Kenya has experienced serious incidents of flooding disasters in different regions of the country, causing major disruptions in daily activities, destroying property and resulting in loss of human lives (GoK, 2009; MWI, 2009).

Although floods largely result from natural causes, they are increasingly being caused by human activities that lead to the manipulation of watersheds, drainage basins and flood plains (MWI, 2009). For example, recent floods have occurred in the river basins even with normal of excess surface runoff occasioned by deforestation, land degradation and poor land use planning upstream. A recent Government Report (MWI, 2009) reckons that in Kenya, the flooding problem has been a perennial occurrence, each time taking back years of development investments, as a result costing the government and communities millions of shillings in reconstruction and recovery.

Based on climate change projections for the region, the destructive consequences of floods in Kenya are likely to increase in the near future, if appropriate measures are not put in place to handle the impact of floods in the country. Indeed, floods are the leading hydro-meteorological disaster in the larger East Africa. In Kenya specifically, floods are emerging as the most prevalent climatic disaster (MWI, 2009). Perennial floods affect low-lying regions of the country such as river valleys, swampy areas, lakeshores and the coastal strip that are unevenly distributed in the country's five drainage basins. Geographically, the western, northern, eastern, central and south-eastern parts of the country are quite susceptible to seasonal floods in the wet seasons of March-April-May (MAM) and October-November-December (OND). The Lake Victoria Basin in western Kenya is the most flood-prone region in the country (GoK, 2009). The Arid and Semi Arid Lands (ASALs) that comprise of 80% of total landmass in Kenya are also prone to flash floods. This is despite the fact that ASAL districts such as Garissa and

Tana River record an average rainfall of only 300-500 mm annually, compared to the rainfall received in the Western and Central Highlands, at between 1600-2000 mm (Ocholla, 2010; Mutimba *et al.*, 2010).

The prevalence rate of floods in Kenya stands at 27% and accounts for 5% of the population affected by disasters. Floods-related fatalities constitute a whopping 60% of disaster victims in the country (UNEP, 2009). In particular, flood occurrence trends in western Kenya (Nyando and Kano flood plains) is increasingly becoming a major concern for the region's socio-economic development, owing to the substantial economic and financial losses incurred in responding to the frequent flood disasters which visit those parts of the country.

Ordinarily, floods following torrential rainfall affect Kenya. These force thousands of people living in the lowlands to move to higher grounds. As already pointed out, the people affected are mostly in Western and Nyanza provinces, and in Tana River District. However, slum dwellers in towns like Nairobi and Kisumu who have erected informal structures near rivers are not spared either. In Nyanza and Western provinces, rivers Nyando and Nzoia, respectively, are notorious for bursting their banks during the rainy seasons, destroying property and displacing thousands every so often. Kenya's record of flood disasters indicates that the worst flood events recorded so far were in 1961-62 and 1997-98, the latter one being the most intense, most widespread and the most severe. During this season the flooding was associated with the El Niño weather phenomenon.

This study sought to investigate the current situation and problems on flood management capacity of relevant institutions and affected communities in the study area. It also sought to identify and analyze, based on the study findings, future thematic areas for improvement of flood management.



**Figure 1. Map of the study site**

## Methodology

### Study Area: The Gucha-Migori River Basin

The Gucha-Migori river basin falls within both the middle and lower catchments of the Lake Victoria South Catchment Area (LVSCA). The river system, estimated to be 149 km in length, originates from the Mau complex water tower (Figure 1). It has a catchment area of 6,919 km<sup>2</sup>, with an annual discharge of 58m<sup>3</sup> /s. The river drains into Lake Victoria, contributing some 7.5% of the annual runoff. Nationally, the river system supports major farming activities as well as being an important source of water for domestic and industrial uses. It also hosts a national hydroelectric power plant at Gogo Dam. The river basin has potential for irrigation, multipurpose dams as well as economic use of floodwater and increase of the capacity for carbon sequestration.

### Research Design

This study was conducted within the Gucha-Migori river basin. The study employed

descriptive and diagnostic analyses in its approach. Assessments at the catchment level were done on the capacity of communities as well as local Water Resource Users Associations (WRUA) to prevent and or cope with floods within their respective localities. At community level, primary data was collected by administering structured questionnaires through interviews. This was also accompanied by selective focus group discussions. At WRUA level, a checklist of open-ended discussion points and questions was administered to WRUA officials and members. Two WRUAs namely; Lower Gucha-Migori WRUA and Korondo Nyasare WRUA were interviewed. Key informant interviews were administered to officers of the Provincial administration who included a District Officer, Chiefs and Assistant Chiefs, Officers at the Ministry of Water, Local Authority Officials like area councilors and chief officers within the basin were also interviewed.

The study employed probabilistic sampling techniques in which a combination of cluster/area sampling and multi-stage random sampling methods was used. A total of 180 households were interviewed at the

community level (Table 1). Distributed as follows:

**Table 1. Distributions of households in the study site**

Nyatike District		No.	of
Clusters		respondents	
Gucha-Migori	Kabuto	18	
	Nyora	18	
	Kimai Swamp	18	
	Sango	18	
	Gogo Dam	18	
Gucha District		No.	of
Clusters		respondents	
Tendere		15	
Igare		15	
Nyambunde		15	
Rigoma		15	
Booch		15	
Kegati		15	
<b>Total</b>		<b>180</b>	

Data analysis was done in different phases. The structured questionnaires administered to community members were designed to generate statistical outputs. As such they were analyzed using descriptive statistics such as means, percentages and cross tabulations among others. Data from focus group discussions, Key Informant Interviews and the researcher’s own observations were collated and synthesized through a qualitative analysis to generate wholesome, objective and deeper understanding of the subject under study. Narratives, graphs, pictures, maps have been used to present the findings.

## Results and Discussions

### Respondents’ demographic profiles

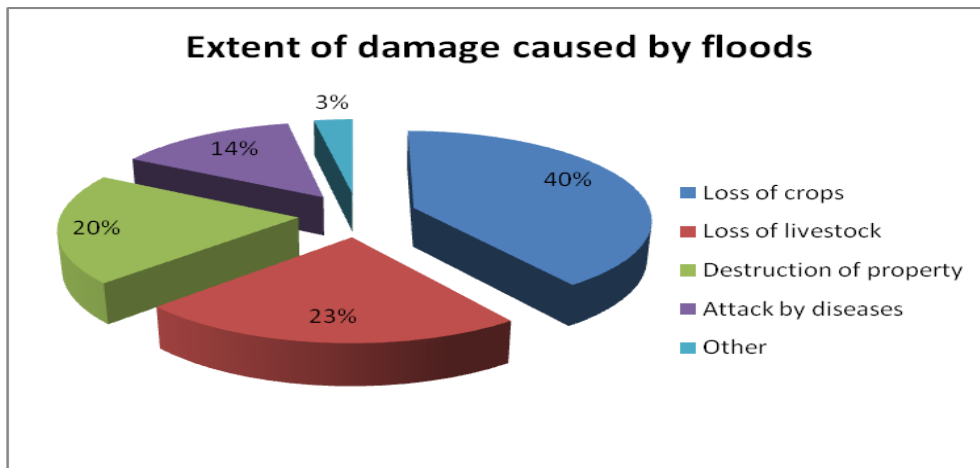
The majority (55.4%) of the respondents interviewed during the household surveys in the Gucha-Migori basin were female. This is partly explained by the fact that the interviews were conducted between 8.00am and 5.00pm, a time when most male members of the household are normally out of their homesteads, fending for the

household’s productive needs. Literacy levels of the respondents were high, with 77% of those interviewed reporting attainment of primary school level of education, or higher. The majority of the respondents ranged between 21 and 60 years.

### Flood frequency and damage extent

The respondents indicated that floods usually occur twice in the year, but is more severe during the long rains (March-April-May). The danger of floods is less severe during the August-September rains, although flooding still affects some areas of the basin. Traditionally, locals predict the likelihood of floods based on the intensity and duration of the rains, so that heavy downpours lasting for six consecutive days is most likely to result in floods within their locality. Additionally, locals also use strong winds preceding the onset of the rains as an indicator of impending floods. The main channels through which the respondents get to receive official information on impending floods are the local churches (38%), government officials (33%) and announcements over the radio (29%). As residents of the basin are mainly agro-pastoralists, damage to crops was reported as, the biggest destructions occasioned by flooding, followed by loss of livestock, that either get swept away by the floods or die due to complications in the aftermath of the floods. Respondents also reported their dwellings and household possessions being destroyed by floods. Additionally, floods in this basin are also associated with a number of diseases, which means households have to contend with hospital bills or reduced earnings when wage earners fall sick. Other damages occasioned by floods reported included (occasional) deaths, particularly of children swept away by raging floods on their way to school.

Figure 1 summarizes the extent of flood damage reported by residents of the Gucha-Migori basin.



**Figure 1. Extent of flood damage in Gucha-Migori basin**

Although respondents reported receiving warnings a number of times before the floods occur, losses still occur regularly. This is explained by a number of factors. First, the flood evacuation centers that exist are few and far between. This means they can hardly accommodate all villages, together with their possessions (livestock and household items) for the entire duration of the floods. The items left behind at home are therefore more likely to be damaged. Secondly, crops would still be swept away regardless of the warnings as such warnings often come when the crops are already in the fields. Thirdly, losses associated with sickness were attributed to the inability of the Government and humanitarian agencies to provide the necessary food, drugs and sanitary facilities in time so as to arrest disease outbreaks in the aftermath of the floods. Although many respondents were not able to accurately assess the monetary value of household losses attributable to floods, the estimated median losses was in the KES 20,001–40,000 category. This is a substantial amount of money, given the high incidences of poverty among the locals in the basin. Instructively, residents also reported that the floods tend to alternate with droughts, which also cause major losses to locals. Up to 64% of those interviewed rated the last flooding incident in their locality as having been ‘very severe’; suggesting that the danger associated with flooding within their respective localities has been increasing over time.

### *Existing flood protection plans*

The Migori-Gucha basin being a flood prone area, the communities have come up with some protection plans in form of hand-dug drainage channels, shallow dams and low dykes to attenuate the impact of floods within their localities. Residents also reported widespread adoption of raised building foundations, especially when putting up permanent structures. These measures however are only effective within the higher altitudes of the basin, as those whose villages sit deep into the floodplains still report damages despite local efforts to cope with floods. Much of the flood local protection infrastructure within the basin is developed by community members themselves, with the church and NGOs/CBOs also being important actors in this regard. On a number of places, the dykes and other structural infrastructure erected by the Government have fallen apart, owing to poor maintenance and the increasing magnitude and frequency of floods in the recent past.

### **Flood response, awareness and capacity development**

Most of the respondents reported evacuating their households to the nearest flood evacuation centers whenever they sensed danger of flooding. The most important evacuation centers existing in the basin, and in which respondents reported seeking refuge are located on hilly areas, schools and churches located also on higher altitudes. It is important to note that most of these

facilities are not purposely designed for this extra function, and only suffice due to their location on higher grounds.

With regard to community training on flood management, over 75% of the respondents reported not having attended any flood management capacity development or training programmes in the past. Even among those who reported having attended such programmes, participation was not regular as respondents reported having attended such meetings only once or twice in the past. The training programmes are mainly organized by Government institutions and the church, and those who had attended them reported having learnt important lessons on flood management.

### **Flood Hazard Mapping**

The study conducted a Flood Hazard Mapping exercise in the Gucha-Migori basin. This involved picking of coordinate data along the areas known to bear the greatest impact and vulnerability to flood hazards using GPS technology. Also of concern were critical facilities such as schools, hospitals, churches, dams, raised grounds within the localities and water points which have in the past either been affected by floods or utilized as flood rescue centers whenever the flooding problem occurs. The areas mostly affected in past flood events are discussed in the following section. For ease of presentation, these locations are grouped per district. It should be noted however that owing to the topographical make-up of the basin, much of the flood damage is experienced in the lower reaches of the two rivers, which lie in Migori District as opposed to the higher altitudes in Gucha and Kisii areas. As such, most of the areas covered during fieldwork lie within Migori District.

### **Angugo and Nyora villages of Migori District**

The area in this locality is fairly flat. The villages are located right at the centre of the Kuja flood plains, which are also traversed by local tributaries such as Angugo River. It

is generally a high risk area, with only a sprinkling of economic activities such as farming due to severe flooding incidences that have occurred in the recent past. Schooling activities especially at Angugo Primary School are often disrupted during the long rains in April, May and June as the school is normally marooned, when the area gets inundated by floodwaters.

There exists two Flood Rescue Centres (FRC) in the area. These are located on slightly raised grounds (Figures 3 and 4). These are Modi Primary School, towards the shores of Lake Victoria, and the PEFA Church in Angugo. Both are situated within Central Kadem location.



**Figure 2. Modi Primary School rescue centre** (Source: Fieldwork, September 2011).



**Figure 3. PEFA Church rescue centre, Angugo** (Source: Fieldwork, September 2011).

### **Kabuto Village Migori District**

This is another flood hotspot in Luanda Konyango location of Nyatike Division. The area is one of the most affected in the whole

basin as it exists on an extensive floodplain (Figure 4). The floods have had devastating effects on local residents, including loss of human lives, livestock, crops and even relocation to alternative land in Macalder area by the Government. A lot of other people who originally owned land in this flood plain have moved to higher grounds in Nyakweri, some 3 KM afield. Severe flooding incidents, which claimed lives of innocent school-going children in the past, eventually saw the relocation of Kabuto Primary School to an alternative site in Aneko location.



**Figure 4. The floodplains of Kabuto**  
(Source: Fieldwork, September 2011).

#### **Kimai and Tulu flood plains of Migori District**

These are low-risk areas due to the fact that River Kuja changed its course from this area to its current course through Aneko location. The residential areas in Tulu are however located on hilly areas that are flood free zones. Flooding in these areas are more as a result of surface runoff in the extensive swamps of Kimai and Tulu. The evacuation centre that serves the area is Tulu primary school.

#### **Nyakweri Trading Centre of Migori District**

This trading centre is used as an evacuation centre, owing to its location on a fairly raised ground. However, the lower parts from the market centre experiences mild flooding during heavy rains. This is caused by storm

waters flowing in from the surrounding areas.

#### **River Kuja and Migori confluence of Migori District**

The area is greatly affected due to high volumetric discharge of water from both River Kuja and River Migori (Figure 5). The most affected areas are farmlands that are located along the river banks. The villages along this zone (Nyandiema and Sango) are located on hilly areas that are free from floods.



**Figure 5. The confluence of rivers Gucha and Migori at Sango**  
(Source: Fieldwork, September 2011).

The confluence is a critical point along the basin as it is primarily used as a boat crossing point that links Sango and Nyandima villages (Figure 7). During flooding, navigation through the river becomes difficult forcing residents to take long routes, severely hampering economic activities in the process.



### **Figure 7. Navigating across the Gucha-Migori River at Sango**

(Source: Fieldwork, September 2011).

#### **Ongoche of Migori District**

Ongoche area is generally flat and is located directly along the flood plains of River Kuja. It is therefore considered a high risk area. Besides, it has a high concentration of population, owing to the fertile lands along the floodplain. Past floods here have led to several facilities, including schools being abandoned (Figure 6) as villages flee to higher grounds in order to cope with floods.



**Figure 6. An abandoned school on the banks of River Gucha** (Source: Fieldwork, September 2011).

#### **Aneko of Migori District**

This area is a high-risk zone affected by storm waters from the surrounding areas of Got K'Ochola as they gravitate into the Migori River. The flood risks are however not high due to the change of River Kuja course which has also led to the formation of a swamp on the lower parts of the old channel. Farming activities and human settlements have however mushroomed along the old river course and the swamp, despite the looming danger associated with river rejuvenation. The receding level of the lake has also provided a good agricultural land to the residents of Aneko, especially along the beaches. These activities further expose the residents to flood risks particularly in the event of submergence of the land, in the event of a surge in lake water levels.

It is important to note that the Aneko flood plain is sandwiched between the great Kuja River and Migori River. This critical location greatly heightens the risks associated with flooding, particularly during heavy rains.

#### **Gogo Dam in Migori District**

Gogo Dam is a low-risk area due to the hilly terrain that confines the river to its channel. From oral histories recorded from local residents, the area was a major flood risk in the 1950s and 60s. However the construction of the dam has since played a major role in controlling flooding in the basin. A high rate of siltation of the dam has however led to occasional flooding of the nearby farms. In fact, the siltation problem is so bad that the dam has literally been reduced to an over-stream flow, as its water-holding capacity has reduced drastically. This has since rendered it less useful as far as damming and flooding control is concerned.

#### **Gucha District**

As already stated, Gucha District lies on a higher altitude within the Kisii highlands. Accordingly, a rugged terrain that confines the river into narrow gorges, but simultaneously increases the intensity of storm water discharged downstream characterizes the Gucha River basin. Another problem in this part of the basin is landslides, which happens as loose soils give way, following heavy downpour. The few noted flood plains in this part of the basin are located along River Gucha, especially at the confluence with River Mogunga in Ogembo area. The most affected areas are farmlands located along the river banks. Just as an indication of how bad the area gets affected during floods, the operations of the Gucha Coffee Factory had stalled at the time of field work, due recent flooding incidents along the river.

#### **Recommendations for the Gucha –Migori River Basin Flood Management Strategy**



## Nyatike District

### I- Structural interventions:

#### a) Kabuto Area

- 1) Building of dykes.
- 2) Digging of check dams along the river Gucha.
- 3) Constructing of bridges across river Gucha.
- 4) Massive planting of trees spanning 100m along the river to stop it from eroding and expanding its banks.
- 5) Tarmarking of the roads.
- 6) Introduction of irrigation as a farming system.
- 7) Building well equipped evacuation centers.

#### b) Gogo Dam Area

- 1) Since the dam has become shallow and bushy due to siltation, it would be necessary for the dam to be dredged and expanded if possible.
- 2) The Gogo bridge should be expanded as well because it is very narrow and this has led to the deaths of many children who fall over while crossing through it.

### II- Training/ Capacity Building Initiatives

- 1) Mainstream Integrated Flood Management methods.
- 2) Enhance Modern livestock and crop farming skills in flood prone areas.
- 3) Improve on Irrigation Farming skills.
- 4) Initiate Water harvesting and storage techniques for use during drought.

## Gucha District

### I- Structural interventions

The area is mainly characterized by steep slopes hence intense soil erosion. The following structural interventions are recommended:

- 1) Construction of gabions along the banks of river Gucha to avoid bursting and sweeping of crops in farmlands along the river bank.

- 2) Digging of trenches and construction of dykes across the slopes to mitigate erosion
- 3) Introduction of Irrigation farming systems

### II- Capacity Building/ Training

- 1) Education on irrigation farming techniques using the river water
- 2) Education on soil conservation (soil erosion control) techniques
- 3) Training on flood disaster preparedness and mitigation measures
- 4) Training on appropriate architecture and building techniques to cope with floods.

### Conclusion

Based on the foregoing study on the Gucha-Migori river basin, a number of common findings are worth noting. To begin with, most of the local populations in the areas covered by the study are poor households and largely dependent on peasant livelihoods in various forms, including crop farming, livestock rearing and fishing. All these activities are highly susceptible to flood disasters, meaning that losses are predictably high whenever floods occur in these areas. This is over and above the losses suffered in terms of deaths, destruction of dwellings and other community facilities, and cost of treatment due to flood-related illnesses. Flooding events occur twice a year with a fairly predictable frequency, but have been becoming more and more severe in the recent past.

In all the areas affected by floods, the existing flood evacuation and rescue centres are few and far between. Besides, most of these facilities – mainly schools, health centres, churches and markets – are themselves not structurally designed to withstand the impacts of floods. These facilities furthermore, are ill equipped in terms of support infrastructure like water and sanitation to accommodate the usually large number of households seeking refuge from floods at any one given time. In areas where

such facilities do not exist, people relocate to high grounds such as hilltops. While this may offer temporary solution to the problem, households and their belongings remain exposed to the elements and susceptible to public health hazards such as disease outbreaks.

Although respondents reported receiving early warnings on impending floods, losses still occur regularly. This is explained partly by the limited number of evacuation centres available. Because they are few, these centres can hardly accommodate all villagers, together with their possessions, including livestock and household items. The items left behind at home are therefore more likely to be damaged. Losses are also attributed to the inability of the state and humanitarian agencies to provide timely emergency response in the wake of floods. There is therefore need to build structurally appropriate multi-purpose evacuation centres.

Almost all respondents reported the increasing severity of flood events in their locality over the past few years, a fact that is most likely related to the impacts of climate change. For example, asked what the seasons have been like in the recent past, a respondent looked in the distance and sadly offered:

*'Since time immemorial, we have done a good job predicting the onset of rains and the intensity of impending floods. We were thus able to prepare ourselves psychologically for the inevitable. Not anymore! Seasons have changed and with it, the weather patterns. The floods have become unpredictable and we are often caught unawares, meaning we lose all our meagre possessions, year in year out. At this rate, we fear the waters will one day sweep us all with it into the Lake!'*

This was a 75-year old man, who has lived by the Kuja all his life. To him and his fellow villagers, the future looks very bleak. He is right in noticing that the seasons have changed. However, when it comes to

explaining the cause of these changes, he and many members of his village are at a loss.

In most areas, residents have marshalled local resources and put in place a number of structural measures to lessen the impact floods in their villages. These include hand-dug drainage channels, shallow dams and low dykes. This has however done little in ameliorating the problem because the structural integrity of such community-constructed structures is compromised by the limited resources, the rudimentary techniques available for putting them up, and the sheer strength of river waters surging at full force.

Limited training in flood management has taken place among local communities. The training programmes are mainly organized by NGOs such as the Kenya Red Cross, and those who had attended them reported having learnt important lessons on flood management. This means that there is a high likelihood of training uptake at the community level, given the high literacy rates reported in all the three sub-regional catchments. Hence more sustained efforts in community capacity building on Integrated Flood Management techniques should be increased.

In general, a systematic process of using administrative directives, organizations, and operational skills and capacities to implement strategies, policies and improved coping capacities in order to prevent or lessen the adverse impacts of flood hazards and disasters should be put in place as a flood disaster risk management strategy.

## References

- Government of Kenya.** (2009). *Draft National Policy for Disaster Management in Kenya*. Nairobi: Ministry of State for Special Programmes/Office of the President.
- Mutimba, S., Mayieko, S., Olum, P. and Wanyama, K.** (2010). *Climate Change*

- Vulnerability and Adaptation Preparedness in Kenya*. Nairobi: Heinrich Böll Stiftung
- Ministry of Water and Irrigation.** (2009). *Flood Mitigation Strategy*. Nairobi, Kenya.
- Ocholla, P. O.** (2010). *The Impact of Flooding Characteristics of the Nyando River on Cotton Cultivation in Lower Kano Plains in Nyando District, Western Kenya*. Department of Hydrology.
- KwaDlangezwa:** University of Zululand, South Africa.
- UNDP.** (2011). *Kenya Natural Disaster Profile*. Accessed September, 2011 from [www.undp.org/kenya/KenyaDisasterProfile.pdf](http://www.undp.org/kenya/KenyaDisasterProfile.pdf).
- UNEP.** (2009). *Kenya: Atlas of Our Changing Environment*. Nairobi: United Nations Environment Programme.

# Fallacious Sexuality Knowledge and Its Implications among the Akamba Adolescents in Machakos County, Kenya

By

Felix N. Kioli<sup>1\*</sup>, Peter G. Oino<sup>1</sup> and Sussy Gumo<sup>2</sup>

<sup>1</sup>*Department of Sociology and Anthropology, School of Arts and Social Sciences, Maseno University*

<sup>2</sup>*Department of Religion, Theology and Philosophy, School of Arts and Social Sciences, Maseno University*

\*Corresponding Author: [felixngunzo@yahoo.com](mailto:felixngunzo@yahoo.com)

---

## Abstract

This paper is premised on the findings of a study carried out among the Akamba people of Machakos County, Kenya. The study was part of a research project sponsored by OSSREA within the theme, *Insights into Gender, Equality and Power Relations in Sub-Saharan Africa* between 2012 and 2013. The research design was descriptive. Data for this study was collected using various qualitative and quantitative methods from a study sample of 240 adolescents arrived at using systematic sampling procedure. There were also 25 key informants purposively sampled. The findings demonstrate that contemporary Akamba adolescents are bereft of accurate sexuality knowledge. The paper posits that the contemporary Akamba adolescent is in a vulnerable position due to the wrong messages and lacuna of knowledge on topical sexuality issues which engenders indiscriminate sexual indulgence. This kind of scenario predisposes them to STDs/HIV/AIDS, unwanted pregnancies, abortion, surreptitious marriages, among others. Ignorance and fallacious sexuality knowledge among adolescents is explained within the backdrop of collapsed traditional structures and institutions that controlled, counseled and guided adolescents on sexual development and behavior. The paper concludes that ignorance and fallacious sexuality knowledge are as a result of dilemmas on sexuality socialization in the Akamba society. Indeed, fallacious sexuality knowledge is the jinx as well as Achilles heel upon which contemporary Akamba adolescent sexuality is premised on. It recommends that Comprehensive Sexuality Education should be institutionalized within the family as well as in other socially supportive institutions.

**Key words:** Adolescent, Counseling, Fallacious knowledge, Sexuality, Sexual Behavior.

---

## Introduction

The adolescence denotes a period of transition from childhood to adulthood. This stage calls for proper induction into the norms and regulations of the society. Adolescence is a cultural construct that

varies across settings and contexts (Were, 2007). In most contemporary societies people feel that it does not make sense to talk about adolescence openly. For instance, in many rural areas of the developing world, adult responsibilities including family

formation and labor force participation are taken on very early in life, without any significant transition period. In many languages, neither the word “adolescent” nor the concept exists. For example, in India adolescence is a controversial notion. It is viewed as an artifact of the extended formal education in the West, and language-wise females are ‘girl children’ until they marry (Greene, 1997). In Kenya, where adolescent fertility is reported to be among the highest in Africa, sexual custom varies greatly among ethnic groups, with differing values on virginity, consequences of premarital pregnancy, practice of genital mutilation, level of knowledge and use of contraception, among other characteristics (Ocholla-Ayayo *et al.*, 1993).

One of the key areas which most cultures fervently observe either directly or indirectly during adolescence is their sexuality. According to World Health Organization (1998), sexuality is part of the holistic human personality. It incorporates sexual identity, gender roles and duties, reproductive health, attraction, relationships, sexual intercourse and other forms of sexual behaviors. In the endeavor to understand the sexuality of the adolescents, it is important to note that most of its components are strongly a product of cultural orientation. The view that sexuality aspects are as a result of cultural orientation is predicated on the social learning theory which observes that behavior is a learned phenomenon.

The systematic studies of social learning have been widely used by various social scientists and seem to agree that human behavior is a result of the process of learning throughout the life cycle. Albert Bandura (1977) and Walter Mischel (1973) are the architects of the contemporary version of social learning theory, which initially was labeled cognitive social learning theory. A synonym of social learning as applied by sociologists is the concept socialization while anthropologists use the equivalent, enculturation. Significantly, the social context of the adolescent, especially the

parents and family members, peers, mass media and the community at large are crucial in understanding their behavior, including sexuality. For instance, among the traditional Akamba people, family members were significant in preparing young people for adult roles including education on responsibilities of sex, marriage and child rearing.

According to Kalule (1987), the grand parents, parents, aunts and uncles as well as siblings augmented each other in communicating sexuality principles. This was in addition to the role played by the community of initiating the young people to become well adapted members of the Akamba culture. Mbiti (1969) observes that family role in socialization became crucial after the first initiation, that is, “Nzaiko nini” and the second initiation “Nzaiko nene”, meaning minor and major initiations, respectively. Both initiations took place away from home and occurred before onset of puberty. Minor circumcision involved physical removal of the penis foreskin (males) and clitoris for females, what anthropologists refer to as clitoridectomy (Akong’a, 1986). Major circumcision entailed induction and integration into Akamba peoples’ way of life, including sexuality matters. It was a well organized kind of education and the Akamba community described that as “brooding over the initiates” the way the birds’ brood over eggs before hatching them (Mbiti, 1969).

Albeit parents are the main source and conduit of information on sexuality issues in developed and developing societies, there remain silence between most parents and their adolescent children on sexuality matters. Studies have shown that only 46%, 20%, and 20% of parents in USA, Lesotho, and Ethiopia, respectively, had discussed such issues with their adolescents (Tesfaye *et al.*, 2014). In China, only one-third of female youths talked to their mothers about sexual matters (Ahlberg *et al.*, 2001; Taffa *et al.*, 1999; Dittus, 2003). As a result, most adolescents’ patchy knowledge on sexuality

issues often comes from information shared by their same sex peers, who may or may not be well informed. This can lead to misinformation and the persistence of damaging myths, making young people vulnerable to unprotected sex, unwanted pregnancies, sexually transmitted diseases, and unsafe abortions (Dittus, 2003).

One critical aspect highly emphasized and safeguarded amongst the Akamba people of Kenya was unwanted pregnancies. Ndeti (1972) points out that although Akamba culture is the only documented society in Kenya that allowed young people to have sex before marriage in traditional periods, premarital pregnancies were unheard-of. Any girl who became pregnant before marriage was married off to Akamba neighbors cheaply or married as a subsequent wife to an old man. Men or young men who impregnated girls were highly penalized. Indeed, the Akamba socialization process for the young people underscored the need for extra conscience on sexual interaction endeavors to avoid outcomes perceived to embarrass not only the family, but also the society.

Learning from family members was further reinforced by peers and the community at large. Akong'a (1986) points out that the child among the Akamba people belonged to the entire society and each had a stake to their growth. Community members, especially neighbors would administer punishment, guide and admonish young people on pertinent issues while peers acted as a check to each others behavior. Accordingly, family members, peers and community controlled and checked the behavior of the adolescents, and all endeared themselves towards production of a well adjusted person, keen to sustain the community.

The above discourse demonstrates that the kind of environment surrounding the adolescents is key to the kind of knowledge and values they acquire, especially on sexuality which ultimately determine how

they respond to their sexual needs now and in their future life. This study endeavored to examine contemporary parents and family members' role as well as peers, mass media and community in communicating sexuality matters.

## **Methodology**

### ***Study Design***

The design of this study was descriptive. Descriptive design was crucial in collecting information about the people's attitudes, opinions, habits and knowledge about sexuality, as a social issue. The study utilized qualitative and quantitative methods of data collection.

### ***Study Area***

The study was carried out in Machakos County, Eastern Province, Kenya. Machakos district is predominantly occupied by the Akamba people, the fifth largest ethnic group in Kenya numbering around 3.5 million people (11% of the total population) (GOK, 2009). The district is the largest of all the other three Ukambani region districts namely, Makueni, Mwingi and Kitui. Apparently, these other three districts sprang from Machakos district, which happens to be the epitome and embodiment of the Akamba culture.

### ***Study Population, Sample Size and Sampling Procedure***

The study targeted school going adolescents in age category 12–19 years, with class 8 representing adolescents in 12–15 year age category and form four adolescents for the 16–19 years old category. Machakos district with 12 administrative divisions had 155 secondary schools and 795 primary schools in 2008, all spread almost evenly in the 12 divisions. Out of the 12 divisions, simple random probability sampling was used to choose and concentrate the study in only six divisions. From the six selected divisions, one secondary school and a primary school were selected, purposively. The main reason for using purposive sampling was to ensure both urban and rural school set ups were to

be represented in the study equally. In total, six primary schools and six secondary schools (all mixed) were chosen. The choice of mixed schools was based on the assumption that, in such schools where boys and girls interact at close proximity, sexuality issues are likely to be more manifested than in single sex schools.

The study sample involved ten boys and ten girls from each division who were chosen from a population of approximately 1200 pupils. This represented 10% of the total study population for each category, which is the minimum allowable sample size in descriptive survey studies (Southward, 1978). Thus, in total, 120 boys and 120 girls formed part of this study. For the purpose of arriving at the 10 boys and 10 girls for every school category, the assumption was that each class had 50 students and this was divided with the required number of 10 students ( $50/10 = 5$ ). Thus, the sampling interval was 5 (five). Subsequently, the class register of names was used in each school and through systematic random sampling procedure, every fifth student was picked from the register until the total number required. This applied for both girls and boys. The study sample in the lower adolescence (12–15) years was 120 adolescents (60 boys and 60 girls), while the same applied for secondary schools, totaling to 240 adolescents. The nature of the study also required further application of purposive sampling in selecting key informants. In total, 25 key informants, that is, 6 village elders, 6 teachers, 6 parents, 2 church leaders, 2 social workers and 3 medical practitioners participated in this study. A combination of key informants from each category was also purposively sampled for a focus group discussion.

#### ***Data Collection Methods and Analysis***

Data for this study was majorly collected using various qualitative methods and augmented by quantitative method. Choice for qualitative methods was because of the sensitive nature of the topic. Sex is a private, individual, sensitive and taboo subject,

which cannot easily and openly be discussed particularly within the context of many contemporary African cultures. In view of this, it can significantly be captured through use of qualitative data collection techniques.

Focus group discussions (FGDs) were conducted with three groups of respondents, one each at secondary school and primary school levels, and the other with key informants. In-depth interviews and narratives were carried out with 25 key informants while the non participant method was used for the various behavioral patterns of the adolescents as well as social environment of the adolescents. Further, Self administered questionnaires were administered to the 240 adolescents to reinforce qualitative information. FGDs, in-depth interviews and narratives were recorded and transcribed into several themes and offered useful information for direct quotations, texts and verbatim. Data from self administered questionnaires was analyzed by use of Statistical package in the Social Sciences (SPSS) and Microsoft Excel which were crucial in developing proportions (percentages), averages and tables.

#### **Results**

Adolescent boys and girls featuring in the study were asked to state their main source(s) of information on sexuality as well as the contents or kind of information received. In their responses, adolescents offered variety of answers, but the mass media emerged as the predominant source of sexuality message comprising 93 (38.7%) of the total adolescents. The other crucial source of sexuality information was the peers accounting for 54 (22.5%). Family members and schools accounted for 44 (18.2%) and 27 (11.2%), respectively. The church had a minimal of 9.2%. A significant figure 62 (25.8%) of adolescents said they did not consult on sexuality matters from any of the above sources.

### Mass Media Communication on Sexuality Matters

The Mass Media emerged as the most profound agent of socialization in exposing adolescents to sexuality issues in this study. The main components of the mass media in constant contact with the adolescents in terms of prominence included the television, internet, cinema, radio, newspapers, books and magazines. In order to assess the level of exposure to the mass media, adolescents were asked to state the kind of media

information they liked or identified with in both the print and electronic media. Significantly, mass media programs and messages inching on romance and eroticism were reported as the most popular. For instance, responses to the adolescents on favorite television programs suffice. By order of preference, soap operas emerged as the most popular as shown in table 1, watched by 50 adolescents (20.8%) followed by music 20 (8.3%) and TV movies 4.7%.

**Table 1. Percentage Distribution of Favorite TV Programs among Adolescents**

Favorite Programs	Number of Respondents	Percentage (%)	Cumulative Percentage
Soap Operas	50	20.8	20.8
Music	20	8.3	29.1
TV Movies	11	4.7	33.8
Comedies	8	3.3	37.1
News	8	3.3	40.4
Do not watch	143	59.6	100.0
Total	240	100	100

A closer observation to the soap opera's or serial programs running in the Kenya television networks revealed that a majority of their episodes and main themes were pegged on romance, drugs or violence. The most classic example was the 'Bold and Beautiful', apparently running in the Kenyan media (KBC) for over 20 years, and happened to be the most popular. Incidentally, this soap opera rotated on romantic and incestuous affairs between family members.

### Sexuality Communication with Parents and Family Members

Communication with Family members on sexuality matters was minuscule, couched in secrecy, indirect and euphemistic language. Parents, grandparents, siblings have abdicated their roles due to location, language incompatibilities, generation gap and confusion caused by peers and mass media. One of the key objectives of this study was to explore the nature of communication between parents and family

members on sexuality matters with the adolescents.

Adolescent boys and girls featuring in the study were asked to state their main source(s) of information on sexuality as well as the contents or kind of information received. In their responses, adolescents offered variety of answers, but the mass media emerged as the predominant source of sexuality message comprising 93 (38.7%) of the total adolescents. The other crucial source of sexuality information was the peers accounting for 54 (22.5%). Family members and schools accounted for 44 (18.2%) and 27 (11.2%), respectively. The church had a minimal of 9.2%. A significant figure 62 (25.8%) of adolescents said they did not consult on sexuality matters from any of the above sources.

The study sought to know with whom the adolescents (the 44 students) discuss with on sexuality subjects, among family members. The parents to the adolescents (mother and father) took the leading role, with



grandparents, uncles and cousins playing an insignificant role. Table 2 shows that mothers took the ultimate position (56.8) in informing adolescents on sexuality matters.

**Table 2. Sexual Behavior Communication with Family Members, Percentage Distribution**

Family members	No. of those spoken with family members	Percent	Cumulative percent
Mothers	25	56.8	56.8
Fathers	10	22.8	79.6
Siblings	3	6.8	86.4
Grandparents	2	4.5	90.9
Uncles	2	4.5	95.4
Aunts	1	2.3	97.7
Cousins	1	2.3	100
Total	44	100	100

It was imperative to note that only 44 (18.2%) students out of 240 reported to have their sources of sexuality information from family members. This low proportion was attributed to the fact that adolescents spent most of their time in school, and the situation was exacerbated further by the existence of boarding schools for both boys and girls.

As reported, most boarding school authorities discouraged parents from visiting the institutions to meet their children unless on invitation, making the parent-child interaction minimal. This implied that most adolescents met their parents and other family members during holidays and in other cases for a very short time since, some schools ran private tuition studies during holidays, when apparently the adolescents were supposed to have contact with their parents. The study found out that young people in schools totally lacked valuable time to be with their parents and family members for any qualitative talk on sexuality issues, and an elongated period of school time prompted weakening of parent-child bond.

Additionally, majority of the parents were reported to be too busy in the money market to hardly afford any time to be with their children. For those parents who were close

with their children, they could find it uncomfortable to discuss sexuality issues with their children. This is also confirmed by Kamau (1996) who found that many parents were uncomfortable discussing sexuality and contraception with their children, a role that they had left to schools that have already scant information on sex education.

A very desperate situation was narrated during FGDs with the adolescents of a case where the girl student hardly had any contact with her father. The father was employed and living in Nairobi city while the rest of the family was in rural Yatta division, Machakos district (almost 150 kilometers apart). He came home once a month, arriving Saturday night, then leaving on Sunday the following day—for another long wait to see him again the following month. Such cases of absenteeism or long distant fathers or as reported by one adolescent boy during FGDs, “Technical appearance Dads”, were cited across all the divisions in Machakos District. By implication, the father input was lacking or very minimal in the socialization process. Researches indicated that increased parent-child communication and presence in their families leads to a raised awareness and reduction in risk taking sexuality behaviors (Huberman, 2002). On the other hand, when young people feel unconnected to home and

family, they may become involved in sexuality activities that put their health and wellbeing at risk (Ahlberg *et al.*, 2001; Barbara and Kirsten, 2002; Wang *et al.*, 2007).

Mothers played a pivotal role in communicating sexuality matters to the young ones. The fact was that they spent more time at home and in close proximity to the adolescents. Indeed, most adolescents, especially during FGDs reported to be freer with their mothers on sex matters than fathers. The latter were said to coy from the topic in spite of also being absent. When they do, they became harsh and sometimes physical-“even in small matters like having been seen walking with a girl or a boy,” as reported by several adolescents. Mothers’ communication with adolescents provided some insight into the use of metaphoric language in advising.

They were instrumental on advising on abstinence, pregnancies and STDs/HIV/AIDS, though without the use of direct language. For instance, use of language like, “hope you are careful of the new bad disease” meaning HIV/AIDS or “do not do bad things” meaning don’t have sex. Others were noted to say, “be careful with boys,” and yet they did not provide clear reasons. They did not mention the issues directly. This was further reinforced with using real examples of cases in the village of those victims of teenage pregnancies and HIV/AIDS as an aspect of warning; that is, “ensure you do not become like so and so!” Further, parents were reported to be significant in advising and warning about “bad” companies and in other cases, went to the extent of choosing friends for the young ones. Moreover, as noted from FGDs, information on contraceptives as well as clarity of information about STDs/HIV/AIDS from parents to adolescents was very scanty.

In personal communication with several parents in Machakos District during fieldwork, one could deduce that

contemporary generation of parents is usually troubled and confused about how much sex information to give to their children. They similarly do not know what kind of information to provide to their sons and daughters. A fundamental observation was that most parents said nothing, and “kept their fingers crossed,” others offer very superficial, vague advices and stern warnings totally incompatible with the situations on the ground.

A critical observation about parent-child relationship cited from both questionnaires and FGDs was that parents could, in some cases, be bad role models pertaining to sexuality. Several respondents reported having knowledge of parent(s) sexually cheating on each other, thus, such a parent could not be relied on to offer proper guidance on sex matters. This also eroded trust. Cases were also cited of parents who had sex from locations or positions where young ones could discern what was going on. This happened in situations where parents shared the same house or bedroom with children or had sex when inebriated in total disregard of their children’s presence.

Besides, 3 episodes were narrated of possible incestuous relationships between fathers and daughters. One case was in Kalama division, Machakos district, where the girl involved with her father was in standard eight (around 14 years) and the case was before extended family elders. It was the mother to the girl who had reported the case to the family elders. Indeed, she had found both culprits in a compromising situation and sought family elders’ intervention. The case was ongoing during the time of field work and, after interviewing one of the elders, it emerged that the father to the girl was trying to evade the issue, citing having been very intoxicated (alcohol) during the sexual episode. To him he had, “thought it was his wife”. The other two cases were reported in Central division, Machakos district, whereby in both circumstances, the fathers were widowers (single fathers), with adolescent girls under their care.

In one of the cases, the father had already been found guilty of raping his daughter and jailed for 23 years, while in the third case, a man was staying with his mentally retarded daughter of around 20 years. This girl had several miscarriages and “fingers of suspicion” were being pointed to the father for being responsible for her serial unfortunate pregnancies. The mother had died several years back, she had a brother residing some distance with his young family, while the other sister was married. The community around including the elder interviewed appeared helpless in salvaging that girl from the abusive father, a phenomenon that could not have happened in the traditional Akamba culture.

Communication with grandparents, aunts and uncles was very minimal as indicated in table 1, and further complemented by information from FGDs. The study found out that there was horrendous disconnect between adolescents, their grandparents, aunts and uncles and consequently, their role in educating and socializing the young ones on sexuality matters was steadily becoming obsolete. The plausible reasons offered for this seemingly growing vacuum was location and residential disparities, that is, parents to the adolescents and their close relatives residing far from each other, minimizing contact unless on very rare occasions. This location disparity and long-term absence from interacting with each other has systematically led to interest incompatibility between adolescents and their elderly relatives. Other reasons included language barrier between grandparents and the adolescents while, the issue of generation gap also appeared very critical.

The study revealed that some parents, uncles, aunts and by extension grandparents were as well victims of “modernity” thus, too incapacitated to offer any firm, solid and valuable socialization. Additionally, children were reported to be confused about who a real “uncle” or “aunt” was since any mature person, be it a house help, driver, family friend, etc, were all branded these name tags.

This underscored the concern for proper relatives naming and kinship classifications in the contemporary Akamba societies and families.

The role of siblings and cousins in accounting for adolescent sexual behavior was ostensibly noted in the study. It was apparently cited in the questionnaires that young people initiate consensual sexual relations with their young cousins. This was complemented by FGD reports with adolescents. Indeed, quite a number of early childhood sexual relations were accounted for being between very close relatives including cousins, who may not have known that it was culturally unacceptable. On rare occasions, adolescents reported cases of sibling-to-sibling childhood sex especially in imitating their parents and mostly occurred in child plays or in sharing same bed. Older siblings were reported to be notorious in introducing the young ones to such “child games’.

### **The Role of Peers and Community in Communicating Sexuality Matters**

The study sought to explore the major issues adolescents discussed amongst themselves as appertained sexuality. A significant proportion of the adolescents (50.4%) discussed issues classified under likely to influence one to irresponsible sexual behaviors while 35% discussed matters likely to lead to responsible behavior. The rest discussed nothing at all. In the category of matters likely to influence adolescents to irresponsible sexual behavior, the respondents enumerated the following, “how sex is sweet”, “sex organs of both boys and girls”, “various sex styles”, “who to have sex with”, “how many girlfriends make one popular”, most beautiful girls around”, “how sex felt with a certain girl”, and “girls’ boobs/buttocks”. More boys than girls appeared notorious in basing their sexual talk on issues likely to compel one another to experiment. Girls also help each other in detecting safe days in order to avoid pregnancy while others dwell on boyfriends

and most ideal “guys”, popularly known as “beste”.

The study attempted to explore the role of community in understanding adolescent sexuality. In particular, of interest was to establish whether there was a forum in the Akamba society where young people assembled to be socialized on certain topical issues affecting their growth and development. In response to the above, over half of the respondents (50.9%) reported that such a forum did not exist, 48.3% indicated such forum existed, while 0.8% had no response. Church leaders and teachers played an insignificant role in sexuality socialization.

### **Knowledge on Sexuality Issues by Adolescents in Machakos District**

#### ***Knowledge on Contraceptives and Usage***

The study sought to establish adolescent’s knowledge on pertinent sexuality issues including contraceptives and their usage. The Akamba adolescents in Machakos district demonstrated high level ignorance on the existence of other contraceptives apart from the condom. Moreover, in spite of their knowledge about the condom, its use during intercourse was reported to be minimal. In this study, only 52% of both adolescent boys and girls reported to have used the condom during previous sex. The study sought information on the reasons for non-use of condoms during intercourse despite the risks. The reasons provided varied according to sexes of the respondents and epitomized ignorance. Boys reported that most sex episodes were quite unplanned and “fast” thus, difficult to conceptualize about condom. This reason was reinforced during FGDs with adolescents where one boy said, “Unplanned sex does not plan for condoms.” Sex was quite spontaneous and occurred during drama festivals, games competitions, in discos and sometimes inside cars and school buses. Some environment may not have been conducive for proper configuration to protect oneself with a condom according to the adolescents.

Moreover, there emerged use of indirect language and slang in offering reasons for non-use of condoms. For instance, boys were cited talking metaphorically that, “*unawezaje kula peremende na karatasi yake?*,” translated to mean, “how can you chew sweet together with its cover.” Other noted indirect use of language included, “*kumanga na hiyo ninii ni kutia zii,*” translated to imply that the use of condom reduces pleasure and does not give them all the “fun”. Likewise, boys as reported from both FGDs and questionnaires, felt other deterrent factors were embarrassment to purchase the condoms over the counter because of the social and sexual connotations attached to condoms; that condoms hurt their machismo and that it was against their beliefs to interfere with nature.

Concerning adolescent girls and condom use, one glaring observation during FGDs was that girls were reticent and reserved in discussing sexuality matters while in front of others and more so, condom issues. But certainly, what emerged was that girls leave it to their partners to avail the condom during intercourse, and concerted insistence to use a condom by a partner raises suspicion of unfaithfulness and wanton sexual involvement with “others”. Adolescents also reported that the failure to use condoms was due to fact that the very best ones were very expensive and not within their reach. One adolescent boy conspicuously reported use of a balloon during intercourse and further clarification during FGDs indicated that some boys even tie polythene papers to their genitals during intercourse! This is meant to deceive the other partner (girl) that they have a condom. Cases were also reported of boys pinching to tear the tip of the condom during intercourse.

A salient feature in the use of the condom device by the sexually experienced adolescents was that it was higher among the upper adolescents (16-19) than among the lower (12-15). Indeed, 53.1 percent of sexually experienced in the late adolescence used condoms compared to 46.9 percent in

the lower adolescence. Furthermore, adolescent boys and girls reported their anxiety and discomfort in visiting Family Planning (FP) clinics within their environments simply because such clinics are associated with mothers or the elderly, thus, limiting their chances of acquiring FP methods offered free in Government hospitals and clinics. Indeed, it emerged that visiting such health centers one (adolescents) gets ridiculed and stigmatized by fellow

peers. It is also associated with pregnancy test, STD treatment and promiscuity.

Following up the issue of condom or contraceptive use among the adolescents was the question on Family Planning Methods' awareness. Table 3 shows the knowledge of Family Planning Methods among the lower adolescents (12-15) and the late adolescents 16-19 years.

**Table 3. Knowledge of Family Planning Methods among the Adolescents**

Knowledge of FP Method	Respondents		Total	Percent
	(12-15 yrs)	(16-19 yrs)		
Know of FP Method	25	69	94	34.2%
Do not know of FP Method	95	51	146	60.8%
Total	120	120	240	100%

Albeit the proportion of adolescents in the study aware of FP Methods was low 94 (34.2 percent), adolescents in the upper adolescence demonstrated a greater awareness (69) 73.4 percent of FP methods. Of all the FP Methods available in the market, the adolescents universally appeared to be aware of the condom. A significant number of adolescent girls in the age category 16-19 were aware about the pill (Femi plan) and the Depopropellor. An insignificant figure of 6 (4.9 percent) in the entire study population knew about the morning after pill. More girls than boys, and adolescents in the age category 12-15 expressed their ignorance and apathy about contraceptives. One of the hindrances of adolescents' access of knowledge in FP in the Machakos district is culture. Culture defines who is entitled to access reproductive health services, sometimes by social control and at times by laws, policy restrictions or other measures. According to Bledsoe and Cohen (1993), in many African societies,

only married women are required to have access to family planning and other health services, and unmarried pregnant adolescents are particularly affected. In Gambia for instance, provision of contraceptives is legally restricted to married couples and unmarried women with at least one child (Jeng and Taylor-Thomas, 1985).

***Knowledge about STDs, HIV AND AIDS***

STDs, HIV and AIDS are crucial sexuality indicators. Thus, the adolescents' knowledge about how HIV is transmitted was sought as well as awareness about other STDs. Asked to state how HIV was mostly transmitted, predominantly 97% were very conscious to the fact that HIV was spread through sexual intercourse while a paltry (3 percent) reported not to know. Table 4 shows that among the upper adolescence (16-19) knowledge on how HIV was transmitted was almost universal, that is, 99.2 percent; while for the lower adolescence (12-15) was 94.2 percent.

**Table 4. Knowledge about HIV Transmission among the Adolescents**

Mode of transmission	No. of respondents		Percentage	
	(12-15 yrs)	(16-19 yrs)	(12-15 yrs)	(16-19 yrs)
Sexual Intercourse	113	119	94.2	99.2
Do not know	7	1	5.8	0.8
Total	120	120	100%	100%

A crucial observation was that despite the concerted and incessant input by the government institutions, the civil society as well as the media to create awareness about HIV transmission, a proportion of adolescents, and 5.8 percent in the lower category seemed totally oblivious to HIV modes of transmission. This was noted in the schools located in rural areas of Machakos district, Kenya.

In a similar question, adolescents were asked to state the types of STDs they knew about apart from HIV. Compared to HIV whose knowledge appeared almost universal to all age categories during adolescence, there seemed to be a lacuna of knowledge about other sexually transmitted diseases (STDs). Findings suggested that a fundamental proportion of adolescents 70.8% and 70.4 % knew about Gonorrhoea and Syphilis, respectively. Other STDs adolescents knew about but in lower proportions included Chancroid 17.9%, Hepatitis 2.5%, and Chlamydia 0.4%. It is important to point out that a significant number of the adolescents in the entire study 26 (15%) did not know about any other STD apart from HIV.

A majority of those with obscure knowledge about STDs (67%) were from the lower adolescence category (12-15 years). The fact that adolescents demonstrated a large gap in knowing about the existence of other STDs apart from HIV was a manifestation that reproductive health education and knowledge was lacking not only at home but also in school. Further, it was emblematic of the fact that sex education has not been

imbibed in the social learning processes of the young people whether at family, school or society levels. This places them at greater or elevated risk and vulnerability to infection with all forms of sexually transmitted diseases and other complications arising from early and irresponsible sexual indulgence.

#### **Sexual Behavior of Adolescents in Machakos District**

Findings indicated that out of the 240 adolescents, 123 (51.2%) were sexually experienced by the time of the study. Out of these, 66.6% were adolescent boys and 33.4% girls. Moreover, 47.5% of adolescents in age category 12-15 and over 55% in 15-19 year category reported to be sexually experienced. Incidentally, boys seemed to report lowest age of 7 years at first coital relation while for adolescent girls was 8 years. Additionally, over 30% of adolescent boys indicated to indulge in sex with multiple partners compared to 18% of sexually experienced girls. This indicated high exposure in to early and indiscriminate sexual encounters. Further, Akamba adolescents of Machakos district reported to indulge in aberrant sexual behaviors namely homosexuality, group sex (orgies), incest and oral sex.

#### **Complications of Sexuality Involvement**

Teenage pregnancy was reported as the major consequence of early and irresponsible sexual interaction. Indeed, 89.6% of adolescents participating in the study knew of at least a girl, victim of early and unwanted pregnancy. Additionally, key

informants reported to know at least two school going girls who may have dropped out of school due to pregnancy. Abortion was also reported to be highly procured by adolescent girls in Machakos district. It was difficult to come up with exact figures of abortion in the district due to the secrecy, anonymity and confidentiality upon which abortion was reported to occur. Incidentally, Medical doctors confirmed of its existence, and it was reported to be quite rampant in the month of April and May (during holidays), a clear manifestation of an accelerated sexual activity during the long December holidays.

Cases of girls dying in attempts to procure abortion, self induced or through back street abortionists, while girls being presented to hospitals with incomplete abortions and complications were quite common. Moreover, surreptitious marriages for girls, and school dropout due to pregnancy were a common phenomenon. It was also confirmed that over a quarter of the STDs clients were adolescents between the age 15-19 (mostly boys). HIV/AIDS was reported as a major issue across villages in Machakos district. Cases of people ailing from AIDS complications and the number of HIV/AIDS orphans was high, while for those living with the HIV virus, majority reported to have been infected at the age of 15-25 years. In a visit to the Voluntary, Counseling and Testing centers (VCTs) for HIV in Machakos district, it was clear that the number of adolescents at the age 12-19 presenting themselves for HIV testing was minimal. By the time of this study, compiled reports from all VCTs in the district indicated 2.2% and 3.8% of adolescent boys and girls respectively had tested positive for HIV in the year 2005. More girls than boys were HIV positive.

### **Discussion, Conclusion and Recommendation**

The behavioral characteristics of parents and family members and their processes (monitoring, guiding and supervision) are widely regarded as having particularly

important influences on the sexual behavior of the adolescents (Blum, 2002). Indeed, parental and family members' values, supervision, monitoring, communication and modeling are associated with the sexual behavior of their children. The findings of this study portrayed very minimal interaction between parents/ family members and their children on sexuality matters and this predisposes them to risky sexual endeavors. More over, the study indicated that the mass media and peers have a great deal of influence over each other (Padilla-Walker, 2007).

Indeed, the role played by the peers in the transmission of knowledge, attitudes and practices in relation to intimate aspects of life including love and sex is quite significant. This view is very well highlighted and concurs with this study. The mass media (electronics and print) on the other hand has been reported as predominant source of sexual behavior information by the adolescents as well as key informants in this research. Studies indicate that modern mass media is beset with sexual contents and connotations targeting the youth, and this affects the sexual activity of young people and their beliefs about sex (CSA, 2009). The study also notes that there is the erosion and collapse of traditional institutions and structures that helped to induct the young people to social norms and behavioral expectations.

In conclusion, the study notes that modern Akamba adolescents engage in actual sexual experimentation at relatively tender age, and in an indiscriminate manner. The family and parental supervision, guidance and counseling on sexual matters has become quite minuscule, while the society has to contend with the entrance of ill-advised and ignorant peers who misadvise each other on sexuality matters. This is aggravated by a sexualized mass media. Ignorance and fallacious sexuality knowledge have become the adolescents' Achilles heel upon which their sexuality can be explained. This study opines that the consequences of adolescents'

sexual and reproductive behaviors are a colossal encumber both for the adolescents and the society they live in. Therefore, to save their lives, they need to be adequately prepared and guided in developing their sexuality. The family, as a primary socializer of sexuality should take a leading role in shaping adolescents' sexual and reproductive behaviors, while estranging themselves from socio-cultural and religious barricades that restrain sexuality discussions with adolescents.

In view of above scenario, this study recommends that sexuality discourse should not be made a taboo subject any more. Parents in Machakos district and without must open up, be available and stimulate healthy sex discourse within the home environment. This recommendation is also premised on the understanding that parents and their values are a potent influencing factor to young one's decision about whether or not to have sex. Further, owing to the fact that adolescents and the young ones spent almost over three quarters of their time in school, educational institutions (pre-primary to secondary) come in handy to offer sexuality education. In complementing the family and parents, the education systems in Kenya must vigorously incorporate in their curriculum, facilitate and implement Comprehensive Sexuality education. All school going children and adolescents require a responsible, holistic and medically accurate sexuality education.

## References

- Ahlberg, B. M. Jylkas, E. and Krantz, I.** (2001). "Gendered Construction of Sexual Risks: Implications for safer sex among young people in Kenya and Sweden," *Reproductive Health Matters*, 9(17): 26–36.
- Akong'a, J.** (1986). History and settlement patterns. In were, G.S. and J.Akong'a (Eds.), *Kitui District Socio-Cultural Profile: 26-43*. Nairobi. Ministry of Planning and National Development and IAS, UON.
- Bandura, A.** (1977). *Social Learning Theory*. Eaglewoodcliffs, NJ: Prentice-Hall.
- Barbara, H. and Kirsten, B.** (2002). Parent-Child Communication Resources for Asian/Pacific Islander, Native American, and Latino Families, Advocates for Youth.
- Bledsoe, C. H. and Cohen, B.** (1993). *Social dynamics of adolescent fertility in Sub-Saharan Africa*. Population Dynamics of Sub-Saharan Africa, Washington D.C. National Academy Press.
- Blum, R.W.** (2002). *Mother's influence on Teen Sex: Connections that Promote Postponing Sexual Intercourse*. Minneapolis, MN: Centre for Adolescent Health, University of Minnesota.
- CSA** (2009). *Adolescence in Kenya, The Facts (3<sup>rd</sup> edition)*. Nairobi: CSA
- Dittus, A. J.** (2003). "Parent attitude to adolescent sexual behavior in Lesotho," *African Journal of Reproductive Health*, 17(2): 25–28.
- Government of Kenya (GOK)**. (1989). Kenya Demographic and Health Survey. 1988.
- Government of Kenya (GOK)** (2009). *National Population Census and Housing*. Nairobi: NCPD.
- Greene, M. E.** (1997). "Watering the neighbor's garden Investing in adolescent girls in India" *South and East Asia Regional Working Paper no. 7*. Population Council. New Delhi, India.
- Huberman, B.** (2000). "Raising sexually healthy youth: right, respect, responsibility & parent-child communication," *Transitions*, 15(1): 1–4.
- Jeng, M. S. and Taylor-Thomas, J. T.** (1985). *The persistence of adolescent childbearing and socio-cultural influence: an overview of the Gambian experience*. Prepared for the Seminar on Adolescent Fertility, Lome, Togo, December 2-10, 1985 (Unpublished).
- Kamau J.** (1996). Sexual behaviour in relation to awareness of HIV/AIDS among secondary



- school girls in Nairobi. Masters thesis. Kenya: University of Nairobi.
- Kalule, H.** (1987). Family Life. In were, G., and Akonga, J. (Eds.), *Machakos District Socio-Cultural Profile: 40 – 55*. Nairobi. Ministry of Planning and National Development and IAS, University of Nairobi.
- Mbiti, S. J.** (1969). *African Religion and Philosophy*. Nairobi: Agro Press.
- Mischel, W.** (1973). Toward a Cognitive Social Learning Reconceptualization of Personality. *Psychological Review*, 80, 252-283.
- Ndeti, C.** (1972). *Elements of Kamba life*. Nairobi: East African Publishing House.
- Ocholla-Ayayo, A. B. C. Wekesa, J.M and Ottieno, J. A. M.** (1993). *Adolescent pregnancy and its implications among ethnic groups in Kenya*. International Population Conference, Montreal, International Union for the Scientific Study of Population. Canada.
- Padilla-Walker, L. M.** (2007). Characteristics of mother-child interactions related to adolescents positive values and behaviours. *Journal of Marriage and Family*, 69(3): 675-686.
- Southward, T. E. R.** (1978). *Ecological Methods: Estimating Population Sizes by Mark Recapture and Removal Sampling*. London: Halsted Press.
- Taffa, N., Haimanot, R., Desalegn, S. Tesfaye, A. and Mohamed, K.** (1999). “Do parents and young people communicate on sexual matters? The situation of Family Life Education in rural town in Ethiopia,” *The Ethiopian Journal of Health Development*, 13(3): 205–216.
- Tesfaye, A.Y., Haji, K. B. and Abera, K. T.** (2014). Factors Affecting Parent-Adolescent Discussion on Reproductive Health Issues in Harar, Eastern Ethiopia: A Cross-Sectional Study. *Journal of Environmental and Public Health*. Vol. 2014, 7 pages.
- Wang, B., Li, X. and Stanton, B.** (2007). “Sexual attitudes, pattern of communication, and sexual behavior among unmarried out-of-school youth in China,” *BMC Public Health*, 7 (189).
- Were, M.** (2007). Determinants of teenage pregnancies: the case of Busia District in Kenya. *Economics & Human Biology*, 5(2):322-39.
- WHO.** (1998). *Coming of Age: From Facts to Action for Adolescent Sexual and Reproductive Health*. Geneva: WHO.

# Chimbuko la ‘Sheng’ na Athari Zake kwa Lugha ya Kiswahili: Mpangilio wa Kifani, Chuo Kikuu cha Maseno

By

Mary Lukamika<sup>1\*</sup>

*1; Chuo Kikuu cha Maseno, Kenya.*

*\*Corresponding author: [kibigomary@gmail.com](mailto:kibigomary@gmail.com)*

---

## Abstract

This paper discusses the origin of ‘Sheng’ and its usage in higher learning institutions; A case study of Maseno University. It also focuses on the historical development of ‘Sheng’ and its journey to counter Kiswahili language. Language is a people’s possession. They are activities of the society that grow, move and change depending on the changes of people within their gatherings, just like it does. Though some people have advocated for the growth of ‘Sheng’ as a societal growth indicator in Kenya, others including scholars and other stakeholders have refuted it and feel that its spread hinders the growth of standard Kiswahili in higher learning institutions, especially the Universities. In essence, some scholars believe that ‘Sheng’ should be left to musicians, the youth and those who are semi-illiterate in order to ease their communication. However, ‘Sheng’ affects more Kiswahili language than it does to English because its grammar is similar to that of Kiswahili standard. Therefore, the paper surveys its origin and recommends strategies to counter its fast growth. Its adverse on higher learning should be addressed accordingly.

---

## ***Ikisiri***

Makala haya yanajadili chimbuko la Sheng’ na athari zake kwa viwango vya juu vya elimu: Mpangilio wa kifani, Chuo Kikuu cha Maseno, Kenya. Aidha, yanaangazia historia na maendeleo ya lugha ya Sheng’ na juhudi zake katika kuitinga lugha ya Kiswahili, amali ya Wakenya. Kuna matendo katika jamii ambayo hukua, husonga na kubadilika kutegemea mazingira na lugha ni mojawapo. Ingawa baadhi ya watu hupigia upatu ukuaji wa lugha ya Sheng’ kama kielekezi cha ukuaji wa jamii nchini Kenya. Wanaonelea kuwa muda unapoendelea, lugha ya Sheng’ itaathiri vibaya ukuaji wa Kiswahili Sanifu katika viwango vya juu vya elimu hususan Vyuo Vikuu. Kwa upande mwingine, wanazuo

wengine wanaamini kuwa lugha ya Sheng’ inafaa kuachiwa wanamuziki, vijana na wale wasioelimika ili kurahisisha mawasiliano yao. Hata hivyo, ingawa Sheng’ inaonekana kuwa mchanganyiko wa lugha mbili, imeathiri kwa kiasi kikubwa lugha ya Kiswahili, fahari yetu ya kitaifa ikilinganishwa na Kiingereza. Hii ni kwa sababu maneno machache yamekopwa kutoka kwa lugha ya Kiingereza ili kuwasilisha au kukamilisha ujumbe. Usampulishaji wa viko ulitumiwa pamoja na usampulishaji wa kimfumo ili kutupatia sampuli faafu ya wanafunzi wa Kiswahili wa Chuo Kikuu cha Maseno. Sampuli hizi zilikusanywa baina ya mwezi wa Machi na Aprili, 2013. Data zilikusanywa kwa kutumia dodoso na hojaji. Makala haya yanaangazia chimbuko la

Sheng', athari zake na kupendekeza hatua za kuizuia kutinga lugha ya Kiswahili katika viwango vya juu vya elimu, Chuo Kikuu cha Maseno kikitumika kama kifani.

### *Utangulizi*

Kila jamii lugha inayokua hukopa msamiati kutoka kwa jamii mbalimbali ambazo hutagusana nazo, ni kutokana na hali hii ambapo lugha nyingi za kimataifa ziliweza kupata uchangamano wake, (Chimerah, 1995). Kulingana na Momanyi (2001), watafiti wengi wameibua nadharia anuwai kuhusu chimbuko la Sheng' (Ogechi, 2005; Githiora, 2002; Abdulaziz na Osinde, 1997; Spyropoulos, 1987). Hata hivyo, wote wanakubaliana kuwa Sheng' iliibuka katika mitaa ya mabanda ya Eastlands jijini Nairobi. Tukiangazia Spyropoulos kwa mfano, anadai kuwa Sheng' ilibuniwa pindi tu Kenya ilipopata uhuru mnamo mwaka wa 1963. Kwa upande mwingine, lugha ya Kiswahili ilisanifishwa mnamo mwaka wa 1930 katika karne ya ishirini ili kuwa lahaja moja kwa minajili ya mawasiliano katika Afrika Mashariki, kitamaduni, kielimu na maendeleo ya siasa na jamii. Mazrui na Mazrui (1995) wanasema kwamba Kiswahili ndiyo lugha ya kimataifa zaidi ya nyingine zote za Afrika. Ijapo asili ya Kiswahili ni upwa wa Afrika Mashariki, lugha hii imepata ufanisi kiasi cha kuweza kutumika katika utandawazi na maendeleo ya teknolojia na mawasiliano kwa jumla, kwani kuna uhusiano wa kufaana baina ya lugha ya Kiswahili na vyombo vya habari, (Mohochi 2002). Anavyodokeza Momanyi (2001), lugha hii iliyosanifishwa ndiyo inayotarajiwa wanafunzi wajifunze katika viwango vyote vya elimu ili kuwasiliana na umma kwa jumla. Aidha, lugha hii hutumika katika vitabu na nyenzo za elimu, shuleni, bungeni na hata katika utawala. Isitoshe, lugha ya Kiswahili haina ukabila. Hata hivyo, lugha za Kiswahili na Kiingereza zimepigwa vikali na wimbi hili la Sheng' linalowahusisha kwa kiasi kikubwa wazungumzaji vijana.

### *Chimbuko la Sheng'*

Sheng' ni kilugha cha mseto kinachotumia maneno ya Kiswahili, Kiingereza na lugha za kienyeji kama Dholuo, Kikuyu na Kiluhya pamoja. Ingawa Sheng' huchanganya maneno kutoka lugha mbalimbali, inaaminika kuwa asili ya neno lenyewe ni, "Sh-" kutoka kwa neno "Swahili" na "-eng" kutoka kwa neno "English". Aidha, Sheng' ni lugha inayokaribia kufanana na sarufi ya Kiswahili, kwa mfano:

- a) "Omosh amekick boli" yaani "Omondi ameupiga mpira".
- b) "Buda atakam kesho" yaani "Baba atakuja kesho".

Muundo huu wa sarufi ni wa; Kiima + kitenzi +yambwa (Echessa, 1990).

Kwa mujibu wa Spyropoulos (1987), chanzo cha kilugha cha Sheng' ni machokoraa wa Nairobi. Anaongezea kuwa, ingawa hivyo, Sheng' ilivumbuliwa na wakazi wa zamani wa Nairobi baada ya Uhuru mnamo mwaka wa 1963, miongoni mwao walikuwa wafanyakazi na waliokuwa WanaMauMau pamoja na jamaa zao, walioacha shule na wengine kama hao. Inasemekana kuwa waliotumia Sheng' kwa wingi walikuwa ni wanabiashara wa vinyago, wapigaji viatu rangi na utingo miongoni mwa wengine.

Wataalam wengine wanadai kuwa maandishi ya kwanza kabisa kuhusu Sheng' yalichapishwa katika magazeti ya *Daily Nation* ya mwezi wa Februari na Machi mwaka wa 1984. Aidha, inaaminika kwamba lugha hii ilianza kunenwa na vijana wa maeneo ya Eastlands katika mitaa ya mabanda ya jiji la Nairobi, halafu ikaenea katika miji mingine kote nchini Kenya.

Sheng' iliibuka kama lugha ya siri miongoni mwa vijana. Ilihusisha mseto wa maneno ya Kiswahili na Kiingereza. Hata hivyo, baada ya muda usio mrefu, vijana waliweza kuifanya lugha hii kunoga kwa kuongezea maneno ya lugha za kienyeji nchini Kenya, (Momanyi 2001). Ifuatayo ni mifano tuliyoidondoa kutoka kwa wanafunzi wa Kiswahili wa Chuo Kikuu cha Maseno;

- a) Kiruru... 'pombe' ( Gikuyu...kiruru)
- b) Tunaendanga... 'huwa tunaenda'(<Waluhya ...hali ya kwenda kila mara)
- c) Otheroo... 'githeri' (<Gikuyu...githeri)
- d) Shuu... 'viatu' (<English...shoes)
- e) Manya... 'jua'(<Mijikenda)
- f) Daso... 'soda' (Pig Latin...mbinu inayotumiwa na Sheng' kusoma silabi kutoka mbele)
- g) Buda... 'baba'(<Hindi... mwanaume mzee)

Mifano hii inaonyesha kule kukopa kutoka lugha mbalimbali na kuzua mikondo mbalimbali katika Sheng' (Githiora, 2002).

Hebu tutazame kwa ufupi jinsi maneno yanavyoundwa katika Sheng':

a) *Ubadilishaji wa silabi*

Mbinu hii hutumika ili kuleta upekee wa neno. Kulingana na Ngesa (2002), Sheng' hubadili neno ili liwe jipya na tofauti na neno asilia na kusitiri maana. Kwa mfano; neno **kadi** huwa **dika** katika Sheng'.

b) *Truncation (ufupishaji)*

Katika mbinu hii, Sheng' huyapa maneno yaliyokopwa sifa za Kibantu kwa kuangazia silabi za mwanzo au mwisho. Kwa mfano; finje linalotokana na neno **fifty** la Kiingereza.

c) *Coining (ubunifu)*

Sheng' hutumia mbinu hii kuunda neno ila si kwa misingi ya neno lililopo. Kwa mfano; Bling Bling...chain...mkufu. Mboch...househelp...kijakazi / yaya Hata hivyo, ni vigumu kujua lugha - maana ya maneno katika uundaji.

d) *Ukopaji*

Sheng' hutumia mbinu hii kutoa leksia yake katika lugha iliyopo. Kwa mfano; Ku-shut...kupiga risasi...shoot (<English) Kunyita...kushika/kuelewa ...to understand (<Gikuyu).

Mifano hii inaonyesha utata wa lugha ya Sheng'. Ndiposa Momanyi (2009)

anachangia kwa kusema kuwa wanafunzi wa viwango vya chini hususan shule za msingi huweza kuzungumza na kuandika Kiswahili sanifu lakini wanapoingia katika shule za upili na hata Vyu Vikiu, kiwango chao cha mawasiliano katika Kiswahili sanifu hushuka kwa kiasi kikubwa kwa vile huwa wanatumia Sheng' kwa wingi.

*Athari za Sheng'*

Makala haya yanaegemea kwa utafiti tulioufanya katika Chuo Kikuu cha Maseno baina ya mwezi wa Machi na Aprili, 2013. Utafiti wetu unaonyesha wazi kuwa hakika lugha ya Sheng' ipo, ni hai na inahusishwa na vijana wanaodai kuwa wamekengeuka kutokana na usasa. Hata hivyo, nitaongezea maoni ambayo hayakinzani na maelezo yaliyopo kuhusu Sheng' ila yanafidia yaliyochapishwa na na kujadiliwa kuhusu hali ya Sheng' katika enzi za kisasa, hususan katika Vyu Vikiu. Kwanza kabisa, utafiti wetu ulitambua kuwa, kuna aina tofauti za Sheng' kutegemea kikundi fulani cha vijana. Hili lilikuwa jambo la muhimu kwetu kwa sababu, utafiti wetu uliwalenga wanafunzi wa Kiswahili wa Chuo Kikuu cha Maseno kuanzia mwaka wa kwanza hadi wa nne. Hivyo basi, matokeo ya dodoso na hojaji yalibainisha wazi kuwa Sheng' iliyoibuka katika mitaa ya mabanda jijini Nairobi, imebadilika na kubuniwa upya kwa vile wanafunzi hao walidai walikuwa na nia ya kuendelea kuwasiliana kisiri ili watu wengine wasielewe mazungumzo yao. Utafiti wetu ulibaini kuwa maneno mengi ya Sheng' si ya kudumu, bali hutumiwa kwa muda mfupi kisha yanabadilishwa punde tu inapogunduliwa kuwa watu wengi wameyafahamu. Kwa hivyo, utafiti wetu ulitambua kuwa Sheng' ni kilugha cha mpito. Mifano ifuatayo ilidondolewa kutoka kwa wanafunzi wa Kiswahili wa Chuo Kikuu cha Maseno:

- a) Punch, kobole, ngovo, hamsa... 'sarafu ya shilingi tano'.
- b) Makopaa, karao... 'polisi'
- c) Buda, mzaee, mdoss, mbuyu, fadhee au fathee... 'baba'.

- d) Manzi, dem, madamosi, mresh, msupa au mxupa, mlosho... 'msichana'.  
 e) Nitakushow, nitakutel, nitakuinfo,..'nitakuambia' au 'nitakujulisha'.

Mifano hii inaonyesha kule kubadilikabadilika kwa lugha ya Sheng' mithili ya lumbwi kama ilivyobainika miongoni mwa wanafunzi hao wa Kiswahili wa Chuo Kikuu cha Maseno.

Ndiposa Mazrui (1995) anaeleza kuwa Sheng' ni lugha ya mitaa yenye misingi yake katika uhamishaji msimbo toka lugha mbili; Kiingereza na Kiswahili wanayotumia vijana. Anaongezea kuwa vijana wa siku hizi katika sehemu za mashinani wanatumia lugha hii hii ya Sheng' ambayo ilikuwa Sheng' ya enzi zao. Aidha, elementi zinazoibuka huishia kutimiza sheria za mofo-sintaksia za Kiswahili kinyume na katika Kiingereza kama vile; relax, come, elapse n.k. Hivyo basi, kutokana na Mazrui (mtaje), Sheng, huchukua cheo cha hali na nafsi katika Kiswahili kwa mfano; ali-come, ana-come, ame –come na atacome.

Utafiti huu ulitoa mchango mkubwa kwa dhana ya Sheng' kutokana na matokeo ya uchanganuzi wa dodoso na hojaji. Wanafunzi hao wa Kiswahili wa Chuo Kikuu cha Maseno walikubaliana na utafiti wa kiisimu na kiisimujamii unaoonyesha kuwa kuzuka kwa Sheng' kulichangiwa sana na ile hali ya vijana kuweza kutumia lugha rahisi (sahili) ya mawasiliano isiyowafunga katika kuzingatia sheria nyingi za kisarufi. Baadhi ya wanafunzi hao walidai kuwa, wao hutumia Sheng' katika mawasiliano kwa wingi kwa vile ni njia rahisi ya kuwasiliana kwa haraka kwa kutumia ufupishaji na ubadilishaji wa silabi za neno, kwa mfano:

- Maspidi... 'haraka sana' (very fast)
- Daro... 'darasa' (classroom)
- Hosi... 'hospitali'(hospital)
- Hedi... 'mwalimu mkuu' (headmaster/ headteacher)
- Vifit... 'vizuri sana' (very good)
- Gava... 'serikali' (government)

Isitoshe, utafiti huu ulibaini kuwa lugha ya Sheng' ina msukumo mkubwa na inakita mizizi kimawasiliano kwa vile vijana kutoka makabila mbalimbali walitaka kujihusisha au kujitambulisha kijamii kama kikundi cha watu wa kisasa waliostaarabika, licha ya kwamba waliichukua kozi ya kujifunza Kiswahili iliyowahitaji kuwasiliana kwa kutumia Kiswahili sanifu. Ingawa hivyo, baadhi ya wataalam wanapinga vikali kauli hii. Asemavyo (Echessa, 1990: 53), "kilugha cha Sheng' ni muhimu hasa kwa vijana na watu wasiokuwa na elimu ya kutosha kwa sababu, hali ya kubadili na kuchanganya Kiingereza na Kiswahili wanapokumbwa na tatizo la lugha huwarahisishia mawasiliano".

Sheng' inasemekana kuenea mithili ya moto wa jangwani katika lugha za Kiswahili na Kiingereza miongoni mwa lugha nyingine. Hata hivyo, utafiti wetu ulibaini kuwa Sheng' huathiri zaidi Kiswahili kuliko Kiingereza kwa sababu ya matumizi ya sarufi inayofanana na Kiswahili. Jambo hili lilikuwa kizungumkuti kwa vile liliwafanya baadhi ya wanafunzi wa Kiswahili wa Chuo Kikuu cha Maseno kukanganyikiwa kwa sababu ya uzoefu wa kimatumizi, kwa mfano; Matumizi ya neno kama 'buda'kuashiria *baba* kisheng'ilhali *Kamusi ya Kiswahili Sanifu* (2004) inaeleza **buda** kama;

- Mwanamume mzee sana.
- Mtu asiye na meno; kibogoyo.
- Ndovu mzee asiye kuwa na pembe.

Hali hii iliathiri maendeleo ya Kiswahili Sanifu kwa njia hasi na mitindo ya Sheng' kama anavyosema Momanyi (2001: 87):

"...lugha ya Kiswahili imefika kwenye njia panda kwani idadi kubwa ya watu hawawezi kupambanua matumizi bora ya lugha ni yapi."

Utafiti huu ulibaini kuwa kilugha cha Sheng' ni tishio kali kwa Kiswahili Sanifu kwa vile kina umuhimu wake kimawasiliano. Wanafunzi hao walisema kuwa walipata changamoto ya kupata kejeli kutoka kwa marafiki zao ambao waliidunisha lugha ya

Kiswahili na kuiona kuwa duni. Hata hivyo, isimu jamii ni muhimu kwa sababu huchunguza umuhimu ambao utamaduni huipa lugha katika mawasiliano miongoni mwa wanajamii (Mathooko, 2007). Katika muktadha huu, Sheng' ilikuwa changamoto kwa vile iliwapa baadhi ya wanafunzi hao uhuru wa kuwasiliana bila kuzingatia kaida za kisarufi walipokuwa wakirekodiwa huku wakisailiwa (dodoso).

Maoni tuliyoyapata kutoka kwa watafitiwa kuhusu Sheng' yalituelekeza katika athari chanya na hasi. Kwa upande mmoja kuna baadhi ya watafitiwa waliodai kuwa Sheng' inaathiri na kutinga maendeleo ya Kiswahili Sanifu na hivyo kulegeza kukua kwake katika elimu. Walionelea kuwa Sheng' ilikuwa mbioni kuharibu lugha ya wanafunzi. Aidha, wanafunzi wa mwaka wa tatu na nne walionelea kuwa lugha ya Sheng' haikuwa inafaa iwachiwe nafasi kuzagaa. Kwa upande mwingine, watafitiwa wengine walionelea kuwa Sheng' inafaa kupigiwa upatu ienee kwani ni lugha ya vijana yenye mvuto na ya kusitiri siri katika maongezi. Aidha, ni lugha inayowafanya vijana kuonekana wamestaarabika. Vilevile, wanafunzi wa mwaka wa kwanza na pili walidai kuwa Sheng' **iliwabamba** yaani iliwafurahisha.

### **Mapendekezo**

Mapendekezo yafuatayo yaliweza kutolewa ili kuendeleza Kiswahili na kuzuia lugha ya Sheng' kuenea nchini Kenya:

Kwanza kabisa, vyama vya Kiswahili vinavyoundwa shuleni, vyuoni, magazetini na kwingineko vishirikiane na kujumuika na washikadau wote ili kutafuta mbinu mwafaka za kuyaboresha mafunzo na matumizi bora ya lugha hii nchini Kenya. Wanaohusika ni pamoja na wahadhiri na walimu, watangazaji wa runinga na redio, washapishaji majarida, magazeti na vitabu, wasimamizi wa shule na Vyuho na watumishi wa serikali.

Pili, serikali ishiriki kwa hali na mali katika maandalizi ya vikao vya Kiswahili kama vile warsha, seminaa na makongamano na

isaidie katika kuyatekeleza maazimio yanayopitishwa. Haya yanaweza kuwa kwa njia ya kuifadhili miradi inayokusudiwa kuendeleza Kiswahili.

Tatu, Taasisi ya Uchunguzi wa Kiswahili ianzishwe katika Vyuho Vikuu vyote.

Nne, kamati ya wasomi na wanazuo wa Kiswahili kutoka Afrika Mashariki, kati au Afrika yote iundwe ili kuweza kusanifisha istilahi. Aidha, kamati hii iweze kuchukua jukumu la kuandaa pamoja mikakati ya kukiendeleza Kiswahili.

Mwisho, makamusi zaidi yaundwe yaliyo na msamiati unaobainisha maneno ya Sheng' na vile yanavyoingiliana na maneno ya Kiswahili Sanifu.

### **Hitimisho**

Ingawa matokeo ya utafiti wetu yaliegemea katika sampuli ya wanafunzi wa Kiswahili wa Chuo Kikuu cha Maseno kuanzia mwaka wa kwanza hadi wa nne, hiki kilikuwa ni Chuo Kikuu kiwakilishi cha viwango vya juu vya elimu. Imetulazimu kuhitimisha kwa kusema kuwa Sheng' ni lugha hai. Hata hivyo, wanafunzi wa miaka ya chini hususan mwaka wa kwanza hutumia Sheng' kwa kiasi kikubwa lakini wanapoendelea kukomaa kiakili na kukua, huyapunguza mashiko ya Sheng' na kutumia Kiswahili Sanifu. Ingawa hivyo, Sheng' pia ina umuhimu kiisimujamii. Aidha, si lugha ya mpito inavyodaiwa na wengine.

### **Marejeleo**

**Abdulaziz, M. H. na Osinde, K.** (1997).

Sheng' and English: Development of Mixed codes among the urban youth in Kenya. *International Journal the Sociology of Language*. Berlin: Allemagne.

**Echessa, P. G.** (1990). "A Study of the Word Structure and Processes involved in Word Formation in Sheng": A Case Study of Eastlands Area of Nairobi." M. A. thesis, Kenyatta University.

**Githiora, C.** (2002). *Sheng': Peer language, Swahili dialect or emerging Creole?* London Taylor and Amp; Francis Ltd.

- Mathooko, M. P.** (2007). *Isimujamii: Misingi na Nadharia*. Nairobi: Nigua Books.
- Mazrui, A. A. na Mazrui, A. M.** (1995). *Swahili State and Society: The Political Economy of an African Language*. Nairobi: E.A.E.P.
- Mohochi, E. S.** (2002). Teknolojia ya Mawasiliano na Nafasi ya Kiswahili Ulimwenguni katika Utafiti wa Kiswahili. (mhr.) Inyani Simala K.Eldoret: Moi University Press.
- Momanyi, C.** (2009). The effect of Sheng' in the Teaching of Kiswahili in Kenyan Schools. *The Journal of African Studies*, Vol.2 no. 8, March 2009. Nairobi: Kenyatta University Press.
- Momanyi, C.** (2001). "Matumizi ya Kiswahili Katika Njia Panda: Mtazamo wa Kiisimu – Jamii" Katika Kiswahili". *A tool for Development-The Multidisciplinary Approach*-Eldoret: Moi University Press.
- Ngesa, M.** (2000). 'And Sheng' lives...' In the Standard Profile Magazine, February 16-22 2002; 17-18. Nairobi, Kenya.
- Syropoulos, M.** (1987). *Sheng: Some preliminary investigations into a recently emerged Nairobi Street language*. In *Journal of the Anthropological Society of Oxford* 18(1): 125-136.
- TUKI.** (2004). *Kamusi ya Kiswahili Sanifu. Toleo la Pili*. Nairobi: Oxford University Press.

# The Question of Elitism, Medium and Audience in African Literature: Examples from Kiswahili Short Story

By

MCOnyango Owen Ouko<sup>1\*</sup>

*1; Department of Kiswahili and Other African Languages, Maseno University*

*\*Corresponding Author: [omconyango@yahoo.com](mailto:omconyango@yahoo.com)*

---

## Abstract

Since the Makerere Conference of 1962, the question of what is 'African Literature' has remained unresolved. To a large extent a great number of scholars led by Ngugi reduced the whole question to that of language. This paper by drawing examples from the Kiswahili short story suggests a wider range of aspects of literature to be considered in the decolonization of African Literature.

**Key words:** African literature, Kiswahili, literary models

---

## Introduction

The colonial experience in Africa left an imprint of cultural dualism that has generated a spirited search for consonance in African Literature. The main question then, when Africa was just beginning to emerge from the shell of colonial control, was why the African writer had to continue writing in English. The question spread quickly to non-English speaking countries and was asked in Francophone and Lusophone areas on the continent.

For decades now Ngugi wa Thiong'o has led the onslaught against English as a language for the expression of African literature. He has had allies. Achebe on the other hand has been seen as an icon in African literature that defends the use of a colonial language - English - in the rendition of African literature. And for all those decades energy has been over-expended on the question of whether to or not to use European languages

in the writing and general presentation of African literature.

This paper shifts the centre of debate from the search of relevance in and of literature in European (colonial) languages and proposes a re-entry into the indigenous linguistic space in search of authenticity. This paper proposes that it has been so long out there and there is need to examine African language literatures which have over the years co-existed with African literature in European languages. This intra-examination draws examples from Kiswahili literature - from Kiswahili short story (*hadithi fupi*) in particular.

## The Issues at Stake

Jahn (1961) states in *Muntu* that, "Through the **influence** of Europe, it is believed, Africa is adapting itself, giving up her traditions and adopting **foreign** ideas, methods of organization. The time of transition, whether



short or long, is thought to be a time of **crisis** which will confront all Africans with the decision to either accept modern civilization and survive, or to perish with their own traditions,.... all are agreed that a fully **Europeanized Africa** will be the end product of the process (Jahn, 1961).

Of course Jahn is aware of the Japanese example to the world: appropriation of modern technology and modern forms of organization and grafting it to the traditional **culture** (*Ibid* 12). From the foregoing one would not know from whence this European influence is to be traced. However, probably, one need not look very far: In his next book, *Neo-African Literature: A History of Black Writing* Jahn (1968), reports that Alfonso Alvares is the first author of African descent he had discovered that wrote literature in a **European language** in the seventeenth century with extant works of between 1613 and 1639 (Jahn, 1968).

Sadly, Jahn says although Alfonso Alvares was half black (the mother having been black), nothing in the style or content points to the African mother! Had it not been his quarrel with another poet who wrote back insulting poetry nothing would have been known of his African origin, even from his writings!

Jahn goes on to state that the language in which an author writes shows his spiritual home and his sphere of action (Jahn, 1965). In *Song of Lawino* p'Bitek (1966) writes:

You insult me  
You laugh at me  
You say I do not know the letter A  
Because I have **not gone to school**

My clansmen I cry  
Listen to my voice  
The insults of my man  
Are painful beyond bearing

My husband abuses me together with  
my parents  
He says terrible things about my  
mother

And I am so ashamed  
He abuses me in **English**

He says my eyes are dead  
And I **cannot read**,  
He says my ears are blocked  
And cannot hear a single **foreign**  
word

My husband's tongue  
Is bitter like the roots of *lyono* lily,  
It is hot like the penis of a bee,  
Like the sting of *kalang*! (*Song of Lawino*: pp14-16) (emphasis belongs to this paper)

Two recent features in newspapers in Kenya are also of interest here: In one (The Standard June 21, 2014), Peter Amuka, a professor of literature at Moi University, Kenya recalls his great teachers in the Department of Literature at the University of Nairobi in early 1970s. He remembers Author Kemoli **who sang** and p'Bitek, **who sang and laughed**. In the other article, Wanjiku Kabira, a professor of literature at the University of Nairobi, also remembers p'Bitek as their **oral literature** lecturer who refused to record their marks because he argued it was a course in oral literature – **no writing** (The Standard 24<sup>th</sup> 2014).

These are the issues for thought in this paper: (a) **Language** for African Literature and that is why I quote Lawino castigating her husband for abusing her in a foreign language, English and for claiming her ears are dead just because she does not hear a single foreign word; (b) The **elitism** alluded to by Lawino in referring to the arrogance of her husband; (c) The **differentiation** of the **African audience** by European education; (d) The pain of Africa being lost in the labyrinth of European **culture**; (d) Finally, which way for African literature? In what **genre** should African literature be presented: In song like Kemoli and p'Bitek?

### **The Question of Language Choice**

At the Makerere conference of 1962, Ngugi (1981) reports that it was, 'A Conference of African Writers of English Expression'. The conference concentrated on extracts from works in English. This left out Shabaan Robert who was by far, indeed by then, a great poet with several works of poetry and prose in Kiswahili. Chief Fagunwa who had written widely in Yoruba could not attend either. This then brought the question of, 'What is African Literature?' Since then, the related questions namely, Is African Literature that literature written by Africans? Is it literature written in African languages? Why exclude literature in Zulu, Kiswahili, Amharic and other African languages? Have this been recurring over and over again?

Ngugi took a stand especially in 1981 with the publication of *Decolonizing the Mind: The Politics of Language in African Literature* never again to write in English. He swore to write in Gikuyu and Kiswahili. He made a choice. His choice, seemingly in response to the Makerere questions, which for literature to be correctly titled 'African literature' it must be in an African language. Ngugi chose Gikuyu and Kiswahili. In this paper the argument is that here lies the problem. Does turning to an African language *per se* make any literature African?

Drawing from examples from Kiswahili short story hereinafter referred to in translation as *hadithi fupi*, the argument in this paper is that code-switching to an African language does not automatically lead to a literature that is all-round African. The main hypothesis is that for a literature to be English, French, Arabic or African there arises a need for a more comprehensive evaluation that goes beyond the linguistic paradigm.

### **Literary modes of Existence**

Welleck and Warren (1949) argue that literature exists by depending of a variety of modes of existence or ontological sites. To them language would just be one mode of existence since literature is a verbal art. Apart from language, there is the 'writer',

'critic', 'audience', 'theory', 'culture' and so on. Chinweizu and Co. (1983), contend that the 'nationality' and 'consciousness' also add to the list.

It therefore would follow, that the classification and the naming of a body of literature as African would have to regard all aspects of the given literature. The debate of the 1980s pitying Hassan Mwalimu Mbega and his allies against the free verse poets led by Kezilahabi is a case in point. Kezilahabi's *Kichomi* was published in 1974 but it is Kithaka wa Mberia and others who in 1980s and 1990s that re-ignited the debate on what form Kiswahili poetry should take. Ibrahim Noor Sharriff published his book, *Tugo Zetu* in 1988 in defense of the traditional form of *shairi* (poem). In the debate in question the issue was never about the language. The poetry, either by Kithaka Mberia or Kezilahabi on the one hand and Shariff and Mwalimu Mbega on the other, was expressed in Kiswahili language. The issue was, 'What should be the form of a poem in Kiswahili?'

The Kiswahili novel has also been subjected to some debate, not on the question of language. Phillipson (1988) for example discusses the place of the novel in Kiswahili from the point of view of content or theme. In this case the Swahili novel is questioned based on another mode existence which is 'theme'. The issue pursued by Phillipson is on the whole question of what should be the concern of a novel in Kiswahili since it is at times viewed as disseminating bourgeois mannerisms.

### **The short story (*hadithi fupi*) in Kiswahili**

In view of the postulations of Welleck and Warren (1949) and Chinweizu and others (1983), the modes of existence of *hadithi fupi* go beyond language as a mode. Kiswahili is an East African language that has been in existence since 500 AD and possibly much earlier (Mazrui and Mazrui, 1995). It is indeed a *lingua franca* in East Africa from Somalia in the north to the Comoro Islands in the South. Chacha – Nyaigotti (1994) and

Chriaglidin and others (1977) have done superb work to place the language among the coastal Africans. The question of language is thus not in dispute.

Madumulah (1995) and Bertoncini *et al* (2009) for example do not debate the language question in regard to *hadithi fupi*. The contention is on the *hadithi fupi* form as a new genre within the body of Kiswahili literature. The newness then raises the question of how *hadithi fupi* fits within the continuity of Kiswahili literature particularly in regard to 'literary tradition' as yet another mode of literary existence. In this paper the aspects of existence of *hadithi fupi* selected for consideration are: theory, structure, writer, critic and audience. It is argued that:

- The theory of *hadithi fupi* matches one on one that of the short story in English
- The structures also match
- The writer and the critic have sensibilities arising from their western education
- The audience of *hadithi fupi* is left differentiated in regard to level of education and whether one is in that group that interacts with the new genres.
- The *hadithi fupi* as a form, due to the aforementioned, is as elitist as literature in European languages for the same reasons that such literatures became elitist.

### Theory

The late Msokile is the only Kiswahili scholar who has given *hadithi fupi* a book-length treatment in his book *Misingi ya Hadithi Fupi* of 1992. Mbatiah in the introduction of his collection of *Hadithi Fupi* called *Mwendawazimu na Hadithi Nyingine* of 2000 also offers a concrete explanation of the major features of *Hadithi Fupi*. There are also articles in a variety of journals from which a standpoint as to what a short story in Kiswahili is can be taken. From a selection of these the major components of the theory of *Hadithi Fupi* can be discerned.

In all the presentations of the theory of *Hadithi Fupi* reference is made to the theory of the American and European short story. The major components of the theory of *Hadithi fupi* can therefore be treated by grouping them into two; those points of agreement between the theory of the short story in English and the theory of *hadithi fupi* and secondly, those areas that make the *hadithi fupi* theory specific to Kiswahili literature.

Both Mbatiah (2000) and Msokile (1992) give recognition to Edgar Allan Poe and other short story theorists of the American and European orientation (for example Mbatiah on Foster and V. Shaw, and Msokile on Esenwein). In the end theoretical features emerge that create proximity between the western short stories and *hadithi fupi*. So that the characteristics of the short story in English, namely, '**Work of Art, Single Effect, Unity of Effect, Pre-conceived Effect, Brevity, Contrast from the Novel, Contrast from the Folk Tale, Single Point of View, and Social Truth**', re-emerge in the theorization of *hadithi fupi*.

The theorists of *hadithi fupi* recognize the characteristics as propounded by Poe, Esenwein and other theorists of the short story in English and agree with them (Mbatiah, 2000; Msokile, 1992).

Msokile therefore summarizes those characteristics thus:

- *Hadithi fupi* is a **work of art**
- *Hadithi fupi* should be a **single event**.
- A single incident be presented from **one** or two characters.
- The single incident be presented **briefly**.
- *Hadithi fupi* should be a reflection of a **real life** but should not be literal and should go by artistic exaggerations of the natural.
- *Hadithi fupi* should be based on some **confined** setting.
- That *hadithi fupi* should exhibit internal **unity**.

Mbatiah (2000) too accepts Poe's propositions and the theories of *hadithi fupi* and short story in English find points of convergence and to Mbatiah, as it is to Poe, *hadithi fupi* should be:

- A presentation of a **single aspect of life**.
- Short or **brief**.
- A presentation of **one point of view**.
- Of **few characters** who are **not fully developed**.
- A **realistic** depiction of **society**.
- Of **totality** or **unity of effect**.
- Of words all aimed at attaining the **pre-conceived effect**.

### Structure

There are also similarities between the structure of *hadithi fupi* and structure of the short story. The similarities are striking in that they present a structural proximity between *hadithi fupi* and the short story in English that can only be a result of conscious adaptation. The finding in studying the structure of *hadithi fupi* is that its components relate on a one to one basis with those of the short story in English. Concepts on structure in Kiswahili, among them *mwanzo*, *kati*, *mwisho*, *mgogoro* and *kipeo* for instance, find a directly related English version, **beginning**, **middle**, **end**, **conflict** and **climax** respectively. There is therefore, evidence of influence from the short story in English on the *hadithi fupi* form in Kiswahili.

Although some Kiswahili *hadithi fupi* critics argue against the count of words as a definitional marker for *hadithi fupi*, and although the reason that the word-count is wrong because of the linguistic differences between Kiswahili and English, nonetheless there is a general agreement that the **economy of words** is both a feature of *hadithi fupi* as much as it is of the short story in English.

The general diagrammatic representation of the structure of *hadithi fupi* also agrees with that of the short story in English. The rise of tempo after the **beginning** of a short story,

with the **conflict** raising the tempo to a **climax** and then the drop to the **denouement** and to the story's **end** is also the structural diagrammatic picture presented by *hadithi fupi*.

The rule on **brevity** in the short story in English with its aspects of the control is not only the number of words, but also control on **time span** and **number of pages** has permeated *hadithi fupi*. This element of brevity also dictates the number of themes that one story can handle, as well as the number of characters that can be used to develop the selected theme(s). Brevity has therefore confined the short story to one major **theme**, **single event** and very **few characters** per story. These structural rules are to be found in the *hadithi fupi* form as well.

The epistolary form of the short story in English is also to be found in the modern *hadithi fupi*. This is a feature that can only be best represented in writing and is therefore quite possible in *hadithi fupi*, while the oral traditional African story in general and even the Swahili *ngano* in particular, in which epistles are not to be found even in written collections.

### Writer, Critic and Audience

Further the **writer** of *hadithi fupi* exhibits the characteristics of the writer of the short story in English or in any other European language. He is educated, has most likely read (even if not studied) literature in English and in the case of *hadithi fupi* the majority are graduates. In fact a good number work at the university in East Africa, elsewhere in Africa and abroad. This group of writers writes what would be called, in Ohly's (1992) or Gromov's (1996) classification, serious literature as opposed to popular or pulp literature. Elitism is part of this group of writers by virtue of the level of literature they venture into. According to Ohly (1992) he must be distinguished from the traditional Swahili or African story-teller who told stories meant for all. His abilities

depend on his level of education and writing skills.

There is the other group of writers who write *hadithi fupi* for Kiswahili newspapers especially in the case of Tanzania. As was stated earlier sometimes *hadithi fupi* are found in newspapers that are worth publishing in anthologies in book form. Once in a while the stories happen to be from highly trained university academics. However, by and large the newspaper *hadithi fupi* writer and his or her story is classified as entertainment literature and not worth serious attention (Senkoro 1979/80). This dismissive classification of a whole lot of newspaper *hadithi fupi* goes a long way to strengthen the argument of elitism among the writers of modern *hadithi fupi*.

The **critic** of *hadithi fupi* is not different from the writer. In many cases it was found they are the same group of people. The writers are the same that write introductions with guidelines on the writing and criticism of *hadithi fupi*. The *hadithi fupi* critic is therefore also highly educated and this leads to his or her locking out works s/he does not consider to be of the level of serious literature. The elitist stance of the practitioners in the *hadithi fupi* genre is promoted first and foremost by the instinct of the critic. Indeed it is the critic or the critical instinct even in a writer that locks out works that would otherwise form part of a literary tradition at a community, national or regional level.

The theoretical and structural influences of the short story in English that have affected the perception of *hadithi fupi* are works of criticism. In any case the role of interpretation and setting out of guidelines, when it is carried out, the results are not works of art, they are works of criticism. This is true even where the writer also plays the role of criticism as is the case in the development of *hadithi fupi*.

The conclusion on the writer and the critic of *hadithi fupi* is that the eventual adoption of

the features of the short story English into *hadithi fupi* and the popularization of this form as the most appropriate in modern times (Senkoro, 1979/80; Ohly and Msokile, 1992; Mbatiah, 2000) has led to the neglect of the traditional Swahili *ngano* as a subject of serious study. Even with the efforts of Kiswahili scholars at the University of Dar es Salaam of collecting traditional stories from Tanzania Communities and translating them into Kiswahili (Ohly, 1992), the attention does not equal the need to take traditional folklore seriously. This is a problem born out of elitism in the approach to literature not only in Kenya and Tanzania and not only in the study of literature in Kiswahili but in the study of oral literature in Africa in general.

The nature of the **audience** of *hadithi fupi* has been affected by the foregoing issues. First and foremost, modern *hadithi fupi* is a genre that is available mainly in writing. The BBC attempts at the radio version were thwarted by a number of factors especially the dismissive pronouncements of critics who declared them inappropriate for serious consideration as literature (Senkoro *op cit*). Firstly, the fact that it is a written form locked out a big portion of the would be audience. As Mulokozi (2000) puts it, the culture of reading is not a widespread habit in the parts of the world where *hadithi fupi* has biggest number of its presumable targeted audience. Secondly, being a form meant to be appreciated by those highly, educated, and therefore being turned into a school subject, has locked out a big majority of the audience in Kiswahili speaking areas in East Africa.

Due to *hadithi fupi* turning into a high school and university subject has affected the differentiation of its audience. There is therefore the university audiences; the high school audience studying it for examination purpose especially the case of Kenya where the small audience of the educated reader; then there is the bigger literature audience who has access to newspapers in Kiswahili especially in Tanzania. There is then the

audience that Ohly (1992) would call the *mashambani* audience that knows nothing of *hadithi fupi*. This group has maintained the *ngano* genre with minimal support from the very few and occasional educated researcher from institutions of learning. The final picture is that of a differentiated audience unlike the more united audience of the *ngano* in traditional settings in pre-Roman script and pre-*hadithi fupi* epoch.

The above scenario has resulted in *hadithi fupi* being in its present **elitist** state pointing to the reality advanced in the paper that literature can have foreign sensibilities even when rendered in an African language.

### Conclusion: Which Way, Then for African Literature?

In its guiding principles and criteria (theory), its outer and inner shape (structure) and its publics (writer/critic/audience) the short story in Kiswahili is a twin sister to the western-type short story (for example, in English). The only aspect of its mode of existence (ontological situs) that sets it apart from the English short story is the **language**. However, language *per se* is not sufficient to designate a piece of literature to a position of 'African Literature' as Ngugi's (1972, 1981a, 1983, 1988, 2009) arguments seem to suggest.

The examples offered in this paper suggest a more comprehensive methodology of decolonizing African Literature. On return to the drawing board the theory, structure, writer/critic/audience must be subjected to the test. Issues like orality, the written mode, performance among others must be considered and addressed. The consideration of language *per se* leaves Africa with a literature that has an uneasy linguistically freedom but by all purposes still colonial.

### References

Bertanicini, E. *et al.* (2009). *Outline of Swahili Literature: Prose, Fiction and Drama*. Koninklijke Brill, Leiden, 500.

- Chinweizu, O. J. and Ihechukwu, M. (1983). *Towards the Decolonization of African Literature* Howard University Press, Washington D.C., 177.
- Chiraghdin, S. and Mnyampala, M. (1977). *Historia ya Kiswahili* Oxford University Press. Nairobi, 89.
- Gromov, K. (1996). "Tanzanian Press in the Early 1905" in AAP, 47.
- Jahn, J. (1961). *Muntu: The New African Culture*. Grove Press, New York, 267.
- \_\_\_\_\_ (1968). *Neo – African Literature: A History Black African Writing*. Grove Press, New York, 301.
- Madumulla J. S. (1995). Misingi ya Hadithi Fupi ( Mbunda Msokile). *Kioo cha Lugha: Jarida la Kiswahili la Isimu na Fasihi* 1:70-74.
- Mbatiah, M. (2000). *Mwendawazimu na Hadithi Nyingine*. Jomo Kenyatta Foundation. Nairobi, 108.
- Msokile, M. (1992). *Misingi ya Hadithi Fupi*. Dar-es-salaam University Press, Dar-es-Salaam, 219.
- Ngugi, T. (1972). *Homecoming* Heinemann. London. 155.
- \_\_\_\_\_ (1981a). *Decolonizing the Mind* Heinemann, Nairobi, 114.
- \_\_\_\_\_ (1981b). *Writers in Politics* Heinemann, London Ibadan, Nairobi, 142.
- \_\_\_\_\_ (1993a). *Moving the Centre The Struggle for Cultural Freedoms* James Currey. London, 184.
- \_\_\_\_\_ (1993b). *Secret Lives and Other Stories* East Africa Education Publishers Nairobi, 144.
- \_\_\_\_\_ (2009). *Remembering Africa*. East African Educational Publishers, Nairobi, 128.
- Nyagotti-Chacha, C. (1994). The Social Structure of the Waswahili of East Africa. *Maseno Journal of Education Arts and Science*. 2 (1): 92-102.
- p'Bitek, O. (1966). *Song of Lawino*, East African Educational Publishers, Nairobi, 216.
- Philipson, R. (1988). The Swahili novel as disseminator of bourgeois individualism.

*Kiswahili: Journal of the Institute of Kiswahili Research.* 55(1) and 55(2):20-35.

**Ohly, R.** (1992). Introduction to Msokile's Misingi ya Hadithi Fupi (op cite).

**Senkoro, F. E. M. K.** (1979/1980). Hadithi Fupi za Kiswahili. *Lugha Yetu.* 35 and 36:52-58.

**Welleck, R. and Warren, A.** (1949). *Theory of Literature.* Penguin Books, London, 375.

# **Challenges of Reconciliation and Conflict Resolution for the Christian Churches in Eastern Africa: Roman Catholic Church Perspective**

By

**Ambrose O. Mbuya<sup>1\*</sup> and Sussy Gumo<sup>1</sup>**

*1; Department of Religion, Theology and Philosophy, Maseno University, Private Bag, Maseno, Kenya, East Africa.*

*\*Corresponding author e-mail: [ambroseobongo@yahoo.com](mailto:ambroseobongo@yahoo.com)*

---

## **Abstract**

The framework of reconciliation and conflict resolution constitutes an inclusive paradigm within which issues of justice, peace and integrity of creation need to be situated and addressed by the Christian churches in Africa. To engage in evangelization without addressing reconciliation and conflict resolution, both in theory and practice may well be inconsistent and contradictory. Therefore, as well as the Christian churches in Africa addressing issues such as evangelization, development, justice and peace, there is a vital need to name and emphasize the critical importance of the reconciliation and conflict resolution paradigm. These themes are not only mutually complementary but without their inclusive integration there seems to be a fundamental flaw in the approach and vision of the Christian churches mission in Africa. This paper: explores the different dimensions of conflict within the Eastern African context; underscores the challenges of reconciliation and conflict resolution peculiar to or confronts the Roman Catholic Church within Eastern Africa; establishes the role of the church in social development for social transformation in Eastern Africa, and; examines infrastructures the Roman Catholic Church has for reconciliation and conflict resolution in Eastern Africa.

**Key words:** Conflict resolution, Christian churches, East Africa, Roman Catholic

---

## **Introduction**

Reconciliation, Justice and Peace have been part and parcel of the church's mission right from its beginning. The message of Jesus was that peace will come through the willingness to get reconciled and using just measures in restoring wrongs in the community of believers. The mission of the church in addressing issues related to peace, justice and reconciliation cannot but seek authenticity and power from Jesus Christ and the spirit of the father and the son. The added value that the church brings in addressing issues of reconciliation through

justice and peace is to go beyond earthly standards and bringing humanity to the very source of life and fulfillment.

The catholic church in the Eastern Africa (AMECEA) countries have been actively involved in reconciliation, justice and peace issues through Justice and Peace Commissions and networks, issuing Pastoral Letters, involvement in lobby, advocacy and mediation, civic education and promoting interfaith and ecumenical approaches to peace building and conflict resolution within the region. The role of faith based groups in



reconciliation efforts is of crucial importance within the actual context of the region.

Within the spirit of the just concluded Second Africa Synod of Bishops, with a theme: “The Church in Africa in Service to Reconciliation, Justice and Peace: You are the Salt of the Earth...You are the Light of the World (Mt 5:13-14),” the bishops of Eastern Africa (AMECEA) are committed to play their prophetic role by encouraging the entire Family of God to get more actively involved in promoting Reconciliation through Justice and Peace within the region.

### **Dimensions of Conflict within the Eastern African Context**

In order to understand the current conflicts and situational injustices, it is important to identify various multiple transitions that African countries have been going through. There are various historical and socio-political factors responsible for the categorization below. The different transitions are not limited to specific countries since one country could be experiencing multiple transitions (Opongo, 2009).

**Liberalist-populist governments:** in the post-independence period most African governments enjoyed liberalist and populist governments. The centre of power was mainly vested in the governments. The focus was to increase literacy through formal education, tackle poverty through creation of job opportunities, and reduce the death rates through improved medical services. These objectives still remain a reality far from achieved.

**Liberationists/military-democrat government:** this period has seen some military liberationists individuals formalize their governments through “democratic processes” which are often tailored to favor the liberationist. Several countries have gone through series of military resistance for independence or military coups that later transit into some democratic semblance. Such include Uganda, Burundi, Rwanda, South Africa, Zimbabwe, Nigeria, etc. it is

often difficult for liberationists to cede power given that they still live in the liberationist frenzy and are hardly willing to realize that democracy is about checks and balances on their quality of leadership performance. This is the case in Uganda, Ethiopia, Eritrea and Zimbabwe.

**Stale /stagnant democracies:** most African countries continue to experience stale democracies where there seem not to be development and human progress. In these situations democratic processes are manipulated to favor those in power and maintain the status quo. The countries could be “peaceful” but at the same time experiencing a deep discontent among majority of the population largely due to historical injustices, corrupt practices of government officials, poor infrastructure, and partisan institutions of governance, lack of employment opportunities and unfair distribution of resources. Such is the case in Zambia, Eritrea, Ethiopia, Kenya, Malawi, and Tanzania.

**Evangelization-neo-evangelization:** from the spiritual perspective we note that Africa is a continent in spiritual thirst. Many are in search for a deeper expression of their faith. Consequently, there has been a rapid increase in the number of Christians but at the same time an augmented number of churches. Many Catholics have joined the Pentecostal churches because perhaps these churches address a fulfilling need that they do not find in the Catholic Church. Politicians have taken advantage of multiplicities of religious faiths and have co-opted the latter into partisan politics. The confessions by several churches in Kenya of their compromised partisan political participation in the last general elections stand out as a concrete example.

### **Challenges of reconciliation and conflict resolution within Eastern Africa**

There has been a remarkable political and economical progress registered by the Eastern African countries. It is evident that people’s livelihoods have improved and a

new wave of hope created. However, these countries are yet to experience democratic and economic stability that can bring full human development and integrated peace. There is an enormous marginalization of the larger part of the population despite the gains made.

### **Statement of AMECEA Bishop Delegates to the Second Africa Synod of Bishops**

In their presentation during the second African synod the catholic bishops identified the following elements as the serious concerns and challenges for the church in this region. The first concern and challenge was deeper evangelization in Africa. They emphasized that the Church in Africa faces the call to move to a more mature catechesis promoting a true Christian identity and a profound conversion of hearts. The fact that the Catholics could participate in political and ethnic clashes and be involved in serious corruption of public resources show that the church still has a long way to go to promote a faith that does justice. There is need at every level for more serious formation in the Church Social Teaching (CST) and deeper implementation of an inculturation in the theology and not only in our ritual.

The bishops recognized that there is a need for spirituality of reconciliation to strengthen the church through efforts to advance a prayer life and a celebration of the Eucharist that puts reconciliation at the centre. This must include reconciliation with self, with neighbor, with our ancestors, with the earth and with God in whom we move, live and have our being. A renewed celebration of the Sacrament of Reconciliation, often in the context of a communal penitential service, will greatly advance personal and social reconciliation. The bishops stressed on ecumenical and interfaith dialogue in order to promote lasting reconciliation. Hence the church must be more effective in engaging other Christian churches in ecumenical exchanges at all levels. In addition, cooperation must also be sought with Muslim persons and institutions as well as persons and institutions of other faiths in

Africa. Since the family is a central focus for the formation of conscience and the maturing of moral judgments about the good and the right, so essential for the promotion of reconciliation. The African bishops called for more urgency to devise better pastoral responses to meet crises in family life such as HIV and AIDS, orphans, poverty and situations of refugees and displacement.

Concerning the role of women, they decried the fact that in African society, women are frequently not treated as equal to men, are left out of decision-making processes, are excluded from full educational opportunities and fair employment conditions, and are victims of shameful abuse, especially in the military conflicts in the Eastern Africa. Women have the prime responsibility of caring for those that are taken ill with HIV and AIDS and of orphans, while they themselves have the highest rates of infection from the pandemic. They lamented that within the Church in Africa we do not take advantage of God's gifts in the talented and sensitive women in our midst. Yet it is very clear that neither our society nor our Church will do well unless we attitudinally and structurally recognize the role of women and reconcile with the unjust situations in which they are placed. They recognized and were mindful that more than 50% of the members of the church are women and that between 70% to 80% of the active Church collaborations are women.

The bishops stressed their concerns for the youth since "they are the future of the Church." and at the same time "they are the wealth of the present day." As such they must be more effectively incorporated into the life of the Church, the SCCs and other organizations. Given responsibilities and formation, young women and men can and do play an important role in evangelization and in spiritual and social movements and are key actors in reconciliation efforts. They called for a holistic approach in dealing with the HIV/AIDS pandemic, seeing it neither as primarily a medical-pharmaceutical problem nor a matter solely of behavioral change. For

them HIV/AIDS is profoundly a development and justice issue. At a time when some official concerns to the pandemic are receding, the African bishops acknowledged that the Body of Christ has AIDS, and provide a priority response fitting to the Family of God.

They recognize that too many of the youth in the Eastern Africa (AMECEA) countries are out of school. The bishops stressed that ways must be found to strengthen the ministry of education that in earlier years so distinctively marked the Church's apostolic endeavors, so that Catholic Schools at every level are promoted. They said that the Catholic schools must not be seen as "exclusive" or commercial entities. On sustainability and accountability in the church, the bishops lamented the fact that strong desire expressed for more self-sufficient African Church has been frustrated, in many instances, by severe poverty situations in the dioceses and parishes. But it also has not been realized because the church leaders have failed to communicate to the people their responsibility to be generously supportive of the Church's pastoral presence and activities.

The practice of "tithing," for instance, should be encouraged in variously appropriate forms. But central to sustainability must be greater accountability and openness in the reporting on Church finances and always a severely honest handling of all funds. They recalled that in the first African synod there was a stress for a Church that relates closely to the people's real needs and demonstrates an unquestionable integrity of lifestyle among all the Church ministers. There should be some form of "monitoring and evaluation" (M&E) that checks the relevance and credibility in ways that strengthens an effective pastoral approach. A Church that desires to be in service to reconciliation, justice and peace must be both sensitive and credible.

The African bishops emphasized the need for both attitudinal change and structural tools to more effectively promote the reconciliation in this region. For these bishops, this is reconciliation not only in violent conflict situations but also in circumstances of political economic, social and cultural differences. In too many instances the Church is ridiculed or ignored when it speaks out on issues of social justice. They also recognized that the church has often failed to take advantage of opportunities to contribute to public discourse about priorities and policies. They proposed that programmes such as parliamentary liaison offices and representation at regional bodies (e.g. AU) should be instituted and National and regional Justice and Peace Commissions be strengthened. On peace and security, the bishops appreciated that a more accurate historical understanding of how conflict situations have arisen in the region is necessary since the present can only be respond to if the past is known. Moreover, the church should see to the establishment of some permanent structures to respond to conflict crises so that there is not such a time-lag in reacting to something like electoral fraud.

On political governance, the bishops said that some improvement has been experienced in democratic process in some Eastern African countries in terms of introduction of multi-partyism, constitutional reforms, human rights protection even though this has not been universal and sustained. Guided by the Catholic Social Teaching, the Church should be more active in advocacy efforts to improve governmental services, curb corruption, train politicians and public servants, form good citizenship, and encourage responsible voting. The bishops lamented the impoverishment of the majority of the people in eastern African countries. There is great suffering and marginalization of the people in the region. They stressed that advocacy efforts for better government policies and promotion of

improved church social services must be a priority of pastoral response. The “preferential option for the poor” should provide a fundamental question to evaluate government, business, church and personal choices.

Environmental issues in Africa were given prominence in the African synod. The bishops recognized the fact that challenges of climate change and global warming, particularly, affect the local people. Serious draughts are causing food security problems and promoting human migrations that are not always peaceful. In several of these countries, extractive industries are creating pollution troubles that foreign investors are not always responsive to. Forests are cut, but new trees are not planted. They observed that ecological reconciliation is very important for social reconciliation.

### **Situational Analysis of Issues of Justice and Peace in Eastern Africa (AMECEA) Countries**

Kenya witnessed brutal murders, rape, child abuse, assault and general insecurity in 2001. After the December 27, 2007 General Election and the Post-election violence that followed it in January and February 2008, Kenya again witnessed the worst destruction of property and human life since independence. This was as a result of the neglect and failure to face and settle past similar sporadic tribal clashes. Kenyans swept under the carpet all the reports that pointed at perpetrators of the notable cases of violence in 1992, 1997 and 2002 that killed, maimed and displaced hundreds of thousands, which have never been addressed. The violence experienced affected everybody, crippled the economy and created long-term enemies.

Many Kenyans are humiliated because they cannot attain the basic necessities of life. There is corruption, dictatorship, land-grabbing, and lies that make the majority of Kenyans especially the poor, the voiceless, and the youth, feel out of place. There is the state of homelessness for the slum dwellers,

evicted people, squatters, clash victims, refugees, and street children. Insecurity, caused by the greed of individuals or groups which organize violent activities in their desire to hold onto their positions of power, whatever the cost, is evident. The political parties are tribal enclaves, leading to the exclusion of some communities from basic development. Many a time, political and opinion leaders have been observed and accused of disapproving other tribes and inciting their own to violence against other communities, especially during campaigns and elections. Insecurity affects economic growth and interferes with activities of people’s daily lives. It continues to be a big hindrance to the promotion of human dignity and integrity. Poor leadership leads to disunity in an area and, subsequently, lack of development.

Land rights affect people directly and indirectly. Tribalism results in much violence, discrimination and greed for power and wealth. Lack of accountability has left many impoverished and disenfranchised. Leadership and youth development need to be mapped in a realistic way. There is a need for good leaders and at the same time a need to empower the youth so that they can take leadership seriously. Problems of the youth need to be addressed or they will be lost to violent-gangs-for hire and drug peddling.

The Aids pandemic has affected all in Kenya and its impact is felt by all. The scourge is taking a big toll on the country’s social and economic sectors. Children suffer most by being infected and being orphaned. In Kenya today, many people are dying of Aids related diseases, children getting infected and orphaned and many more people are rendered dependants.

Kenya is experiencing an environmental crisis. Some Kenyans have been negatively changing the face of Kenya. There is unregulated and unauthorized encroachment on water catchment areas like the Mau, Mt Kenya, Mt Elgon and the Aberdare forest. The forests have been destroyed, causing

immense havoc and climate change. Rivers, lakes, dams and other water sources are running dry and the rains are erratic and inadequate, food is scarce and thousands of livestock are dying. Over 10 million Kenyans are facing starvation. Lack of affordable food continues to plague the country because rains have become irregular. This has seen prices of essential commodities escalate to unaffordable levels for many. Different species of animals are endangered and there are increased cases of wild animals invading people's homesteads. Diseases, which were once treated through herbal remedies, are now costly to manage because trees and shrubs with medicinal values are scarcer. With deforestation, there is an imbalance in the ecosystem. The sacred values that connected people with nature continue to die. There is frequent power rationing while desertification is on the rise and irrigation schemes are threatened. The planting seasons can no longer be told, making many people lose valuable time and money. In 2006 drought caused death of people and animals, and the floods caused loss of life. Degradation of the environment now requires urgent attention. The principle of stewardship challenges Kenya to use their resources for themselves and for future generations. Kenyans must think of positive things to be done in order to reverse the climate change.

Besides poverty and unemployment in towns and city slums, land and tribal clashes, small acreage per family that cannot support many families, large scale malnutrition have aggravated hunger in Kenya. The lack of food is also attributed to poor farming methods, lack of proper planning, violence and displacement. As Christians, we are called upon to seriously address our habitat, the environment, food security and affordability.

The problems Kenya is facing emanate from lack of constitutionalism. Many of Kenyan institutions are run without proper rules and procedures. A Constitution, that does not clearly state how resources should be shared,

is partly to blame for the violence. More often than not, community conflicts are over resources. The Constitution that Kenyans are looking for must cater for all their needs; a constitution that brings healing and reconciliation by treating all people equally, one that distributes the country's wealth equitably and eliminates the culture of impunity. The people who have been victims of violence need to be healed.

Ethiopia and Eritrea have rich cultural heritage and deeply religious in their identity, but the boarder tensions that have led to inter-state wars remain a big challenge of peaceful co-existence. The two countries have perennial droughts and food shortages, and have failed to institutionalize accountable leadership. Ethnic discrimination and religious tensions have weakened the little democratic progress that has been made.

Sudan, Tanzania and Zambia experience the challenge of poor use and distribution of national and natural resources, particularly given the large amounts of mineral resources. The governments of these countries have signed mining contracts with multinational companies that reap the respective countries of the maximum profits while at the same time having a serious impact on the environment. Conflict and insecurity have hampered social integration and fair economic distribution in Uganda and Sudan. The northern Uganda conflict between the Lord's Resistance Army (LRA) and Uganda government has impoverished the North and retarded the country's full economic development.

Economic disparities evidenced by inequality of household incomes, ownership of lands as well as poor economic performance of a country, can also lead to conflict. These conditions breed general discontent against government, leading to civil strife and protests, formation of armed guerilla groups which lure the unemployed youth, to the power of the gun, hence creating an alternative source of income through

extortions and criminal activities. In Kenya this has been noted by the growth of militia groups during election periods and their subsequent mutation into extortion rackets and criminal menace.

Sudan equally faces the problem of equitable distribution of resources and integral development. The country is notably the biggest country in Africa and has endured the longest and bloodiest fratricidal conflict in the continent, lasting more than 40 years. The country is endowed with enormous wealth.

Contrary to the globalization promises of poverty reduction and development “the actual number of people living in poverty has actually increased by about 100 million. This occurred at the same time that the total world income increased by average of 2.5% annually.” Worst still little or no structures have been established to address the growing problem of the increasing number of marginalized among the marginalized. Secondary marginalization has grown rapidly in poor countries. Among the population in the secondary marginalization are the HIV/AIDS Victims, orphans, street children, disabled or handicapped, victims of civil wars and genocide, child soldiers, bonded laborers, drug addicts and ex-convicts. These have been regarded as non-players.

The church has to be vigilant in identifying economic policies that give false economic growth that is not reflected on the lives of the people. As such it has to provide alternative mechanism to measuring economic, social, and political wellbeing of the human person. Pope John Paul II (1988) asserts:

Moreover, one must denounce the existence of economic, financial and social mechanisms which, although they are manipulated by people, often function almost automatically, thus accentuating the situation of wealth for some and poverty for the rest. These mechanisms, which are maneuvered directly or indirectly by

the more developed countries, by their very functioning favor the interests of the people manipulating them and at the end they suffocate or condition the economies of the less developed countries.

It is important for the church to be familiar with the subtle economic policies that often tie African governments to contracts that make them poorer.

Hence, we note that in order to address the various levels of conflicts and achieve full economic and democratic integration centered on the human dignity, the Eastern African countries need to address the following:

- Poor distribution of national resources.
- Lack of democratic structures.
- Authoritarian regimes that marginalizes specific groups of people.
- State failure to guarantee the security of the population, especially of the marginalized communities.
- Border dispute between states especially when there is natural wealth at stake.

The envisioned social change for the Eastern African countries will have to focus on the common good of the society. The church (*Gaudem et Spes*: 1965: No. 30) reiterates that, The best way to fulfill one’s obligations of justice and love is to contribute to the common good according to one’s means and the needs of others, and also to promote and help public and private organizations devoted to bettering the conditions of life.

Democratic reforms, particularly in the developing countries, ought to be geared towards fostering accountability, transparency, efficiency, freedom from corruption and security of persons and property. Increase in democracy creates opportunity for creativity for new ideas and a favorable climate for economic development. Such an environment facilitates trade and

benefits of globalization most effectively by expanding participation in political, economic and social systems.

The disillusionment on what democracy can offer has created a new crisis in Africa leading to conflicts and protests for change. In the Eastern African (AMECEA) region today, and in many African countries, the hitherto stable countries are facing the impatience of their people who can no longer bear the rise of the cost of living. The Basic Needs Survey carried in Kenya, Zambia, and Uganda has all shown that the cost of living has been going up between 10-22%. Most people can no longer bear the costs. This means that the biggest challenge for most African countries today is sustainable livelihoods. If democracy is to gain any relevance it has to address the question of unequal distribution of resources, lack of participation in the organization of the society and accountability.

The sustainable livelihood crisis has been witnessed in several countries of Africa. Increasing food prices have emerged as a major indicator that most African economies are unsustainable, and that the rising oil prices will destabilize democratic and economic gains further. The hard economic times have been marked by the food riots in Cameroon, Senegal, Burkina Faso, Kenya, etc.; violence against immigrants in south africa has confirmed the xenophobic attitudes provoked by lack of employment for many south African youth; and lastly Kenya has equally witnessed post-election violence which to a great extent touches on issues of poor distribution of resources and the need for political and economic reforms. Unless these issues are addressed African countries will be faced, in the next two decades, with a major crisis that could spiral into a "people's revolution" consequently unseating the wealthy from their comforts. In other words, we need a new philosophy of development.

### **The role of the church in social development for social transformation**

The church has indeed a vigilant role to play in social transformation: working against social injustices and instituting just structures within the society. The church has been at the forefront in the provisions of social services in Africa which have consequently been key to development. The concept of development has constantly been used to refer to the material consumption and progression in a society. Thus, material consumption and Gross Domestic Product (GDP) become the index of progress. But the debate has recently shifted to focus on social development. The Catholic Bishops of Kenya (1982) stated that:

Justice demands that all citizens have a right to share in the wealth of our country...It follows that all should have some share in land ownership, in available material resources, in politics aspirations, in education, in government services, etc. the use of unjust means of any form, by anyone, is against justice.

The church has the role of bringing the voice of conscience to the process of development. Subsequently, development without a human face is development founded on a false premise of self-enrichment and promotion of statistical development, and not human development. The church has to be intrusive in promoting faith grounded on responsible citizenship which holds leadership accountable to the common good. In other words, we need an alternative discourse that can promote sustainable livelihood while at the same time increase popular participation in structures of governance.

The Episcopal Conference of Uganda reminds us that "Citizens ... must aid in keeping the country at peace, in finding better means of production, better ways of living, in enforcing respect for the laws of God, in influencing public opinion, in raising the level of public morality and in securing social justice." In order to increase the citizen participation, it would be important to reconcile divided communities. Hence,

the mission of reconciliation is a central pastoral commitment.

In the midst of violent contexts in the Eastern African region, the church has become more overt in working against factors that ignite, exacerbate or increase conflicts. This is evident through the church's schools and colleges, hospitals, formation and trainings in leadership and human development as well as statements against social injustices. However, new trends of conflict have challenged the church to play an active role in mediating various levels of conflict. Currently, within the Eastern African region, there are social, economic and political conflicts that could degenerate into political-economic crisis in Malawi, Zambia, Eritrea, Sudan, Uganda and Kenya.

Working for peace and justice is indeed a deliberate commitment by the church to build kingdom of God on earth. It is a kingdom built on gospel values of love, forgiveness, tolerance, mercy, and generosity. This process includes diverse and focused activities, immediate and short term, that promotes peace and curb violence in conflict settings, on both the micro and macro levels of the society. The participation of the church in peace-building and conflict resolution is thus a foresight that not only contributes to eventual ending of particular conflicts but also conservation of limited resources and preservation of human life.

However, besides intervening in conflict and reconciling divided societies, the church has today an important task of proposing alternative mechanisms for change that address full human development. There is a need for a new discourse against economic and political liberalism. Hence, the church has to speak out for the poor by promoting social development as an alternative approach to integral development that responds to needs of the entire person. As Pope John Paul II (*op.cit*: no. 10) asserts:

To ignore this demand could encourage the temptation among the

victims of injustice to respond with violence, as happens at the origin of many wars. Peoples excluded from the fair distribution of the goods originally destined for all could ask themselves: why not respond with violence to those who first treat us with violence?

The discussion above shows that the church is an important agent of change, particularly in transforming conflicts in Africa. Thus, the primary focus of the work for reconciliation is social justice which entails establishment of a harmonious coexistence between individuals, and assurance that every human person has a role to play in the society, and that the society has the responsibility of providing the necessary provisions for a decent life.

The church has four main crucial roles to play in transforming conflicts in Eastern Africa. The first is that the church should never lose its prophetic voice. It has to be the "salt of the earth...the light of the world" with the conviction that we all have an obligation to transform the situations of injustice in our midst. Secondly, the church has to be vigilant, always committed to make "visible the real presence of God's saving action in time and space." Vigilance calls for a foresight in anticipating the impact of political, economic and religious policies on the population. The church has to include catholic professionals in the analysis of social contexts in order to give informed challenge and advice to the government. Thirdly, the church has to be intrusive as an agent of social change. The church has the liberty to intervene against societal and government practices that violate human dignity. The fourth is that the church has to live in solidarity with its people as an agent of forgiveness and reconciliation. The vital interventions for change in conflict and post-conflict periods are mediations through dialogue and conflict intervention, and an integral process of forgiveness and reconciliation that seeks to heal the wounds of conflict, respectively.



## **Roman Catholic Church's infrastructures for reconciliation and conflict resolution in Eastern Africa/AMECEA region**

### **AMECEA Justice and Peace Desk**

AMECEA is an acronym for "Association of Member Episcopal Conferences in Eastern Africa" It is a Catholic service organization for the National Episcopal Conferences of the eight countries of Eastern Africa, namely Eritrea, Ethiopia, Kenya, Malawi, Sudan, Tanzania, Uganda and Zambia. Djibouti and Somalia are affiliate members. The AMECEA Justice and Peace Desk is mandated to promote justice and peace in society and in the Church and works towards a change of unjust structures as part of the evangelizing mission of the Church. Established in 2002, the Justice and Peace Desk works towards: the establishment of a network of the Justice and Peace Commissions in the AMECEA region and the formation of a Global African Justice and Peace network; capacity building and supporting the formation of new Justice and Peace Commissions where they do not exist yet; formation programs on Justice and Peace and Social Teaching on the Church, in order to create awareness on these issues and foster a commitment; building a culture of peace and working towards the resolution of conflicts in the region; developing and fostering a spirituality of justice and peace; fostering the commitment of the Church and Christians to live the preferential option for the poor; lobbying regional and international organizations, to make the voice of the Church heard on issues influencing the life of the people in the AMECEA region; networking and supporting the Justice and Peace Commissions and dioceses working with refugees; formation of pastoral agents working with refugees, and; giving information on and analyzing issues related to justice and peace affecting the region.

### **Kenya**

The National Justice and Peace was established on the mandate of the Kenya Episcopal Conference on 1st January 1988. The Justice and Peace Commission is the

executive organ of the Kenya Episcopal Conference for Justice and Peace issues. The objectives of the Justice and Peace Commission are set out as: to approve the contents of formation programmes and Lenten campaign; to discuss and make decisions on publications of the social teachings of the Church in order to make them available in simple format and language; to work for the eradication of injustice wherever it is seen to exist by analyzing the situation in the light of the Gospel, planning relevant steps and action in order to contribute to their solutions, and issue official communiqués as to the stand of the Catholic Church in Kenya; to advice, encourage and support the diocesan CJPC and other groups involved in justice and peace issues, and; to cooperate with other institutions, churches and peoples in the spirit of Christian Unity. There are many and varied justice and peace issues that has been addressed by the bishops of Kenya in their annual Lenten campaigns. The catholic bishops have consistently condemned violence meted out on the poor, voiceless and the marginalized. They also condemned the impunity manifested by politicians. The church believes that human dignity must be protected and respected at all times.

### **Ethiopia**

The Ethiopian Catholic Secretariat (ECS) Justice and Peace Desk activities revolve around three main programmes, which are complementary to each other: promotion of justice and peace; promotion of human rights programme at the grassroots level, and; capacity support for peace building. The Ethiopian Catholic Church undertakes the justice and peace initiative throughout the country by its various diocesan offices. Out of the 10 dioceses, 9 of them have justice and peace. The establishment of the justice and peace offices at the diocesan level is fully supported by the bishops' conference and individual bishops. This shows the commitment of the church to stand for the poor and the marginalized members of society where there is injustice,

discrimination and marginalization of the people.

The promotion of the justice, peace and human rights initiative is taking root in different dioceses with the involvement of communities and religious leaders. In some dioceses the initiative has gone so far that there is a participation of local government officials in different workshops organized for the community. This is witnessed in such a way that all the program activities of the justice and peace desk are executed effectively by the strong desire shown by the diocesan offices to undertake the initiative very willingly.

Capacity support activities in those dioceses that just established and those that are already functional is underway as part of the Ethiopian catholic secretariat's strategic plan to strengthen Diocesan Catholic secretariat. In this regard the ECS Justice and Peace Desk has undertaken a number of awareness raising activities at national and diocesan levels to inject the concept of justice and peace; social teaching of the church and basic human rights at the grassroots level. There is enormous participation in peace and relationship building workshops from different religious leaders, government officials, the youth and women, and the communities. The Justice and Peace Desk at the national level has developed a five year strategic plan in order to capacitate diocesan Justice and Peace initiatives.

### **Achievements**

Under all the programmes, remarkable achievements are registered both at the national and diocesan levels especially in the areas of awareness raising and trainings and workshops.

### **Sudan**

Sudan is a troubled land in which the north and south fought two bitter wars that have produced crippled economic problems for the country. Since the declaration of independence in 1965, violence, not peace, has been the country's norm. The Sudanese

have witnessed transitions including three parliamentary democracy and three periods of military rule. Two million people have died during the last civil war (1983-2005). More than 4 million displaced. Sudan holds the record of displacement in the world.

Sudan's basic problem is a centralized government dominated by a small ethnic group made up of mainly Arab tribes who reside along the Nile in northern Sudan. After taking over the mantle of power from colonialists in 1857, they marginalized the rest of the Sudanese and made several attempts to impose its Arab and Islamic identity, and culture on a multi-ethnic, cultural, religious and racial society of Sudan.

Islamic religion has been significant in defining identity in Sudan. Issues such as racial discrimination and disparity in wealth and power between the north and south are part of the conflict. The policy of religion within conflict in Sudan is derived from both its influence on ethnic identity and close links between nationalism and religious beliefs, Islamic renaissance and the implementation of the Islamic Sharia in the country.

From 1957 to 1958, two constitutional draft committees composed largely of Islamic based parties in the north decided for promulgation of an Islamic constitution for an Islamic Sudanese state. Similarly, all the military led regimes that took over power from elected governments, inherited the same policies from their predecessors. A discriminatory policy of licensing for the Christian churches was introduced in 1962; finally in 1964 all foreign missionaries were expelled from the south. Islamic penal laws were introduced, applicable to both Muslims and Christians. The state openly began to use political power, security organs and government ministries to promote Islamic laws. The request for licensing of churches was for the control of the spread of Christianity in southern Sudan.

From 1989 the nature of the Sudanese state changed completely; religious fanatics and zealots propelled to positions of power in the state. Once again, islamization of the whole country took place with full weight of the laws. The participation of non-Muslims in government institutions, offices, colleges and civic bodies became more difficult. Religion was the key to access to different executive positions in the government and social benefits. Muslims who show fanaticism enjoyed favor with the state.

Southern Sudan has been greatly oppressed, disenfranchised, displaced and devastated for now fifty years since Sudan achieved its independence. Injustice, religious discrimination and marginalization are the direct reasons of the conflict. More than 2.8 million southern Sudanese and other marginalized people have been killed, maimed, and many millions were driven away from their homes, displaced politically, socially, economically and culturally. Many of their traditional social family and values systems have been destroyed and eroded by direct and indirect policies of Sudanese government dominated by Arab ethnic group; who believe that Islam and its associated Arab culture are essential elements of Sudanese identity. The positions of north on Islam and that of the south on self-determination, secularism and democracy seem irreconcilable.

### **Interventions**

Many mediators have worked tirelessly over the years to bring peace to Sudan, namely; Nigeria, IGAD peace, South Africa, and OAU (AU). The Catholic Church has always spoken against the war and advocated for peaceful settlement of the conflict by taking the following steps: in October 1983, the bishops made an appeal to Christian faithful and all peace loving Sudanese of goodwill during the inauguration of the jubilee Year of Redemption, in January 1993, the bishops, recalling the appeal made in October 1983 reminded the Sudanese in these words:

We the catholic bishops of Sudan asked all Sudanese of goodwill in October 1983, since then, we have continued individually and jointly to issue statements and appeals for peace; to contact the government, and in 1986 even the SPLA. We urged our Christians communities to keep on praying for peace and justice in our country and practicing what they prayed for (Sudan Bishops pastoral letter: 1993).

The bishops have since issued a number of pastoral letters and appeals for peace in Sudan. Their last appeal was on august 2003.

### **Ecumenical action**

The churches in Sudan and their partners contributed for peace through workshops, conferences, meetings, and commissioned policy papers which were transmitted to the parties in conflict, IGAD Secretariat and international community. The churches under the umbrella of Sudan Council of Churches (SCC) produced a document which formed the basis for formation of Sudan Ecumenical Forum (SEF). SEF brings together the Sudanese church with its international partners to work jointly for peace in Sudan through advocacy at international levels/forums. The Sudanese and international partners noted that support given to the local churches and church's councils and conferences within Sudan by World Council of Churches (WCC), All African Conference of Churches (AACC), Caritas Network and Catholic organizations were most effective. From 2002, the Sudanese church and Uganda's joint Christian council organized a number of peace related meetings culminating to the Entebbe III meeting in December 2003; where representatives of the armed groups (militias groups) affiliated to Islamic government in Khartoum were present. The meeting was a civil society forum, its aim was:

- To seek and understand the nature, importance and realization of the

reconciliation among the fragmented Sudanese society; good governance during interim period as stated in the comprehensive peace agreement.

- To begin the process of dialogue and reconciliation between different parties, groups and people of the south Sudan and marginalized area.

### **Reconciliation process**

- On may 2, 1993, the bishops of the catholic church issued a pastoral letter on dialogue.
- In April 1993 Peace and Development Foundation, a government ministry convened the conference on religions in the Sudan.
- Government of the Sudan on October 5, 1994 organized interreligious dialogue. Catholic Church presented a paper under the title “Can We Sustain Dialogue?”
- The Khartoum Forum for Interreligious cooperation and Peace was organized by Council for the International Peoples’ Friendship in collaboration with Sudan christian churches (SCC) and the international center for religion and diplomacy, in 2002.
- The catholic church became one of the three actors as mandated by Entebbe meeting to follow up the reconciliation process that took steps for contacting the SPLM/A, in may 2004.

### **Uganda**

Democratic Republic of Congo and Sudan have similarly been gravely affected by conflict which sent their nationals fleeing to Uganda in their tens of thousands as refugees. Northern Uganda and particularly Acholi Sub-region which also forms Gulu Archdiocese has been hardest hit by a vicious internal armed conflict since 1986. Gross human rights violations ranging from killings, rape, torture and abduction have been simultaneously meted out on this

population by the warring parties, the government forces and the various rebels. Northern Uganda has been embroiled in a devastating armed conflict for over 22 years. It has been a conflict that has been embroiled in a devastating armed conflict for one Joseph Kony on the one hand and the Government of Uganda on the other.

The first ten years of this active conflict was characterized by killing, mayhem and abduction of history. These highly institutionalized and orchestrated heinous acts were meted out on the children of God in northern Uganda by the belligerents. The abduction of children increased their vulnerability and indeed heightened fear; privation and dependence in the community such that there was apathy. The government who should have provided protections to its citizen was very much inadequate.

### **Interventions**

The religious groups in Acholi sub-region came together and formed Acholi Religious Leaders Peace Initiative (ARLPI), which is the unity of different faiths for a common cause of peace as well as other issues meant for the good of the people. The religious in northern Uganda have for years voiced out the concern of the voiceless and suffering people for peace, and maintained the position for a peaceful resolve to the armed conflict.

The formation of ARLPI was aimed at having a concerted effort for peace, human dignity through disbandment of IDP camps and an amnesty for ex-rebels among other things. ARLPI has focused on playing a semi-mediation role between the government and the rebels, by building trust between the two warring parties as well as trust from the parties towards civil society in the region as a whole. Religious leaders have met with LRA rebels in their hideouts and discussed the amnesty offer from the government among other things.

The Amnesty Act originated from the cry of the citizens of Uganda, that in order to end

conflicts in Uganda, there was need to have amnesty. Amnesty has been based on culture and traditions of the people in a sense that amnesty enables two conflicting parties to come together to resolve their differences rather than fight.

Premised on the theme of “Reconciliation through Justice and Peace” quite a number of interventions were made. Top on the long list of interventions was the position taken by the civil society in northern Uganda- that the most appropriate approach to resolving the northern Uganda armed conflict was through dialogue.

Another area of intervention that made a significant contribution in giving visibility to the 22 year old conflict was advocacy. The sustained advocacy which emphasized among others; forgiveness, truth telling, reconciliation, justice and peace was adequately done at the community level. It is for this reason that the amnesty law was put in place to receive those former LRA combatants would renounce rebellion. The community advocacy campaign had prepared the soft ground on which the former combatants would land through re-integration into the very community brutalized by the activities of the Lord’s Resistance Army of which the returnee were integral part.

Another area of intervention by ARLPI created a bridge between the LRA fighters and Uganda government. It took life threatening encounters for the leaders to gain access to the LRA senior commanders. This access, contacts- which later became known as a bridge was laid open between the belligerents. ARLPI also accommodated certain aspect of traditional justice system which promotes reconciliation in its programme.

ARLPI was also involved in research work on the IDP camps and released a report. The advocacy following this research was to let the world know of the fatality of the camp

and God’s flock need to be freed from these camps.

Following the post –election crisis in Kenya, the church undertook the pastoral task of healing the wounds of division, especially by Jesuit Hakimani Centre. Similar initiatives for peace and reconciliation mushroomed into multiple activities for peace and reconciliation throughout the country, and developed into what we now call in Kenya, *Channels for Peace* under the auspices of the Kenya Episcopal Conference.

### **Summary of Roman Catholic Church’s response to challenges of reconciliation and conflict resolution in Eastern Africa**

A number of initiatives by church are aimed at forming people to deal more creatively with social and political tension at both local and national level. In the work of formation and in the activities that flow from it, churches in some areas have come together to pool material and spiritual resources, and form an ecumenical bond. Networks of ecumenical and civil society groups have also provided a creative response.

#### **Education/Formation:**

- Developing skills in conflict management
- Empowerment of women
- Empowerment of youth through awareness/ skills training program
- Civic education
- Education in human rights
- Education in advocacy and lobbying
- Promoting programmes related to the healing of memories
- Promoting the social teaching of the church
- Formation in the gospel values and principles

#### **Activities:**

- Monitoring situations of injustices
- Providing support for victims of injustice

- Developing contacts with traditional leaders who have significant authority in rural areas
- Developing contacts with urban and rural councils in view of promoting christian values and principles
- Developing contacts with leaders of the security services in order to diffuse tension and promote impartiality
- Developing contacts with local and national political leadership, insisting that leaders are servants of the electorate
- Writing and disseminating pastoral letters and statements
- Promoting intercessory group prayer for peace based on justice
- Non-violent protest
- Advocacy for and with the poor
- Lobbying on special issues
- Facilitating dialogue and negotiation between groups in conflict

### Conclusion and Recommendations

From the above discussions it can be observed that among the conditions that block reconciliation are wars, lack of mutual basic needs, hunger and disease, especially the crushing weight of debt, HIV/AIDS, corruption, unjust trade practices and environmental degradation. The church has to live in solidarity with its people as an agent of forgiveness and reconciliation. The vital interventions for change in conflict and post-conflict periods are mediations through dialogue and conflict intervention, and an integral process of forgiveness and reconciliation that seeks to heal the wounds of conflict, respectively. Since peace remains precarious within the Eastern African region, mediating conflicts and reconciling people need concerted efforts by all key players. There is need for involving all key players through lobbying and advocacy. It is through greater community participation in addressing peace and justice that long lasting solutions on reconciliation can be achieved. The region needs efficacy and competent

brokers in peace and reconciliation fields. Persistence social tensions in the region impede progress and breed political disturbances, armed conflicts and tensions. Peace cannot be adequately addressed in terms of unanimity or tranquility imposed by force or keeping power in hands of the powerful. Peace demands working for establishing justice and fair ways of treating and living with each other, establishing just structures, respecting, protecting and promoting rights and duties of citizens.

### References

- African Ecclesial Review.** (2002). *United With Sudan: A Suffering Church*. July-August 2002. Vol. 44. Nos. 3 and 4: Eldoret: AMECEA Gaba publications.
- African Ecclesial Review.** (2008). *Reconciliation through Justice and Peace- 1*. Vol. 50. Nos. 3 and 4. September-December 2008. Eldoret: AMECEA Gaba publications.
- African Ecclesial Review.** (2008). *Specific challenges to evangelization in africa-5*. Vol. 50. Nos. 1 and 2: March-June 2008. Eldoret: AMECEA Gaba publications.
- African Ecclesial Review.** (2009). *AMECEA 16<sup>th</sup> Plenary: Reconciliation through Justice and Peace in the AMECEA Region*. Vol. 51. No. 3. September 2009. Eldoret: AMECEA Gaba Publications.
- African Ecclesial Review.** (2009). *Reconciliation through Justice and Peace- 2*. Vol. 51. Nos. 1 and 2. March- June 2009. Eldoret: AMECEA Gaba publications.
- Bennet, M.** (2006). *Faith and Social Justice*. Nairobi: Paulines Publication Africa.
- Hearne, B. *Struggling For a New World*. Eldoret: AMECEA Gaba Publications.
- Henriot, J. P. et al.** (1990). *Catholic Social Teaching: Our Best kept Secret*. Washington D.C: Orbis.
- John Paul II.** (1988). *Sollicitudo Rei Socialis*. Nairobi: Paulines Publications.
- Magesa, L (Ed.).** (1999) *The Prophetic Role of the Church in Tanzania*. Eldoret: AMECEA Gaba Publications.

- McGarry, C et al.** (1992). *A light on our Path: A Pastoral Contribution to the African Synod*. Nairobi: St. Paul Publications-Africa.
- Mejia, R. (Ed.)**. (1995). *The conscience of the society: the social teaching of the catholic bishops of Kenya: 1960-1995*. Nairobi: Paulines Publications.
- Muyebe, S. and Muyebe, A.** (2001). *The African bishops on human rights: Resource Book*. Nairobi: Paulines Publications Africa.
- Ryan, P (Ed.)**. (1999). *The Role of Christians in Politics in Africa Today*. Nairobi: Paulines Publications Africa.
- Synod of Bishops: Second Special assembly.** (2006). *Lineamenta: the Church in the Service to Reconciliation, Justice and Peace*. Nairobi: Paulines Publications Africa.
- The African Synod, A Step Forward. Tangaza Occasional Papers/ No. 2.** (1994). Nairobi: Paulines Publications of Africa.
- Vatican II, Pastoral Constitution on the Church in the Modern World.** (1965): *Gaudem et Spes*, 7 December 1965.

# Linguistic Effects of Globalization: A Case Study of French for Specific Purposes (FSP) in Kenya

By

Mubalama Mulenda<sup>1\*</sup>, Muteba Kazadi<sup>2</sup>, Ndiabou Touré Segá<sup>3</sup>, Clara Bulili<sup>1</sup>

*1; Maseno University, Kenya*

*2; Masinde Muliro University of Science and Technology, Kenya*

*3; University of Cheikh Anta Diop, Senegal*

*\*Corresponding author: [fmul2003@yahoo.com](mailto:fmul2003@yahoo.com)*

---

## Abstract

The study of French for Specific Purposes (FSP) is a topical subject in this era of globalization. Kenya requires people who can communicate in French in the various specialized areas. It has become crucial in Kenya to respond to the French language needs of students learning tourism and hospitality among other domains which have already shown an increasingly important role in the economy of the country. Functional French has become a necessity in this case.

**Key words:** French for Specific Purposes, globalization, language needs analysis, communication situations

---

## Introduction

Professional mobility is currently developing fast. People have increasingly found themselves working among multilingual groups, either in their own country or in foreign countries. Globalization, which opens up the world, has necessitated learning of other languages. It has now become a topical subject.

Finance and international trade presuppose international market and capital movement world wide. This goes beyond national and linguistic frontiers. International relations, which are political, cultural and economic have increased in a particular manner. From regional and national markets, we are now in a global economy. Multinationals have also developed and require skilled personnel from all corners. Finally, the mass

production of consumable goods necessitates a wider market across the world.

Taking into account internationalization of the economy, commerce and culture, languages have become very useful. Knowledge of these languages is part of the required capital first competition. There is therefore an imminent desire to learn these languages on the one hand for professional use and on the other for communication among individuals since language is a system of expression and communication belonging to a social group. It is important to look for a common language, much more practical for communication that can improve relations among the countries. At this stage, we can ask ourselves which French is relevant for Kenya in this era of globalization.



Language has the potential of acting as a key allowing access to a new universe. In a certain way, the frontiers of our universe are linked to those of our linguistic knowledge. One who learns a new language opens himself/herself to a new cultural and linguistic system.

This article is based on a reflection concerning FSP, which is putting it into perspective with the new realities brought about by globalization that has continued to grow. This study concerns first of all, the language needs specifically the language competences required in response to personal and social needs. Secondly, we are interested in finding out how the Kenyan education system has tackled the language needs of students as well as the role the institutions of higher learning should play in this regard.

### **Notion of Globalization**

Globalization is an expansion and harmonization of interdependence links between nations, human activity and political systems at the world level. This phenomenon touches people in all areas and the impact is being felt. It also evokes transfer and international exchange of goods, labour and knowledge.

Learning of FSP is a necessary condition for globalization for developing countries, like Kenya where multilingualism is wide spread. FSP can facilitate expansion and harmonization of human activities internationally through exchange of goods, knowledge, sharing of information, arts e.t.c. At the center of this formidable globalization movement, far-reaching exchanges are put in place. Languages are the essential vector and play a major role.

### **FSP, vector for development**

For about 20 years now, the nature of demands for French has changed. They are now oriented towards more professional French, more work oriented, that is for professional use. In fact, the enterprise is prescribing the linguistic training. This

evolution has provoked an emergence of a need of recognition and validation of the languages acquired in the training. However, the fact is that ignorance of the languages in question is the main obstacle towards communication and in this case, to development. The acquisition of a foreign language gives one access to other ways of looking at the world and consequently, at a better understanding of the 'other'. In the global market which is the world today a 'foreigner' no longer exists. We speak of the 'other'. In fact, learning 'the language of the other' and expressing oneself in it has become a necessity.

Kenyan has real language needs in FSP. When two people begin a dialogue on a topic in a domain that is known to both of them, they will straight a way use terminologies relevant to this domain; they will exchange information or give opinions on issues that will not be understood by those who are less informed on that particular topic (Balmet and De Legge, 1992).

The main objective of linguistic acquisition is the mastery of a language as a 'vector of development'. The French language as an instrument of training centered on the needs of the learners becomes the support language for development (Balmet and De Legge, 1992). In professional life, information should be passed on to those in authority, to colleagues and to clients, or also gather documents, to express oneself during meetings or enhance team work. Furthermore, one spends his/her time receiving information. Finally, it is important to be able to communicate about oneself so as to express ones projects, needs or shortcomings (De Sainte Lorette and Goetz, 2008).

In fact, in depth analysis by sociolinguists on the way language can be linked to society is indispensable when formulating programs on communications. It is obvious that it is evolution, political or technological, which results in effect on linguistic relations

between professionals working together from different linguistic origins; on the intervention of the political sphere in the specific form assured at a given time, the diffusion of a language out of its 'natural' territory (Lehmann, 1993).

The importance of history and of the economy, the 'state of the world' and in particular the nature of relations between developed countries and developing ones, are evident in the expressions of the linguistic exchange. The language creates a sign of solidarity between members of a community. It is also useful as a factor of social integration and cohesion. The language is a sign and instrument of power including power that others have to give you an order, to question you, to furnish you with information, to obtain what you want, to protest or to read news. It can also represent political power as language of administration.

It has become important to talk about the aspirations that have different groups of people related to the knowledge of languages. This socio-cultural phenomenon that is explained by various macro and micro political, technological and tourism related reasons, has been marked feature of industrial societies since the end of the Second World War (Renard, 1976).

Everywhere where the language need is felt, a sort of consensus on the approach of the problem is found: the language is no longer considered as a veneer of intellectuals full of foreign 'letters' but rather as a means of communication with others, a means of understanding of their socio-cultural universe, economy and politics. In as much as it is a communication tool, language is well recognized as a social practice. (Galisson *et al.*, 1980).

Every language is a possession both personal and shared, a representation of the world, a way of looking at the world. Language is no longer used only to transmit information but is also as a way of acting on the world. With

globalization, we are in an era where the economy develops very fast. This implies growing internationalization of exchanges for use and thus the need for oral competence directly useful in interpersonal and commercial exchanges.

The economic world is today conscious of the fact that lack of knowledge of languages can be a handicap to commercial negotiation. In this context, the spread of the French language finds its legitimacy, its equality with other languages, the fight for promotion of a language is today a defense for multilingualism (Cuq, 2003).

Economic and political factors give rise to innovations in teaching of languages (Saux cited by Baylon and Mignot, 2003). Learners are no longer concerned about knowing a language but rather being able to use it for communication purposes: understanding and being understood both orally and in writing. Languages have ceased being academic but are now for social and professional use. Study of the French language in Kenya should no longer be considered as a literary study but rather it should be linked to economic improvement of this country so that it can maintain its place as an international language. Language is viewed by the modern linguist as one of the ways of knowing the world (Cabr , 1998).

The socio-political-economic development of Kenya and its entry in the international market has led to new tendencies of teaching French with a marked difference between general French and French for Specific Purposes (FSP). FSP is in response to precise demand for training which necessitates focus on certain communication situations, and is characterized by urgency of the situation. FSP is the situation where the learners know where, when, how and why they have to communicate in French. The programmes of French oriented in the areas of specialization are located here. Only a detailed analysis of the demand and the needs of learners will enable one to determine if the needs of the

linguistic training are really related to the domain and when there is a problem with the specific linguistic content (Balmet and De Legge, 1992).

Each discourse is linked to its context of production (Specific contexts that are determined by the work domain in the case of FSP) and has its own characteristics that have to be analyzed so that it can be used again in a professional situation. It is important to remember that use of language varies according to the context. Thus, language use depends on the domain to which it is assigned in the society.

Enterprises look forward to training their staff not in general French but rather operational French in a professional context. Language teachers have to take into account these changes: whereas they were responding to general language needs, henceforth they have to turn towards professional language competences. In the teaching of FSP, it is the specific communication situation in which the learner will find himself that will determine the linguistic content to be taught. The need and desire to communicate emerges from a given situation and the form as a communication content is a response to the situation. In effect, learning of the language is as a result of influence of the society and includes socio-economic, cultural, political, educational and scientifically important events among others. This shows that there is need to establish a difference between 'learning a language' and 'learning to use a language' since language is an instrument of communication. FSP is therefore learning to use a language.

### **FSP and its pragmatic characteristics**

Learning of FSP subscribes to the pragmatic perspective. It is not only the ability to show linguistic capability but also the language use of a speaker in a particular communication situation. In this case, the teaching has a characteristic of usefulness. FSP is not teaching or learning of French but rather it is learning French for a precise use or for doing something. It is French to enable one work

and for the others to pursue studies (Tauzin, 2003).

A language that does not allow execution of precise tasks and which is not useful for development has its usefulness reduced. The question today is not only necessarily to know which French should be taught, but rather which competence. Language is no longer a knowledge that a learner should acquire but rather mastery of know how in a situation (Bertocchini and Costanzo, 1989).

Importance presently accorded to communication places the public and their needs in language realization in the centre of methodology edifice: this is functional French. Learners no longer learn a language for the pleasure of learning. They envisage a use. It is no longer teaching language but rather language for a job by using specialized terminologies and vocabulary for the particular job. It is therefore necessary to motivate the learners by showing them the benefits they can hope to get by their mastery of French. Offer and demand are linked to the language market, just as they are in other markets. In this case, the linguistic training program has to respond to the language needs of the learners. Taking into account the real communication needs of the learners allows integration of all types of functional activities in the language class.

The language needs of the learners are determined in relation to speech acts that they will need to accomplish in precise communication situation. At present, studies are being carried out on the specifics of teaching of foreign languages to adults. The learner occupies an important place in the training process. There is therefore need to analyze the learners and their language needs to determine the linguistic content that should be proposed to them. It is necessary to pick out morphosyntactic and lexical aspects of the language (French) saying that it is not only teaching of the French language but rather teaching how to communicate in French.

Identification of the language needs of the concerned learners is a prerequisite for the formulation of programs such as 'linguistic immersion and French improvement', including training in French for specialization, visits to enterprises, meeting with experts in the particular domain (French for Business, French for Tourism, Scientific French, Technical French). It should be noted that it is the nature of the language needs that dictates the specific linguistic training.

The expression 'language needs' refers to what is directly necessary to an individual in the use of the foreign language to communicate in his specific situation as well as that which he lacks at a particular moment for this use and which he has to overcome by learning (Cuq and Gruca, 2005). For training to take place there must first be information and that this information is of use.

Concerning the language needs analysis, it corresponds to the real preoccupation of the learner that is those that are related to what the learner will have to do outside the classroom with the French language.

The French language should play a big role in the development of Kenya. Due to this, it is necessary to come up with communication situations, participants, their status and their roles, the topics, speech acts and notions, learning aids and modes of communication. The list of words, presentation of morphosyntactic structures, phonetic rules, examples of intonation, spelling rules, and all elements that are used to describe a language as a form. These are the starting points of linguistic program descriptions.

If the learner is made aware that French as a foreign language can be used in topics taught in his/her other lessons, the learner will probably be conscious of the practical usefulness of the French language as a means of communication. The French language will thus be of practical use. The learner of FSP is required to ask for

information, services. He/she has to understand the answers given to him/her or listen to a conversation, and he/she will be able to read useful notices. More often, these speakers form a category of bilinguals of chance. Their use of French is occasional and is limited to the context where the importance of communication is relaying the message.

In the modern practice of teaching FSP, the objective to achieve is easily defined. It is formulated in terms of communication; that is to acquire more expertise than simple knowledge. The learner of FSP is no longer asked to formulate grammar rules rather he/she is asked to express himself/herself and understand others, either orally or in written. In all instances, the trainer should assist the learners to express themselves in French by taking into account the linguistic acquisitions. It is thus necessary to write down specialized vocabulary, sentences or responses that are the most useful.

But since communication takes place through language, it results in use of words, morphological and syntactic forms, structures, utterances, whereas language communication is essentially a phenomenon of exchange, intervention, action and interaction, negotiation which combines all these elements into discourses and texts (Richterich, 1985). Through this, language supposes not only to take into account speakers competence in general but also the way he/she uses it in concrete communication situations and in the society. The speaker adjusts his expressions in specific communication situations by use of different function words or language registers as dictated by the communication situation. Finally, teaching learners terminology related to their respective disciplines during their university or professional studies is one of the best guarantees of change however latent, of linguistic habits (Cabr , 1998).

### **FSP: a subset of French as a foreign language**

It is important to note that FSP is not a separate domain from French as a foreign language. It can be considered quantitatively as a sub-field of French as a foreign language, by determining what can be taught, and qualitatively, as the highest expression of communicative methodology. (Mangiante and Parpette, 2004). It is a specialized subset of the larger domain that is French as a foreign language. FSP is a linguistic training: it can be affirmed that every learner disposes, among the words of the general language, other words that are restricted to specialized areas. The FSP course in the chosen domain allows the student to acquire a technical vocabulary as well as mastery of the jargon used in a particular profession. The student therefore has the real advantage in his future search for employment. The orientation centered on linguistics considers the terminology as being part of the vocabulary of the language, and the language of specialty as a sub-system of the language in general. The terminology is related closely to the domain of specialty, therefore is part of specialized vocabulary.

FSP, which advocates for specialized communication, differs from general communication in two aspects: use of specific terminology and the type of written and oral texts that it produces. Use of normalized terms contributes to efficiency in communication between specialists. Specialized texts are characterized by conciseness, precision and adequacy.

### **State of FSP place in Kenya**

The current study was carried out in Kenya. As in all other African countries, Kenya has a large ethnic variety: 42 tribes. Each person from these tribes, in addition to his/her mother tongue, speaks English, Kiswahili and perhaps his/her neighbours' language. Each individual is thus bilingual or multilingual. To all these languages, is added a foreign language, and in this case, French. These ethnic groups are actively involved in nation building and due to this, they need

French to accomplish their task. They are in contact with foreigners from French speaking countries who visit Kenya. They also travel to foreign countries for various reasons such as studies, jobs, commerce, international co-operation, conferences, and workshops.

In general, the linguistic policy is defined by the choices made by those in power to regulate the correlation between the society and its languages. In Kenya, the reform policy and the opening to the outside world has contributed to manifestations of new demands for specialized linguistic training. The teaching of French as a foreign language is for sometimes marked by a strong development of training in FSP. Therefore, this was later progressively integrated into the teaching programmes and today, they are prevalent in many training programmes in French in various universities and professional institutions. This phenomenon contributes to the dynamism of the French language and allows its adaptation in different domains of knowledge.

The entry of foreign languages in the Kenyan education system does not go beyond the 1960s. First of all French and German, were fitted into the education system during the time when it was most stable and when the education policy was well grounded (Choka, 2004). French is studied in Kenya as a foreign language and it does not enjoy a particular francophone environment.

The French language is being taught in Kenya for the last 50 years (Alliance Française, 2006). Kenya possesses a well established network of institutions, curricular and extra-curricular for the advancement of FSP: Alliance Française, universities, professional institutions. FSP is increasingly present at higher levels in the tertiary education. To evoke the place of FSP in Kenya is to put into perspective the multilingual situation of this country where more than forty local languages exist along with French. Promoting French in Kenya is obviously in defense of the linguistic

diversity which is an asset for its development. Kenya is a turntable for Africa in general and for East Africa in particular. In this strategic position, Kenya needs French for its integral growth.

The question regarding the future of FSP, which is largely promising, in this era of globalization, is no longer beyond its players. They are in a position to work out diverse responses, propose strategies to adopt, come up with plans which will stir people into action, political actions, language use, and intervention towards social demands, media support and development of the French offer.

Today, teaching of FSP in colleges and universities in Kenya seeks to have what teaching of foreign language to adults has had for a long time. FSP has, without doubt its place in Kenya's linguistic space. Taking into account the usefulness of French, Kenya has adopted it for diplomatic links, free exchange of goods and movement of people, to assure contact services with the French world. The growth of the tourism sector has also contributed to adding value to the status of French. Preference of French as a foreign language has therefore flourished.

French has for a long time had a certain consideration in higher learning because it is the most taught language in many professional schools or technical colleges, training colleges for teachers and in the six public Universities (University of Nairobi, Kenyatta University, Moi University, Maseno University, Egerton University and Masinde Muliro University of Science and Technology, and their constituent colleges as well as in some private universities notably USIU(United States International University ), CUEA (Catholic University of East Africa), Daystar University, Baraton University of East Africa. In most cases, it is FSP which is offered in these institutions taking into account its importance in this era of globalization.

The current period in Kenya is more and more conducive to a reflection on the content of language for a specific public, as evidenced by the many events, seminars and publications on languages of specialties. This new scientific impetus is as a result of an increase in demand for courses and training in French for professional use. Internationalization of exchange, opening towards French markets and specialization in France has constituted a lot of motivation for a new group of more demanding learners, having learnt many languages before registering in the French course and demanding shorter courses, more goals oriented, towards results oriented professionals.

Considering the wishes of the public and individuals requesting for linguistic training led to a new interest of analysis of needs, in the teaching of languages. We thus speak of language needs of a group, public, individuals and the consideration that an in depth analysis of these needs will allow a better adjustment of the linguistic training requested in relation to globalization.

Everywhere, today, the society is undergoing vast changes. It is at a fast rhythm that scientific discoveries are giving us a more detailed and in depth understanding of the world that surrounds us and the industries founded on research that continue to grow apply this knowledge more rapidly to all domains of life. Not only have individual trips and transport of merchandise transformed mobility, even at the international level but exchange of ideas and information has practically become instantaneous and unlimited geographically. FSP has a big role to play in Kenya, in these aspects.

FSP continues to give an added value on the context of internationalization in socio-politico-economic exchange. Students, researchers, executives and directors from foreign countries experience both in class and place of work, the need to access intricacies of the French language so as to

understand the thoughts being expressed. In order to speak at a congress, at a conference or seminar, to write a scientific text in French, interact with somebody in a particular domain, one has to adhere to specific rules.

FSP has become indispensable in Kenya, for example, to respond to the needs of the tourism industry which has already announced an increasingly important role in the country's economy. With the aim of providing qualified staff, the Kenyan government decided, since 1969, to integrate learning of foreign languages, among others, French, in the training designated for students of hotel management at the Kenya Polytechnic Nairobi. In 1975, this training was extended to Utalii College (Choka, 2004). From then on, this college confers certificates and diplomas to students who have learnt French be it in hospitality, restaurant or travel agency.

Each year, approximately 200 students complete their studies at Utalii College, after having learnt French for two years. Since 1975, the year when the college began, about 3000 people trained in FSP, contribute in terms of communication between the French or French speakers and Kenyans at the level of tourism, in the hotel industry and restaurants. Many tourist agencies, hotel institutions and restaurants use this argument for publicity reasons. Hotels and other tourist establishments are the main employers of these finalists. It is worth noting that Utalii College also offers a linguistic training program for personnel already working in these institutions.

Many institutions in Kenya, public and private, with the aim of responding to the market requirements, offer French for International Relations and Diplomacy, Secretarial French and Public administration, French for business, French for journalism, medical French.

With the rise of globalization, societies are faced with a new international push,

necessitating development of their services in different countries. FSP, in regard to globalization, emphasizes the place of French in the world of work. The globalization phenomenon is a driving force for FSP.

Growing internationalization of daily life requires taking into account communicative capacity linked to cultural mastery. The time for linguistics is in the process of being achieved because the place of languages in societies is in itself in the process of changing (Porcher, 1995). At present, functional French is taking up a place of choice.

In the last centuries, linguistic needs of learners have changed. Developments in the technological world have had a big impact on all aspects of life. With the advent of globalization, the need for FSP is unavoidable.

We are in a culture differentiated by types of practices, disciplines, specialties and jobs. However, the dynamics of globalization presently taking place tend to disturb the distinctions made in the past. Learning one or more foreign languages is no longer contestable for individuals who consider themselves cultured, but professional obligation related to carrying out of various jobs.

It is important to closely examine what is becoming of communication of specialty and specialties in the process of integration of the present globalization: what are the significant changes brought by globalization in communication of specialty? How can these changes be integrated in the teaching of FSP in Kenya? Every activity is anchored in a centre and access to the culture could be done well today in a society accepted by the way of a practice in a domain of specialty and not only by way of the general or of the basics, with its values of reference and its practices.

The main effect of globalization goes beyond general increase in exchanges, a

deconstruction/reconstruction of limits between specialties and in relation to the general culture (and language). The cause would be the diffusion of technologies and intensifying of exchanges, with regard to culture. In regard to exchanges, what concerns us is communication of specialty in the teaching of languages in general and FSP in particular.

The term globalization refers to ‘an extension of an activity, of a technical, of a problem of a language (among other examples) at the level of the planet,’ then ‘the multiplication and intensifying of interdependences at the world level’ and also ‘a process.... an englobing organic movement’ (Revue Mots and Mars 2003). In this way, the uniform practice of activities such as in medicine, chemistry, architecture, computer is spread over the whole planet. It is the same for tourism, banking, finance, international relations, teaching of languages.

Languages have become goods of use, socially, marketable and professional, which are of interest to learners who only want to understand and be understood. Mastery of linguistic tools is certainly a significant characteristic of efficacy of a strategy of communication. It is worth noting that the present Kenyan context is favorable with the realization that mastery of French is considered a real professional competence in the cadre of professional assertion. It is necessary to valorize mastery of French as it is a factor of personal development and socio-economic promotion.

Learners of FSP in Kenya need to acquire practical linguistic knowledge that can directly be used in their cadre of employment or profession; this is to say French should be taught so as to be able to do something else with it and not simply for the sake of learning it. They learn FSP for a specific use in specific contexts. In other words, being conscious of the usefulness of lessons in FSP is a motivating factor for these students.

## **Conclusion**

Kenya is in the process of re-inventing itself and addressing economic and social recovery in which the French language could become useful. As a language of exchange and exposure, French could take its place in the many sectors of life. In summary, there is thus a real interest in learning FSP today.

Society, along with its educational structures, is evolving rapidly. With time, motivations change and the needs become more precise or are transformed. The French language will only remain alive in Kenya if it responds to the needs of the society in general and to those of the learners in particular. The domain of usage of a language is motivated by the nature of the social structure and is determined by the economic, political and ideological forces among others. Consequently, these forces act on the language behavior of an individual. It is today opportune to ‘live French’ everywhere in the world: language of interpersonal and intercultural dialogue, language of communication, of solidarity and for co-operation, scientific and technical language. FSP, faced with globalization should emphasize on the place of French in the world of work. It is through this that the vitality of FSP can be manifested in Kenya.

If we realize that Kenya has an economy that largely opens up to the outside world, it goes without saying that in these exchanges, the francophone countries would take their rank more easily if there are speakers of the language on the ground. It is certain that in this country which is undergoing transformation, hence new priorities will be needed. For instance, those which will ensure the country is not cut off from the rest of the world.

In the present context, FSP has all the chances of becoming an important language of exposure and exchange.



## References

- Balmet, S. E. and De Legge, M. H.** (1992). *Pratiques du français scientifique*, Hachette, Paris.
- Baylon, C. and Mignot, X.** (2003). *La communication, les outils et les formes de la communication : une présentation méthodique et illustrée*, Editions Nathan; Paris.
- Bertocchini, P. and Costanzo, E.** (1989). *Manuel d'autoformation à l'usage des professeurs de langues*, Hachette, Paris.
- Cabre, M. T.** (1998). *La terminologie, Théorie, méthode et applications*, Arman Colin, Les Presses de l'université d'Ottawa, Ottawa.
- Choka, M.** (2004). *Formation des enseignants de français au Kenya. Cas de Kenyatta University*. Thèse de doctorat inédite. Université de Franche Comté. Besançon.
- Cuq, J. P.** (2003). *Dictionnaire de didactique du français langue étrangère et seconde*. CLE International, Paris.
- Cuq, J. P. and Gruca, I.** (2005). *Cours de didactique du français langue étrangère et seconde*. Presses universitaires de Grenoble, Grenoble.
- De Sainte L. P. and Goetz, C.** (2008). *Faites le bilan de vos compétences*, Groupe Eyrolles, Paris.
- Galisson, R. et al.** (1980). *D'hier à aujourd'hui la didactique générale des langues étrangères*, Paris, CLE International.
- Lehmann, D.** (1993). *Objectifs spécifiques en langue étrangère* ; Hachette, Paris.
- Mangiante, J. M. and Parpette, C.** (2004). *Le français sur objectifs spécifiques : de l'analyse des besoins à l'élaboration d'un cours*, Hachette, Paris.
- Porcher, L.** (1995). *Le français langue étrangère. Emergence et enseignement d'une discipline*. Hachette, Paris.
- Renard, R.** (1976). *La méthodologie SGAV d'enseignement des langues. Une problématique de l'apprentissage de la parole*. Librairie Marcel Didier, Paris.
- Revue Mots and Mars.** (2003). *Mondialisation(s)*, Editions ENS, Lyon.
- Richterich, R.** (1985). *Besoins langagiers et objectifs d'apprentissage*, Hachette, Paris.
- Tauzin, B.** (2003). In Outils et pratiques du FOS dans l'enseignement, la formation d'enseignants, les examens et l'édition, Table ronde in Y-a-t-il un français sans objectif(s) spécifique(s) ?, *Les Cahiers de l'ASDIFLE*, No.14.

# Evaluation of Textual Competence of Kenyan Students Learning French as a Foreign Language

By

Ngoy Mwilambwe<sup>1\*</sup>, N'diabou Sega Touré<sup>2</sup>, Muteba Kazadi<sup>3</sup>

*1; Department of French, Maseno University, Maseno, Kenya*

*2; Université Cheik Anta Diop de Dakar/Sénégal*

*3; Masinde Muliro University of Science and Technology, Kakamega, Kenya*

*\*Corresponding author: [mwilambwe@hotmail.com](mailto:mwilambwe@hotmail.com)*

---

## Abstract

This article presents an evaluation of textual competence of Kenyan University students pursuing the bachelor degree in French. This research offers information on the skills acquired on textualisation as it is at the completion of the undergraduate studies. Having been carried out at the transition period between the University and work market, this evaluation assesses knowledge and know how required in writing a narrative text. Textualisation in this context refers to the textual competence manifested in the quality of linguistic, pragmatic and communicative knowledge. It is in light of these parameters that the study assesses the writing expression level of the graduands.

---

## Introduction

During training, an undergraduate student of French as a foreign language is often in contact with a large number of texts in French, of various forms, that she/he writes or uses to obtain information, to explain himself, to narrate, to communicate or accomplish various tasks. This familiarity with texts tends to make the student forget that a text is not a triviality, but as a result of learning over a period of time and a long experience in composition as well as in reading. Although it is apparently easy to recognize a text format at first sight, understanding and defining it with precision is difficult. What distinguishes a series of sentences making a text from one, which is not? What are the attributes of a 'good' text?

What is it happening in the mind of a writer in action? These questions prompted Fayol (1991) to consider that the text, as a process of writing, implies various factors related to the product (text), to composition, to the psycholinguistic status of the writer and to the teaching. According to Rück (1991) etymologically, the word 'text' is derived from the Latin word "*textere, textus*" which means "to weave", or "fabric", referring to that which is spun or woven. Other than this etymological point of view, a text is comparable to a fabric where "threads" are interlaced. The reflections of Fayol and Rück are well captured in the following definition: a text is thus "a sequence of structured and coherent sentences transmitting a message in a particular context and accomplishing an intended communication" ([www.lepointdufle.net](http://www.lepointdufle.net)).

In clear terms, contrary to arbitrary juxtaposition of sentences, a text is based on principles of coherence and organization, from which it draws its form and function. These constraints cannot be observed without coherent linguistic units: in consequence, a text should not contain a word, which, once removed, would not affect the entire sentence or compromise the whole structure. To meet these expectations, a well-trained writer should be a “competent writer” in French or any other language: are the graduands of bachelor degree in French as a foreign language fitting this profile?

### **Textual competence**

Rück views textual competence as “a set of skills to constitute a functional coherence and textual delimitation (in the active and receptive sense), domains in which thematic and typological points of view have a role to play.” Dabène (1990) shares the same opinion and according to him, textual competence is in the cadre of know-how which refers to operational and observable manifestations of knowledge. This is a generic know-how originating from activities that have been lived or produced and which the researcher refers to as textual know-how. No doubt, the scripter’s work is perceived, as dynamics of mobilization and integration of competences of knowledge as well as those of know-how, among them the following: general competence in writing, linguistic and pragmatic competence. In the learning context of French as a foreign language, these competences are acquired through various activities and practice in writing in class.

### **Writing in the academic context of Kenya**

Despite autonomy, as far as conception of academic programs is concerned, all the universities have the same objectives for the teaching of French: communicate in good French, express oneself fluently in the language, and make efficient usage of competences acquired in the language sciences. It appears that these objectives aim at training of the competences by acquiring French language, which can be evaluated

periodically. Concerning written French, operationalization of these objectives is done progressively through the lectures whose activities take into account the language needs, practice in writing and means of access to knowledge (reading, composition exercises and linguistic context).

### **Language needs at the university**

Language needs at the university level are many and various. Writing as well as oral practices are the key to success in the French department where more examinations are largely written. In fact, the academic context of learning and the nature of course and relationship with the lecturers require that the Kenyan learner becomes *ipso facto*, a writer of this language. He is required on a daily basis, to show his capability in writing by way of taking notes, summary making, narrations, descriptions, portraits, reports: It is from these exercises that the learners practice to freely write texts. These are a reflection of a historical and cultural process that has slowly matured and which evokes academic experiences of the learners as well as the criteria of the assessment he went through. These experiences have explored, over a number of years, the cognitive resources and the language know-how necessary for textualization.

### **Practice of writing**

At the university, our attention has always been drawn to the technique of *note taking*, very common in classes of French as a foreign language; this practice must have a certain impact on production of texts by the students. From the foregoing, the following question should be asked: how can we reconcile “*notes*” to “*taking*” on a background of spelling and morpho-syntactic deficiency? In spite of the answer to this question, the students have to find a strategic way of meeting the challenge; thus, the practice continues to be in use by Kenyan students during each lesson and it appears to be the most interactive practices in writing.

In the cadre of teaching of FLE as perceived by the Gabillet of Montbron (1998), this technique, which is part of a progressive

linguistic acquisition process, allows selection and classification of the dictated main ideas or the written ones before taking notes. From a dictation, (an uttered writing) and an oral or written aid, the lecturer uses this technique to sensitize learners on textual organization: he uses the “reading comprehension” competence in order to enable the acquisition of another, the “production competence of a structured writing” (through planning of ideas, wording, summary). This technique, which is not, as such an objective of training for the Kenyan students of French as a foreign language, plays a role however small, in the acquisition of scriptural competence and on various aspects of a text.

### **Reading**

Among other academic practices in writing experienced in class, we can recognize reading of text and literary works, elocution exercises from selected essays or presentation of reading reviews of books. Given that, a quarter of the undergraduate course is constituted by literature courses, analysis of classic literary texts is done with the aim of modeling the texts. Thus, reading of these texts should allow the students to construct a mental model of the process necessary for writing. On the other hand, these texts constitute a linguistic immersion and a source of inspiration to guide the writing learner.

The lecturer therefore has to offer a reflection paths, aids and writing models with the aim of making the students performance in writing as close as possible to that of writers or experts. It is in this way that reading and writing interact in the construction of learning and scriptural competences, not forgetting that the proximity relations between reading and writing is real. Isn't it true that it is the same body of linguistic concepts that the two share and which the writer should in each case master? In responding to this question, Jolibert and Gloton (1975) designed a matrix that has seven shared levels between reading and writing:

- Context: what is the mode of transmission of the text to the reader?
- Pragmatic situation: Who is writing to who? What is the aim? What is the subject?
- Type of writing: Types of texts, textual aid.
- Super structure: Articulation of textual components.
- Linguistics of text: Connectors, topic/focus, link enunciation indicators, coherence and text progression.
- Linguistics of the sentence: Order of words, cohesion, syntactic relations.
- Semantic and spelling microstructures.

### **Composition exercises**

They are exploited as communication situation in which the learners exercise themselves to write for textual purposes. The most distinctive are exercises in which the learner is asked to write the summary of books read with the aim of training him/her to identify important issues of the texts and to develop the practice of being concise and of contraction of the text. Among these communication situations are also writing of monographs during their university studies of French as a foreign language. This is different from other exercises in the sense that they initiate the learners to the rules of academic composition in use at the university, a use that is confirmed in the writing of a thesis at the master's level, in French as a foreign language. This exercise reveals the complexity of academic discourse, in which pedagogical needs are larger than the contents of general French.

### **Contextualization**

In relation to linguistic context or “*cotexte*”, our experience in FLE classes in Kenya shows that due to grammatical deficiency, wrong punctuation or stylistic contraction that characterizes the learner's compositions, only the context assists in understanding of the texts. The reader (teacher, researcher, and learner) who has to read or correct these writings is often put to the task of interpretation and often asks him/herself this

question recurrently “*What did he/she intend to say in writing this sentence?*” This question implies that the understanding of learner/writer’s work cannot be done only by referring to the linguistic sense of the sentences or words, which are in fact only premises and from which the reader should infer the exact meaning of the sentence. These sentences, apart from the meaning of the words, have certain aspects of the context (such as punctuation), which play the role of the pragmatic complement in the FLE classes. This therefore plays the same role as the linguistic meaning in communication, which are in fact the mobilization process, which is coded or inferred (Grice, 1979).

### **Statement of the problem and Research Questions**

#### ***Statement of the problem***

All these practices of writing should, among others, aim at improving enunciation and structuring of the elements of a narrative text. However, there are evident cases of inadequacy between knowledge and know-how. Some learners have a very good knowledge of the language and in practice, a very low textual and communicative ability. This inadequacy seems to be as a result of a bad transition between teaching/learning of French to teaching/learning in French. On the hand, all issues related to written French at the university seem to be linked to this transition, which cannot have meaning unless there is a respondent to the learner. This problem is more serious today when we try to evaluate learner-writers who are in the transition period between the university and the job market.

#### ***Research Questions***

The study was guided by the following two research questions:

- a) At the end of undergraduate study in FLE, are the learner-writers capable of writing showing vivid textual competence?
- b) What is the level of textual competence in French, attained by these learners?

### **Methodology**

#### ***Methodological modalities of the study***

Our research on the quality and expanse of the competence of Kenyan students of French as a foreign language to communicate through texts, took into account the following methodological considerations:-

- a) All the learner-writers are not equal before scripting is concerned, and this inequality is a characteristic of textual competence: there are no two users of a language, native speakers or learners of FLE, who have exactly the same competences and who develop them in the same manner.

Consequently, by discriminating the different learner-writers, we avoid to evaluate them or even analyze the written texts in relation to an ideal writer, but according to their own intrinsic variability (Dabène, op.cit). This intrinsic variability can be observed both extensively and intensively. According to this author, extensive variability explains the disparity in the unequal mastery of different components of textual sub-competences by all the writers. There can be lack of symmetry in the acquisition of different textual sub-competences and also in each one of them; “this ‘lack of symmetry can, at the extreme, result in the absence or non-mastery of this or other component” (Dabène, op.cit). Intensive variability, on the other hand, refers to the level of mastery of the components, which can vary from one writer to another.

- b) We opted to use a criteria approach bearing in mind that this kind of approach will eliminate any improvised evaluation methods of the written work. We used a modified version of the grid used by research program CAMPUS (*Coopération africaine et malgache pour la promotion universitaire et scientifique*) as our evaluation tool (Holtzer, 2002). The choice was not made haphazardly: this grid has a detailed structure of textual

cohesion that has already been experimented successfully elsewhere (in Guinea Conakry at the primary school level). Technically, it has the criteria that can be observed and verified through qualitative and quantitative indicators. These characteristics enabled us to evaluate the quality of the written work of a learner-writer without it being necessary to compare it with others; the learner is appraised solely in relation to his ability or competence.

- c) The Cronbach's coefficient ( $\alpha$ ) was calculated by using the *Statistical Package of Social Sciences* (SPSS) program in order to assess the homogeneity and internal coherence of criteria in the said grid, as well as that of the marking by the four evaluators. In the two instances, the alpha coefficient attained was of a satisfactory level of 0.85 for the homogeneity of the four evaluators and 0.76 for the internal coherence of the criteria.
- d) The observations made from the learner's written work have no etiological value because they do not make it possible to explain the cause of presence, absence or greater or less mastery of the particular aspect of scriptural competence.

### ***Study population***

The study population of this research is constituted by 60 (sixty) 4<sup>th</sup> year undergraduate students registered for the academic year 2009/2010, studying French as a foreign language. They were drawn from public institutions which offer a complete bachelor degree course and have an experience of more than years in teaching the undergraduate courses: Maseno University, Kenyatta University, Moi University and University of Nairobi. These students had learned French consistently for 4 years in secondary school and for the same period at the university. However, learning of French began at the age of 14 years and was preceded by 3 or 4 vernacular languages and/or other languages for communication.

### ***Corpus of the study***

To evaluate the competences involved in the written work, we found it useful to work on the narrative texts. Produced under ideal conditions, they perfectly take into account the said competences and are declined towards a narrative outline. The choice of this type of text is also justifiable due to the fact that it is culturally more familiar to African students in general and Kenyan students in particular. From this point of view, writing a narrative text means telling a story in writing, reporting events that one has undergone or those that one has heard being talked about.

With the aim of evaluating the learner's competences and having more information to answer the research questions, we resorted to the technique of "Induced constraints text" (*texte induit avec contraintes*) to collect the data. According to Tagliante (2005), this technique enables drawing up the activities of the written work where the evaluation is appropriate to the intended objective and where the instructions given play an important role. The instruction clearly states the constraints set out. In conformity with this requirement, the students were asked to write a text of their own choice: this frequent academic exercise is an activity of a relatively free expression which allows the syntax maturity to freely take form in the writing of a narrative text.

On the other hand, the texts that we received explored four major themes, which include the 2007 post election violence in Kenya, different events undergone or reported, tales as well as reconstruction of news narrated by a third party. As stated clearly by Adam (2008), these texts were heterogeneous; we evaluated texts that were dominantly narrative in nature but contained descriptive sequences as well as texts that were dominantly descriptive but had narrative sequences. In our opinion, this is due to the dual role played by the writer who is both the narrator and actor.

**Evaluation grid for textual competence**

It is obvious that to write a text, one has to be endowed in the first instance, with certain scriptural competences. These are many and various and include referential competence, socio-cultural competence, general competence in writing, linguistic competence, pragmatic and communication competence etc. The grid (see Annex) evaluates the last three, with each one of them being evaluated using a certain number of criteria in descriptive terms:

- a) **General competence in writing** takes in account the following activities: presentation of the text, the written form, punctuation, scripturality. Mastery of this competence is evaluated in terms of success of the marked indicators of the criteria 1-6 of the grid.
- b) **Pragmatic and communication competence** refers to the capability of writing a narrative text. Mastery of the type of competence is in relation to the criteria 7-13.
- c) **Linguistic competence** is observed through the following three components:-
  - Linguistic competence in vocabulary takes into account spellings, appropriate vocabulary, rich and devoid of literal translations. Mastery of this competence depends on the success of marked indicators of the criteria 14-16.
  - Linguistic competence in morphology refers to gender and number of words, verbal constructions, conjugations,

agreement between subject and verb and other types of agreement. The mastery of this competence is measured by success in the criteria 19,20,23,24,25,26,27 and 28 of the grid.

- Linguistic competence in syntax refers to the linearity of a simple sentence and that of a complex sentence. Mastery of this competence is measured by success in the indicator 21 and 22 of the grid.

Except for criteria 17 and 18, which aren't part of the study, the grid evaluates each criterion in a binary form as follows: mastered competence (+) or non mastery (-). The researchers of the CAMPUS group suggest that mastery (+) can only be given when the writer shows proof of mastering globally a given indicator. As it transpires in the mind of the designers, we consider this *global mastery* as results of a realistic approach in accepting 'a small level of errors' (Holtzer, op.cit) taking into account the context in which French was learnt and evaluated as a foreign language in Kenya. Mastery of an indicator (+) is attributed to a description when, as a whole, the text shows proof of global mastery of it. In our case, this means either appreciating qualitatively the linguistic indicator, or quantitatively enumerating it in order to compare the occurrences observed with the expected ones.

**Scoring scheme evaluating levels of written expression**

**Table 1: Scores univers**

Level of Mastery	Global Criteria of Evaluation
Level 0 Absence of mastery	Not possessing in totality The criteria of level 1
Level 1 Unsatisfactory mastery	Possess all the criteria 1, 5, 7, 8, 9
Level 11 Satisfactory mastery	In addition to level 1, possess 5 of the following: 3, 4, 10, 11, 14, 19, 20, 26 Possess the minimum criteria 12, 15, 21, 23
Level 111 Very satisfactory mastery	In addition to level 11 possess 4 of the following criteria: 2, 6, 13, 22, 24, 25, 27, 28

Table 1 summarizes the allocation of “scores univers” obtained by every writer to each level of written expression in French. It is in reference to the “*scores univers*” obtained that the writer was graded. The advantage of the “scores univers” is that it allows a description of the competence of the subject not only using one score, but also by an aggregate of all the scores, characterizing the potentialities of the writer ([www.irdp.ch/édumetrie/lexique](http://www.irdp.ch/édumetrie/lexique)). In this research, we proceeded by a gradual and progressive evaluation: we assessed the scoring of level 0, then I, before gradually proceeding to the next level.

These “*scores univers*” were evaluated in form of a continuum, such a way that the degree of the level of mastery of the textual competence was from level 0 to level 3: absence of mastery (level 0), unsatisfactory mastery (level 1)

satisfactory mastery (level 2) and very satisfactory mastery (level 3). It is worth clarifying that level 0 indicates a non mastery of the basic elements of the language; level 1 corresponds to very rudimentary knowledge; level 2 is a sort of threshold level; it attests a mastery that is “just sufficient”; level 3 indicates a good linguistic and textual mastery. Each level except 0 and 1 is the resultant hierarchy of a selection of criteria made from among the 26 (except for criteria 17 & 18) that are contained in the grid.

## Results

### *General Competence in writing*

Interpretations of the data relative to this competence are summarized in table 2 below:

**Table 2. Mastery or non mastery of the general competence in writing**

criteria	C1	C2	C3	C4	C5	C6	Totals
<b>Non mastery</b>	-	8 (13%)	3 (5%)	1 (2%)	-	-	<b>12 (3%)</b>
<b>Mastery</b>	60	52 (87%)	57 (95%)	59 (98%)	60	60	<b>348 (97%)</b>
<b>Totals</b>	60	60	60	60	60	60	<b>360</b>

**C-2** = Use of accents in the text #

### Key

**C-3** = Punctuation#

**C-4** = Capital letters #

**C-5** = Breaking of words #

**C-6** = Segmentation into paragraphs

The following observations can be drawn from Table 2: 52 out of 60 candidates, 87% of our sample are able to correctly write accents on the words when they write a text whereas 95% of them (57 candidates) are able to punctuate the text in an acceptable way. Whereas only 98% (59 candidates) respect the use of capital letters after a full

stop, all the candidates (100%) of this sample were able to write a text that was legible to divide it into paragraphs and to break the words correctly. As a whole, it is obvious that 97% of the students satisfied the criteria for this competence; based on these results, we can empirically establish that the majority of our candidates have globally a mastery of this competence.

### *Pragmatic and Communication competence*

The data related to this competence are presented in the table below:-



**Table 3: Mastery or non-mastery of the Pragmatic and communication competence**

Criteria competence	C7	C8	C9	C10	C11	C12	C13	Totals
Non mastery	1 (2%)	2 (3%)	3 (5%)	10 (17%)	41 (72%)	15 (25%)	27 (45%)	99 (24%)
Mastery	59 (98%)	58 (97%)	57 (95%)	50 (83%)	19 (28%)	45 (75%)	33 (55%)	321 (76%)
Totals	60	60	60	60	60	60	60	420

**Key:**

**C7** = Writing Comprehensive text#

**C8** = Understanding the instruction of the composition #

**C9** = Tell a story #

**C10** = Know how to introduce and conclude a text #

**C11** = Know how to use indicators of time to show progression of the story.

**C12** = Know how to use the appropriate tenses of narration (*imparfait, passé composé*)

**C13** = Know how to coordinate the words in the text.

The evaluated candidates have a global mastery of pragmatic and communication competence: among them 76% has a sufficient mastery of this competence against 24%. In regard to criteria, we realize that 98% of the students are able to produce a comprehensible text, that is to say that the text content could generally be understood by the reader. Moreover, 97% of the sample can follow the instruction of the composition, which is an indication that they have understood the task before them.

Furthermore, we observe that among them, 95% and 83% of the students are able to narrate a story and to introduce as well as to conclude a narrative text respectively. Therefore, the students are generally capable of reporting actions that constitute a story, to introduce and conclude it. This capacity is being illustrated in reporting events or African tales narrated to them by a third party or others events; in this regard the writers are able to do the same following a scheme of five steps. Thus, an in depth reading of these texts reveals the existence of elements relative to the initial situation of the story, to disruption, to the development, to the resolution and conclusion or moral of the

story. This observation is in line with the findings of Ogutu (2010) who states that the Kenyan learner of FLE acquires the narrative skills prior to his contact with French language. This is not surprising more so because, as is the case everywhere in Africa, the socio-cultural Kenyan context is the heart of the story telling tradition and from which these competences can be build.

We also observe that 75% of the writers are able to use effectively the tenses of narration (*imparfait* and *passé composé*). This outcome contrasts with the statistics from KNEC (Kenya National Examinations Council) report on written French in the years 2005, 2007 and 2008. KNEC reported that, in composition writing, the learners at the end of the secondary education were not able to correctly use *passé composé* and *imparfait*. These are the same students we are evaluating in the present study, four years later; as it appears now, there is a great improvement in the use of *passé composé* and *imparfait*. In our opinion, the pedagogical training obtained at the university appears to bear fruits and is very useful in this domain.

Concerning the coordination of words expressed through the criteria (C13), the results indicate an average mastery as only 55% of the candidates do it correctly, compared to 45% who have no mastery. Taking into account the number of errors accepted in this evaluation, we are of the view that this average performance is more of an indicator of the difficulty involved than that of mastery. In this regard, we observed that the candidates had difficulty in textual cohesion because if the conjunctions of coordination ‘*et (and)*’ to a small extent *ou* (or) and ‘*mais*’ (but) are the most used, contrary to *maintenant* (now), *ni* (neither) and *car (because)*, which are inexistent. On the other hand, in instances where they are present, they do not link up the elements of the same grammatical nature as is required in grammar and textual cohesion. This observation is closely related to the one made by Chokah (2003) in which essays of finalist students of Kenyatta University (future teachers of French) show “juxtaposition of sentences without any links between them”.

because only 28% of them were able to use indicators of time to express the textual progression of the story. This criterion involves use of connectors of time as articulation of thematic progression. Whereas as it is one of the main mechanisms of narrative textualisation, temporality has two gaps in the corpus: insufficiency and irrational use of connectors of time. Evaluated at 35% of all the connectors used in the corpus as a whole, only two indicators of time show chronology of events and these are *avant que* (before) and *après que* (after). All the other indicators of time appear sporadically, in environments incompatible with their roles. Such an improper use of connectors of time is symptomatic of lack of knowledge of their role in textual cohesion. Degand and Hadermann (2008) also made this observation in his comparative study between the Dutch and French speakers on the use of connectors in French. The improper use or over use of connectors in FLE could be explained by difficulties in planning and structuration experienced by writers in a second or foreign language.

Finally we observe that only one criterion (C11) was not mastered by the students

### *Linguistic Competence*

#### **A. Linguistic competence in vocabulary**

**Table 4. Mastery or non mastery of linguistic competence in vocabulary**

Criteria	C14	C15	C16	Totals
<b>Competence</b>				
<b>Non-mastery</b>	35 (58%)	8 (13%)	43 (72%)	<b>86 (48%)</b>
<b>Mastery</b>	25 (42%)	52 (87%)	17 (28%)	<b>94 (52%)</b>
<b>Totals</b>	60	60	60	<b>180</b>

**Key:**

C-14 = Few usage errors #

C-15 = Vocabulary used is appropriate #

C-16 = Vocabulary #

In interpreting Table 4, we observe that 52% of the assessed writers have generally a lexical mastery of linguistic competence of vocabulary. Furthermore, 58% of them write their texts with 'few usage errors'. This criterion is related to the lexical and grammatical orthography. The proportion between the total number of these errors and total number of words (www.pedagonet.com) establish a ratio of one error in 7 words. This seems to be directly proportional to the length of the text: when the text has many words, it has a tendency to harbor more errors. This lack of reference to the French norm can be explained by the impact of dominant French/English bilingualism, which characterizes the Kenyan learner of FLE; therefore, they write French language with English structures in their mind. In the same context, the 2005 KNEC report observed then that most students of this group, which constitute the sample of the current study, had already difficulty in spellings. In his part, Kilosho (2011) has analyzed the errors made by students of Kenyatta University in Kenya, he found that instead of facilitating the understanding of French expressions borrowed from English or vice versa, the official language of Kenya appeared to be an obstacle in acquisition of semantics and spelling of French language at the University.

Although 87% of the writers make use of the appropriate vocabulary as shown in their

success in criteria (15) of the table above, their success is limited because only 28% of the students show proof of having rich vocabulary. The weakness on this performance shows a deficit in vocabulary which the students try to overcome by using a certain subterfuge vocabulary. Thus, due to lack of sufficient stock of vocabulary, the students turn to use either anglicisms or words with English connotations or switch homographs despite their different meanings in the two languages. More interesting is the way the writers try to overcome this difficulty in turning to the technique of morphological derivations in an arbitrary manner. The following sentences extract from the corpus illustrate this tendency of wording: the writer adds either to a wrong radix a correct affix (e.g. *habiments, applaudiser*) or puts together a correct radix with a wrong affix(e.g. *villageur, les annonces*) or sums the two wrongs(e.g. *médicins, malheurment*).

#### **B: Linguistic competence of morphology**

From Table 5, we observed that 79% of the students have a global mastery of linguistic competence of morphology against 21% who have no mastery. As regards to the criteria, 82% of the writers have a global mastery of the rule on gender of words whereas 93% of them master globally the rule of plural form of words.

**Table 5. Linguistic competence of morphology**

Criteria	C-19	C-20	C-23	C-24	C-25	C-26	C-27	C-28	Totals
<b>competence</b>									
<b>Non mastery</b>	11(18%)	4(7%)	7(12%)	17(28%)	1(2%)	21(35%)	22(37%)	16(27%)	<b>99(21%)</b>
<b>Mastery</b>	49(82%)	56(93%)	53(88%)	43(72%)	59(98%)	39(65%)	38(63%)	44(73%)	<b>381(79%)</b>
<b>Total</b>	60	60	60	60	60	60	60	60	<b>480</b>

**Key:**

C-19= Gender of nouns mastered#

- C-20= Number in words is mastered#
- C-23= conjunction in pronunciation#
- C-24= conjugation known in writer #
- C-25= Mastering of subjects. Verb agreement#
- C-26=correct conjugation of verbs#
- C-27=text shows mastery of difference between infinitif and past participle
- C-28=mastery of difference between infinitif and past participle.

Despite the confusion in applying the endings of verbs, 88% of writers globally know the conjugation of verbs in their pronounced forms; only 72% among them globally know the conjugation of verbs in their written forms. Furthermore, in as much as 98% of the writers globally have a mastery of subject/ verb agreement, 65% of them

only are able to make verbal constructions correctly. 98% of this population is capable of differentiating infinitive mood from past participle. However, to make an agreement between an auxiliary “*être* (to be) or *avoir* (to have) only 83% of them were able to do it correctly.

*Linguistic competence of syntax*

**Table 6. Linguistic competence of syntax**

Criteria	C-21	C-22	Totals
<b>competence</b>			
<b>Non mastery</b>	1 (2%)	41 (68%)	<b>42 (35%)</b>
<b>Mastery</b>	59 (98%)	19 (32%)	<b>78 (65%)</b>
<b>Totals</b>	60	60	<b>120</b>

**Key:**

**C-21:** Mastery of a simple sentence

**C-22:** The text includes complex sentences that are generally mastered.

Table 6 indicates that the majority of the students under study (65%) have a global mastery of this competence. Going by the criteria, when 98% of the writers have a global mastery of structures of a simple sentence, 32% of them globally have a mastery of the structures of a complex sentence. The poor performance in writing a complex sentence by the students can be a translation of the difficulties the learners encounter in organizing the constituents of juxtaposed, coordinated or subordinate propositions in the midst of the sentence. In the same line, sequence of tenses is also a major difficulty which distorts the links between the constituents of the sentence.

In summary, the writers have mastery, at some extend, the components of linguistic competence. Nevertheless, despite the global mastery, the students write texts riddled with mistakes, containing a less rich vocabulary tarnished with a less mastery of the complex sentences. Whereas they are as a result of Linguistic competence, the gaps are interdependent. We also observed among others that are difficulty in spelling for a number of the learners. They are as a result of non acquired linguistic competence, which leads to errors in spelling: non mastery of syntax, limited individual vocabulary that is poorly structured and dependence on English to write French language. Without these basics which constitute fundamentals of a complex

sentence, the writers found it difficult to make use of them in order to express themselves appropriately using narrative texts.

**Level of written expression**

The aggregate of the *scores univers* obtained by each writer enables us to classify the 60 writers of our study population in four

levels of written expression as shown below:

**Table 7. The level of written expression**

Levels	Writers	Totals
Level 0	S2, S43, S51	3
Level (I)	S22, S26, S35, S53, S60	5
Level (II)	S1, S6, S9, S20, S21, S25, S32, S38, S39, S44, S46, S47, S50, S52	14
Level (III)	S3, S4, S5, S7, S8, S10, S11, S12, S13, S14, S15, S16, S17, S18, S19, S23, S24, S27, S28, S29, S30, S31, S33, S34, S36, S37, S40, S41, S42, S45, S48, S49, S54, S55, S56, S57, S59, S59	38
<b>Totals</b>	<b>60</b>	<b>60</b>

**Key:**

**S1, S2 – subject 1, subject 2**

Table 8 shows clearly that 3 writers (5% of the students) did not go beyond level 0 of written expression even after their Undergraduate training in FLE whereas 5 (8% of the students) among them attained level 2. Nevertheless, 14 students attained level (1) and 38 level 3 representing 23% and 63% of the students of the study population, respectively.

**Conclusion**

At the end of this study on evaluation of textual competence related to narrative texts, the empirical findings obtained permit us to describe the characteristics of these writings and through them, the level attained by the writers. These findings are the result of a global approach in text analysis that evaluates textual competence through its components. These components contain some indicators that qualify cohesion in the narrative texts: we can mention the initial and final stages of a story, the connectors of time expressing the story progress, the

commonly used tense in narration and the richness in vocabulary. In order to evaluate the acquisition of such indicators, we resort to the *ad hoc* grid that comprises 75% of core criteria and 25% of criteria of perfection. In regard to the different types of competence which serve as a barometer to textual competence, this study indicates that the subjects have a good mastery of general competence in writing; thus the majority among them are able to produce texts that are legible, punctuated and have accents placed on words in a satisfactory manner.

Furthermore, although the writers have a good mastery of pragmatic and communication competence, their texts show lack or dysfunction of connectors of time. Because of this dysfunction, the writers have difficulty in coordinating sentences in their writing. Whereas they are capable of narrating events in line with the given topic, they do not express them in a discourse that flows. On the other hand, even though their

stories tell the actions that take place in a given time and space, the lack of knowledge on the functions of connectors of time is a handicap to textual progression and cohesion. Kilosho (2011) also made this observation on the students of Kenyatta University, whom due to lack of logical articulation, do not make ideas flow but jump from one subject to another, which weakens textual coherence.

We also observe that the investigated writers have an average mastery of linguistic competence of vocabulary. In this regard, the study shows that the lexical coverage of the proposed themes remain below average because the vocabulary used remains poor and is not varied although its use appears to be generally appropriate. More over, the recurrent orthographic errors concern all domains of graphical errors: morphogrammic, phonogrammic and lexicogrammic.

Except for errors in grammatical agreements as well as in the endings of verbs, the study shows that linguistic competence in morphology is globally mastered. Nevertheless, global mastery of syntax competence does not concern the complex sentence; since the latter is not subjected, in most cases, to the rule of the sequence of tenses. Due to lack of present and simple past tense, the corpus study only used the past tenses like *imparfait* and *passé composé*, without paying attention to the requirement of tense sequences.

Finally we observe a rising curved line on the level of written expression which shows that the more the level grows, the higher the numbers of candidates. It follows that the majority of students, 86%, achieved or even surpassed the threshold level in training in written expression; but only 63% of them globally have a good linguistic and textual mastery. These results should not overshadow the paltry performance of 14% of the candidates who have not mastered the very basic knowledge during their training in

FLE or have no mastery of the basic elements in writing.

## Références

- Adam, M.** (2008), *les textes: types et prototypes*, Armand Colin, Paris.
- Chokah, M.** (2003), "La formation des enseignants de FLE au Kenya : le cas particulier de l'Université Kenyatta", thèse de doctorat, sous la direction du Prof. Marc Souchon/Université de Franche-Comté, Besançon.
- Degand, L. et Hadermann, P.** (2008). *La langue en contexte*, in Actes du colloque « Représentation du sens linguistique IV) tenu du 28 au 30 Mai 2008, Helsinki.
- Dabene, M.** (1990) : *Des écrits (extra)ordinaires, éléments pour une analyse de l'activité scripturale*, LIDIL n°3. Presses Universitaires de Grenoble.
- Fayol, M.** (1991) : *La production d'écrits et la psychologie cognitive*, in Le Français aujourd'hui, n° 93, Paris.
- Gabillet, P. et Montbron, Y.** (1998). *Se former soi-même, les outils de l'autoformation*, ESF, Paris.
- Grice, H.** (1979). *Further notes on logic and conversation*, in Cole edition, London.
- Jolibert, B. et Gloton, R.** (1975). *Le pouvoir de lire*, Casterman, Paris.
- Holtzer, G.** (2002), *l'évaluation de quelques procédés de textualisation chez des élèves guinéens en fin de cycle primaire*, in Recherches sur le français en Guinée/Annales de l'université de Franche-Comté, Besançon, Presse Universitaire Franc-comtoise.
- KNEC.** (2005, 2006, 2007, 2008). *The Kenya National Examinations Council Year KCSE Examination Reports*, KNEC, Nairobi.
- Kilosho, K.** (2011). *Pour une pédagogie de l'erreur dans nos universités*, in revue Analyses No 14 /Mars 2011, Toulouse.
- Ogutu, J.** (2010). *Espace géoculturel, écriture, texture et l'enseignement du français écrit en contexte kenyan*, Thèse de doctorat, sous la direction de Cotin Martine/Université de Franche-Comté, Besançon.

**Rück, H.** (1991). *Linguistique textuelle*, Didier, Paris. **Tagliante, C.** (2005). *L'évaluation et le cadre européen commun*, Nathan, Paris.

# ***Chamas* as Informal Social Protection among Street Vendors and Market Sellers in Kisumu City, Kenya: Perceptions of Poverty, Vulnerability and Exclusion**

By

**Karen N. Nyangara<sup>1\*</sup>**

*1; Department of Education, Communication and Technology, Maseno University*

*\*Corresponding author: [karennyangara@maseno.ac.ke](mailto:karennyangara@maseno.ac.ke)*

---

## **Abstract**

Formal social protection programs in Kenya were initiated to assist the vulnerable access medication, financial assistance, education and old age pensions. However, conditions for eligibility lock out the poor who have low or fluctuating monetary incomes such as street vendors and market sellers in Kisumu city. *Chamas* serve instead as a form of informal social protection, but little is documented about the extent to which members benefit from this protection. This study assessed perceptions of poverty, vulnerability and exclusion among Kisumu City street vendors and market sellers. Snowballing and stratified sampling was used to attain a sample of seven *Chamas* with a total of 536 members. Data was collected using an interview guide, questionnaires, and focus group interviews. Data was analyzed both qualitatively and quantitatively. While most market vendors and street sellers are members of a *Chamas*, the groups have minimal impact on social protection because of their low income base.

**Key words:** Social protection, *Chamas*, poverty and vulnerability, exclusion, potentiality, challenges.

---

## **Background**

Kisumu City is the 3<sup>rd</sup> largest town in Kenya with an estimated population of about 600,000.

Approximately 61% classified as poor in Kisumu City, with 48% of the urban population living below the poverty line, as compared to a national average of 29%. Unemployment is estimated at 30% with majority of economic activity taking place in the informal sector (Republic of Kenya, 2008; 2009). The high poverty rate is compounded by the highest national levels of prevalence of HIV at 15.1% against a national average of 6.4% and a high fertility

rate of 4.9 against the county rate of 3.98 (Central Intelligence Agency, 2011).

Norton, Conway and Foster (2001) define social protection as public actions taken in response to levels of vulnerability, risk and deprivation which are deemed socially unacceptable within a given polity or society. The Kenya National Social Protection Policy of 2011 describes this protection as:

*Policies and actions, including legislative measures, that enhance the capacity of and opportunities for the poor and vulnerable to improve and sustain their lives, livelihoods, and welfare, that enable income-earners and their dependants to*



*maintain a reasonable level of income through decent work, and that ensure access to affordable healthcare, social security, and social assistance.*

Why the need for social protection? Social protection is meant to cushion poor against disasters that can lead to impoverishment. It can assist people in escaping from chronic poverty, and reduces poverty, child labor and inequality. In the traditional African society children and the aged were taken care of by the extended family. However, urbanization has weakened the extended family system; with the money economy makes it increasingly expensive to bear the costs of caring for orphaned children, the sick and the aged.

In Kenya the National Social Security Fund (NSSF) was established in 1965 by an Act of Parliament (CAP 258 of the Laws of Kenya) in order to administer a provident fund scheme for all workers in Kenya. Initially the fund operated as a government department, and catered for those in formal employment. In 2013 the National Social Security Fund Bill was repealed and was replaced by the National Social Security Fund (NSSF, 2013) Act. Formal social protection also includes National Hospital Insurance Fund, free maternity and free treatment for under 5's, cash transfer programs for orphans and vulnerable children (OVC), older persons and persons with disability. The *Kazi Kwa Vijana initiative* for unemployed youth and the Hunger Safety Net Program (HSNP) for the chronically food insecure in the arid lands are also crucial programs for formal social protection.

Formal social protection as currently offered has several shortcomings. The contributions are specifically structured towards pensions and medical schemes, ignoring other causes of vulnerability. For example while the contributions to the NHIF assist with in-patient bed costs; they do not cover related costs such as purchase of medicines. The contributions to NSSF are also so low that they cannot guarantee an adequate income

in old age. Schemes targeting youth employment, old age relief and food safety often rely heavily on donor funding, and therefore may not be sustainable. Chen (2007) asserts that the self employed are often invisible in national statistics that fail to adequately capture the range and types of activities that people do in the informal sector.

The new social protection policy seeks to change the scope and coverage of the (NSSF) to include small and micro entrepreneurs and casual workers. However, the eligibility requirements still leave out a huge segment of the population, hence the need for informal social protection. These requirements do not take into consideration that segment of workers and entrepreneurs with fluctuating incomes.

Vulnerability is a combination of characteristics of an individual or a group expressed in relation to exposure to hazards because of the individual or group's socio-economic condition. Vulnerability is also determined by physical, natural, financial, social and human assets within the community that can be accessed by the poor. Class, community structure, ethnicity and political issues compound vulnerability. Vulnerability measures the extent to which a shock will result in a decline in wellbeing (Deininger and Liu, 2009). Shocks include loss of income, illness and natural disasters such as floods or fires. Shocks may be sudden, cyclical, repeated or long term.

Exclusion refers to the inability of the state/government to provide support to the vulnerable in times of hardship and need. Exclusion can be economic, social and political (Fafchamps and La Ferrara, 2010). When exclusion is economic, it leads to most other forms of exclusion. Since the poor cannot afford to pay for social protection they are ignored as stakeholders in social and political spheres. The poor are likely to be by-passed by the opportunities that economic growth offers since they do not possess the

needed resources to prosper (De Coninck and Drani, 2009).

Informal social protection is one of the ways in which those who cannot fit into the formal social protection schemes. Devereux and Sabates-Wheeler (2004) conceptualize four dimensions that enable a program or system to qualify as social protection. It must contain preventive measures to help manage shocks; it must protect those unable to work, or the vulnerable such as orphans; it must promote the generation of income, and it must address social inequalities that lead to exclusion. Based on this conceptualization, it may be argued that the informal group is then able to improve the life of its members, although this paper further argues that this transformation cannot occur in isolation, and needs to be studied in the context of the perceptions of members in relation to informal social protection.

A *Chama* (Kiswahili for group or committee) typically consists of members who share a common attribute such as friendship, business or employment. *Chamas* are built on two principles. The first principle is that the pooled individual savings of members is the foundation for building capital, with the motivation to save coming from the groups (Wild *et al.*, 2008). Savings groups, commonly known as “merry-go-rounds”, collect a set amount from each member. The whole group’s contribution is given to one or more members each month in turn for the purchase of household items or goods for trade. Depending on the income of the members, some of these groups grow into investment clubs where part of the money saved is invested and used to purchase assets for the group.

The second principle is the basis of protection being mutual networks of support and shared aims (Fafchamps and La Ferrara, 2010). All *Chamas* have a constitution and rules and regulations that govern who can join, under what circumstances members can benefit and also termination of membership. Some groups purchase goods for sale on a

wholesale basis and therefore support each other in building the business.

*Chamas* incorporate social protection aspects that include lifestyle needs such as weddings, funerals, childbirth and education; personal emergencies such as sickness, injury, theft and death; disasters such as destruction of homes or business premises; fires or floods; and investment opportunities such as expanding a business, buying assets or building a house (Rutherford, 2004). Despite the measures taken by the groups, there are several challenges to eventually becoming part of the mainstream formal protection schemes. Do members understand why they are not in formal social protection? How do they perceive their social status in relation to these schemes? What are their perceptions of their exclusion, poverty and vulnerability in relation to their need for social protection?

### **Perceptions of Poverty, Vulnerability and Exclusion**

The study sampled 536 members in 7 *Chamas* from street vendors and market sellers in Kisumu City. The main market areas were Oile Market and Kibuye Market. Oile market has two trading areas: the main county market that is in an enclosed space, and the open air market with traders selling their wares in stalls or laid out on the ground, each trader having a space of about 6 feet square. Kibuye market is one of the largest open air markets in Africa, with traders selling goods ranging from second hand clothes, fresh produce and furniture to hardware goods and building materials. Vendors were drawn from the main streets in Kisumu Central Business District. These traders include newspaper vendors, hawkers and repairmen. Although the gender representation was almost equal with 53.73% male 46.27% female, the economic activities of respondents are clearly demarcated by gender.

Data collection instruments consisted of a survey questionnaire for group members, focus group discussion (FGD) guide and an interview schedule for group leaders.

### **Q1. Who is a poor person?**

The Poverty Reduction Strategy Paper for the Period 2001-2004 (Republic of Kenya, 2000) defines poverty as the inability to feed self and family, lack of proper housing, poor health and inability to educate children and pay medical bills. According to this definition, 15 million Kenyans were poor in 1997 and currently an estimated 56% of the Kenyan population now lives below the poverty line. The government adopted poverty lines of Ksh 2,648 (US\$ 33.1) in urban areas and Ksh 1,238 (US\$ 15.5) in rural areas per adult per month. The figures, however, are indicative of income but do not take into account expenditure. The average income of the street vendors and market sellers was an average of Kshs 1530 (US\$ 19.2) per month, after deduction of all business related expenses, placing them among the urban poor.

However, when asked to state who a poor person is the respondents stated that:

The one who does not have anything to do”

“A sick (disabled) person who is blind”

“A person without respect”

From the comments it is clear that the respondents in the study do not consider themselves poor, although their income range ranks them in that category. Asked to elaborate what kind of income generating projects the poor engage in they mentioned selling of kerosene (paraffin), making ropes, fishing, cobblers and charcoal sellers. These are smaller scale businesses carried out in the slum areas, and present an interesting scenario for further study.

### **Q2. Are you a Vulnerable Person?**

The concept of vulnerability was examined from both an individual and a group perspective.

70.55% of the respondents felt that they are individually vulnerable due to several reasons. All respondents felt vulnerable due to their income levels, 71% due to their family position and 43% due to their gender. No respondent thought that disability, health, age, marital status, political

alignment and cultural beliefs and values cause their vulnerability and/or exclusion. Family position carries with it the weight of responsibility, since many look after siblings, aged parents or the children of their siblings.

The respondents identified inadequate funds (100%) and lack of technical capacity (85.7%) as the main reasons why the groups are vulnerable. In addition they cited erratic contributions as contributing to vulnerability because it meant there were not always enough funds to cushion deserving members in times of need.

### **Q3. Are you Excluded?**

Exclusion was explored in terms of receipt of services which are meant to protect the poor from risks. These include: insurance against business and personal loss, health risks and protection from arbitrary or ill-conceived decisions by the city officials. The respondents identified several risks. Risks result in reduction in stock (85.5%), inability to pay an existing *Chama* loan (86.6%) and selling of assets, including business assets (71.6%).

None of the respondents belong to the NSSF, while only 28% were registered with the NHIF.

The reasons given for not registering were the high monthly fees, and the limitation of the services offered. Currently the registration fee (self employed persons/voluntary) for NSSF is Kshs 200, Kshs 160 for NHIF per month. 73% of the respondents stated that in months with good business they would be able to raise the fees, but they did not join these schemes because they would end up defaulting when business was poor.

All seven *Chamas* run bank accounts in microfinance institutions and in commercial banks that have low account maintenance fees. These banks include *Adok Timo*, K-Rep, Equity and Family Banks and the Kenya Agency for Development of Enterprise and Technology (KADET). On an individual basis, only 22% bank their money. The main

reason given by 97% of the respondents was that they had nothing left over to bank after meeting all their other expenses. None of the members pay insurance on their businesses, or to guard against personal risks.

### Conclusion

Informal social protection strategies are a core aspect of the lives of street vendors and market women in Kisumu City, Kenya. While the respondents perceive themselves as vulnerable and excluded from formal social protection, they do not perceive themselves as poor. *Chamas* are not established for economic need alone, but as a fall-back measure when shocks affect the ability of members to cope. The major challenge that confronts the efforts of the *Chama* to offer adequate social protection to its members is the lack of adequate funds.

The current framework for formal social protection needs to focus on those who are vulnerable and are excluded, not because of extreme poverty, disability or gender, but because they do not have enough of an income to benefit.

### References

- Central Intelligence Agency.** (2011). *The World Factbook*. Available online at [www.cia.gov](http://www.cia.gov).
- De Coninck, J. and Drani, E.** (2009). *Culture and social protection for the very poor in Uganda: Evidence and policy implications*

Working Paper No. 140. Chronic Poverty Research Centre.

[www.chronicpoverty.org](http://www.chronicpoverty.org) (accessed March 12, 2013).

- Deininger, K. and Liu, Y.** (2009). *Longer-term economic impacts of self-help groups in India*. The World Bank Group, Policy Research Working Paper 4886.
- Fafchamps, M. and La Ferraraz, E.** (2010). *Self-Help Groups and Mutual Assistance: Evidence from Urban Kenya*. University of Oxford/ESRC Global Poverty Resources Group.
- Norton, A., Conway, T. and Foster, M.** (2001). *Social protection concepts and approaches: Implications for policy and practice in international development*, working Paper 143. London: Overseas Development Institute.
- Republic of Kenya.** (2000). *The Poverty Reduction Strategy Paper, 2001-2004*. Nairobi: Government Printer.
- Republic of Kenya.** (2008). *National Social Protection Strategy*. Nairobi: Government Printer.
- Republic of Kenya.** (2012). *Kenya Aids Indicator Survey, 2012*. Nairobi: National Aids and STI Control Programme.
- Republic of Kenya.** (2009). *Kisumu District Development Plan, 2008-2012*. Nairobi: Government Printer.
- Rutherford, S.** (2000). *The Poor and Their Money*. Delhi: Oxford University Press.

# **Analysis of the Disaster Management Policy and the Challenges Faced by the County Government Authorities in Disaster Awareness and Management in Kenya**

By

**Jasper E. Nyaura<sup>1\*</sup> and Margaret N. Ngugi<sup>1</sup>**

<sup>1</sup>*Department of Peace, Security and Social Studies, Faculty of Arts and Social Sciences Egerton University, P.O.Box 536 -20115 , Egerton-Njoro, Kenya*

*\*Corresponding author: [edward.nyaura@yahoo.com](mailto:edward.nyaura@yahoo.com)*

---

## **Abstract**

In the recent years, disaster has affected the Kenyan citizenry from every part of the country. Moreover, disasters have led to loss of life with the majority of the vulnerable groups in Kenya suffering the most. The introduction of the new county governance has seen a shift in the transformation of the municipal assets to county assets. However, the county governments still lack the capacity in terms of education and training in disaster management. This paper addressed the legislative and mitigation efforts by the national and the county government through the analysis of the Disaster Management Policy (2010) among other policies. Furthermore, the paper focused on the efforts by the non-governmental agencies, the set-up structures in the Disaster Management Policy (2010) entailing disaster preparedness and disaster prevention mechanisms at the county government level. The paper provided analysis of probable challenges facing the county government authorities and community members in alleviating disasters. The recommendations put forward include that there is need for mitigation and prevention strategies that have to be put in place to prevent further disasters from taking place. Policies need not only be in paper but also be put into practices with the existing structures, facilities and staffing in the county governments.

**Key Words:** Disaster Management Policy, County Authority, Disaster, Management, Challenges.

---

## **Introduction**

In each and every part of the world disaster affects every citizenry and most of all it affects those who are vulnerable. According to the National Disaster draft policy (2012), the disaster risks in Kenya take in the form of natural hazards such as floods and drought or human induced such as civil strife, acts of terrorism, industrial and transport accidents among others. Moreover,

Kenya faces the epidemics threats emerging and re-emerging from diseases such as spread of HIV/AIDS, H1N1 virus, Ebola and Malaria. The recent West Gate disaster caused by terrorism is seen as the Kenya's unprepared state where lack of coordination by various government agencies was seen as the main impediment to safeguarding and containing the disaster. Furthermore the Kiambu fire reported by the K-24 television

station is seen as another disaster that resulted in the destruction of property worth millions yet the fire fighters were present.

Accordingly, Suda (2000) has indicated that environmental degradation has resulted to natural disasters like droughts, floods and landslides that have contributed to massive environmental implications to both the urban and rural areas of Kenya. Moreover, communities are prone to disasters due to a combination of factors such as poverty, drought, settlement in areas having recurrent flooding or areas with poor infrastructure and services such as the informal urban settlements or even living in poorly constructed buildings thus these hazards have increased in number, frequency and complexity (Nabutola, 2012).

Terrorism has been seen as the current disaster that faces the Kenyan government today. The frequent threats by the Al Shabaab and its affiliates in the coastal in Kenya have resulted to reduced tourism growth. Moreover, the lack of unpreparedness by the various county governments in Kenya is a clear indication of the concern by its citizens by asking questions such as are we prepared for another attack? Are we ready for the drought since there is no rain? And finally do we have faith in the county government to ensure that the citizenry are safe from any kind of disaster? Thus this paper will address the legislative mitigation efforts by the national and the county government, efforts by the non-governmental agencies, the set-up structures entailing disaster preparedness and disaster prevention mechanisms and finally the challenges facing the county government authorities in alleviating disasters.

### **Disaster Risk Reduction Strategies**

According to the Disaster Management Policy (2010) points out that disaster risk reduction is a systematic approach aimed at minimizing vulnerabilities and disaster risks throughout a society, to avoid or to limit the adverse impacts of hazards, within the broad context of sustainable development. The

disaster risk reduction framework is composed of the following fields of action: Risk awareness and assessment including hazard analysis and vulnerability/capacity analysis; Knowledge development including education, training, research and information; Public commitment and institutional frameworks, including organizational, policy, legislation and community action; Early warning systems including forecasting, dissemination of warnings preparedness measures and response capacities; Application of measures including environmental management, land-use and urban planning, protection of critical facilities, application of science and technology, partnership and networking, and financial instruments.

### **History of Disasters in Kenya**

Kenya has experienced more disasters that include; (organized chronologically according to years) the 1984 to present: HIV/AIDS pandemic that later led to the spreading of HIV/AIDS through infecting and affecting community members; the 1991/92/93 drought affected about 1.5 million people in the Northern region of Kenya; the 1994 Mtongwe ferry accident in Mombasa that saw 270 people died; the Elnino floods of the 1997/98 which affected 1.5 million people especially those in the Budalangi Region Western part of Kenya; the United States Embassy in bomb blast attack by the Al-Qaida in Nairobi where 214 people died and 5,600 injured; the 2002 Kikambala bomb attack (Paradise Hotel in Mombasa) which saw 13 people dead; the 2003, 2004, 2005 severe drought that affected the country; the recent 2007/2008 Post election violence in which 1,300 people were killed and 660,000 displaced; the 2009 Sachang'wan fire disaster which killed many People; the 2009/2010 Cases of floods and landslides were reported and the recent West Gate terrorism (2013) that saw nearly 70 people died.

## **Mitigation Efforts through Legislation and Government Policy Formulation Efforts**

The mitigation efforts by the government have been chronologically organized as followed:

### ***National Disaster Relief Regulations (NDRR) - 1982***

The government of Kenya established the 1982 act of parliament that was under the Ministry of Home Affairs. It further established the Natural Disaster Relief Committees, which further had sub committees that include: Relief and Treatment Sub-Committee, Supply, Shelter and Rehabilitation Sub-Committee, Regional Natural Disaster Relief Committees and Local. However the committees remained dormant.

**Drawbacks:** of the National Disaster Relief Regulations (NDRR) of 1982 act of this act of parliament entail the fact that there are no clear functions and duties of all district disaster management related agencies, moreover the problem of cooperation, coordination and mutual understanding between various district management related agencies. Furthermore, some of the district management related agencies have shifted their responsibilities to the others thus is no clear-cut job description in the Act. Consequently, disaster victims do not get immediate, efficient and effective rescue and relief services. Delayed relief works often brings very serious and unpleasant results. Accordingly, duplication of relief works has also been experienced, mainly due to the absence of dialogue and mutual understanding among disaster management related agencies (Nabutola, 2012).

### ***Relief and Rehabilitation Unit and Arid Land Resource Management Projects***

The Relief and Rehabilitation unit and an Emergency Drought Recovery Project were established in 1993 to address the consequences of frequent droughts in arid area in the country. However, the Drought Recovery Project was phased out in 1996

and in its place Arid Lands Resource Management Project I which was put in place to carry out drought monitoring and management activities in 10 arid districts in Northern Kenya. The Project (ALRMP II) was expanded in the year 2003 to cover 22 Arid and Semi-Arid districts. Another 6 districts have since been added to this project (Nabutola, 2012).

### ***Establishment of National Disaster Operation Centre***

National Disaster Operations Centre established by the Kenyan Government in the early 1998 was at the height of El-Nino induced floods in Tana River and Budalangi Region of Western part of Kenya. Its purpose was to monitor the floods and providing logistical support in assisting the communities in the flood areas. The government has retained the center to monitor disaster incidents on a 24-hour basis and to mobilize responses to the areas affected disaster. Moreover, other stakeholders have also pursued a wide range of strategies and programme to respond to disasters in the country (Nabutola, 2012). Further these initiatives have been undertaken in a relatively more reactive and poorly coordinated manner without a coherent policy framework.

**Drawbacks:** of the establishment of the NDOC was the fact that the center was faced by shortage and lack of consultation with various key actors in the field of disaster management. The Kenyan Government has addressed these drawbacks by establishing draft policy has been prepared to address. Moreover, the formulation has taken account the considerations and the lessons learnt during the management of various disasters in the past.

### ***Disaster Management Policy- Policy Drafting after Attack on the US Embassy- 1999***

Soon after attack on the US Embassy in Nairobi by the Al-Qaida the Kenyan government drafted a policy in the early 1999. Furthermore, the assistance from multiple international and civil society

organizations, the Government of Kenya has facilitated numerous sessions to gather stakeholder input and advice on the drafting of the policy for implementation. In 2007 the draft policy was presented to the Cabinet sub-committee on the humanitarian affairs. In the early 2009, a revised draft policy through stakeholder input which incorporated on earlier drafts and more recent findings from the international and other national best practices for disaster management policies and structures. The establishment of the task force drawn from the Kenya National Disaster Risk Reduction platform further enriched and fully aligned the disaster policy to the new constitutional dispensation, which was promulgated on 27th August 2010 by the Government. The Disaster Management Policy document was developed by the Ministry of State for Special Programmes (MOSSP) with technical and financial support from World Vision, Kenya and UNDP (Kenya).

Through the adoption of this policy, the Government of Kenya has committed itself to undertake the key changes that include:

- a) Establishing an institutional and legal framework that streamlines processes for effective and efficient disaster management in the country. This includes the establishment of national disaster management directorates under the MRDM and promoting the National Platform for Disaster Risk Reduction to be the overarching humanitarian coordination forum for Kenya to integrate qualified actors and initiatives.
- b) Recognition of the severe risks Climate Change poses for Kenya and its likelihood of exacerbating existing hazards and making disasters less predictable. The importance of devising measures to help the people of Kenya adjust through climate change adaptation efforts, including disaster risk reduction, is a foundational concept throughout this policy.
- c) Incorporating and adjusting the conceptual thinking behind disaster management in Kenya to fully embrace

the paradigm shift which has taken place over the past decade from thinking about a disaster response-centric approach to a balanced and proactive Disaster Risk Management approach. Prevention, preparedness and recovery are therefore fully embraced and the view of hazards broadened to include violence, disease and conflict among others.

- d) Promoting an increased national disaster awareness culture and capacity building for disaster preparedness at all levels.
- e) Ensuring that all role players in disaster risk management are well coordinated and focused by fostering collaborative partnerships with the Government at all levels, civil society organizations, the private sector and regional and international organizations.
- f) Promoting linkages between disaster risk management and development processes for reduction of vulnerability to hazards.
- g) Establishing a Disaster Relief Trust Fund for disaster risk management and risk reduction programmes.

Other legislations on disaster management include;

- a) Natural Disaster relief Act, 1982 and the Local Government Act (LGA) Chapter 265, in the Laws of Kenya have provisions that give local authorities the mandate to provide disaster mitigation, although they do not mention disaster management in the main Act. Sections 154 (d), 60c, 160K, 179, 166 give provisions for disaster management.
- b) Environment Management Act of 1999,
- c) Kenya Red Cross Society Act (Cap 256),
- d) Water Act (Cap 372)

#### ***Mitigation Efforts by the Other Government Agencies and Non-governmental Organizations***

Specialized organizations and departments which have roles in search and rescue, relief, anti-terrorism, evacuation, safety and public order, disaster planning and management, enforcement of crowd control, conflict resolution and fire fighting. These include;



Kenya Police (Including the GSU); Ministry responsible for State for Defense; National Youth Services; Local Authorities' Fire Brigade; St. John's Ambulance Service, KRCS; Directorate of Occupational Safety and Health Services; Kenya Wildlife Service and finally the National Environment Management Agency.

Accordingly, the GoK (2010) the institutions deal with disaster management are mostly uncoordinated, reactive and haphazard resulting to duplication of efforts, wastage of scarce resources and enormous disaster losses. Moreover, the involvements of the Red-Cross Kenya among other non-governmental organizations have filled the gaps where the government has not been able to perform. This is seen with recent attacks including the Water Gate terrorist attack where the Kenya Red cross was first to report on the scene thus their response towards disaster management is high.

Accordingly, the GoK of the Disaster Management Policy (2010) indicates that in exceptional circumstances the Armed Forces should support and coordinate disaster operations. The technical skills and logistics capacity of the Armed Forces may be a critical element in delivering a well-coordinated and effective response, however it has to be carefully coordinated and managed. However, there is no protocol in place to prepare for and define such roles. The policy further appropriates the inclusion and adoption of international agency policies including the UN protocols, guidelines and training through the Civil Military Coordination (CIMCORD) initiative for clear use and integration of the Armed Forces into the national disaster management coordination system. The nation's Armed Forces would also play an important role in leading the coordination of supporting foreign armed forces arriving to provide humanitarian help in a major disaster. An example, that is acknowledged in Disaster Management Policy is the Joint Services Coordination demonstrated during the Indian Ocean Tsunami in 2005 and in

Indian and Pakistan during the earthquake in the same year.

### **Structures under County Government with regard to Disaster Management Policy (2010)**

The Disaster Management Policy (2010) strengthens the county government's capability for effective and efficient disaster management. The policy further acknowledges that counties do not have coordination mechanism and Disaster Risk Reduction (DRR) framework to guide their initiatives. This requires the joint consultation between the county government and the Ministry responsible for disaster Management that shall develop an effective DRR coordination mechanism and framework. Coordination between various government organs at the county will be strengthened, capacity enhanced and other stakeholders incorporated.

### ***Role of the County Governments in Disaster Risk Management***

Accordingly, the GoK Disaster Management Policy (2010) provides that County governments, through Governors will entail the following functions through Disaster Risk Reduction: Ensure that DRR is a county priority with a strong institutional and coordination mechanism. All county policies, plans and initiatives should integrate DRR issues; Develop or strengthen disaster preparedness mechanism for effective response at community level including but not limited to establishing strategic stockpiles, contingency Planning, search and rescue, First Aid, disaster recovery planning among others; Develop disaster information data base, communication and dissemination strategy on county disaster risks and enhance early warning; Ensure DRM is integrated into critical sectors including but not limited to health, construction, infrastructure, agriculture, environment and natural resources, county economic plans and physical planning. Mainstream climate change related risks; and finally to establish county disaster dissemination and education

strategy including factoring DRR issues into county education system and community awareness strategy.

### ***County Disaster Management Committees (CDMC)***

The policy requirement entail the fact that various counties are required to establish a Disaster Management Committee (CDMC) to coordinate and supervise disaster management activities that spread across one or more sub counties within a county or exceed the capacities of a sub county but can still be managed by county resources.

The policy further points out that CDMC will be chaired by the County Governor and supported by county staff and partner organizations. The functions of committee as stipulated in the Disaster Management Policy include:

- a) Coordinating emergency response in the county in liaison with Ministry responsible for disaster Management.
- b) Operating the county/sub-county communication and early warning system.
- c) Coordinating compilation of County/sub county disaster contingency plans.
- d) Administering and accounting for disaster funds.
- e) Appointing lead and partner agencies through memoranda of understanding, to be responsible for coordinating emergency responses in their areas of jurisdiction.
- f) Conducting inventory on the response capacity of the emergency services and disaster experts including volunteers.
- g) Working with other committees to support community in disaster management.
- h) Organizing and participating in disaster management education and training needs assessment in conjunction with local experts, volunteers and trained personnel.
- i) Monitoring and evaluating disaster management activities in the provinces.
- j) Coordinating training and public awareness activities.

- k) Coordinating DRR activities and main streaming them in development plans.

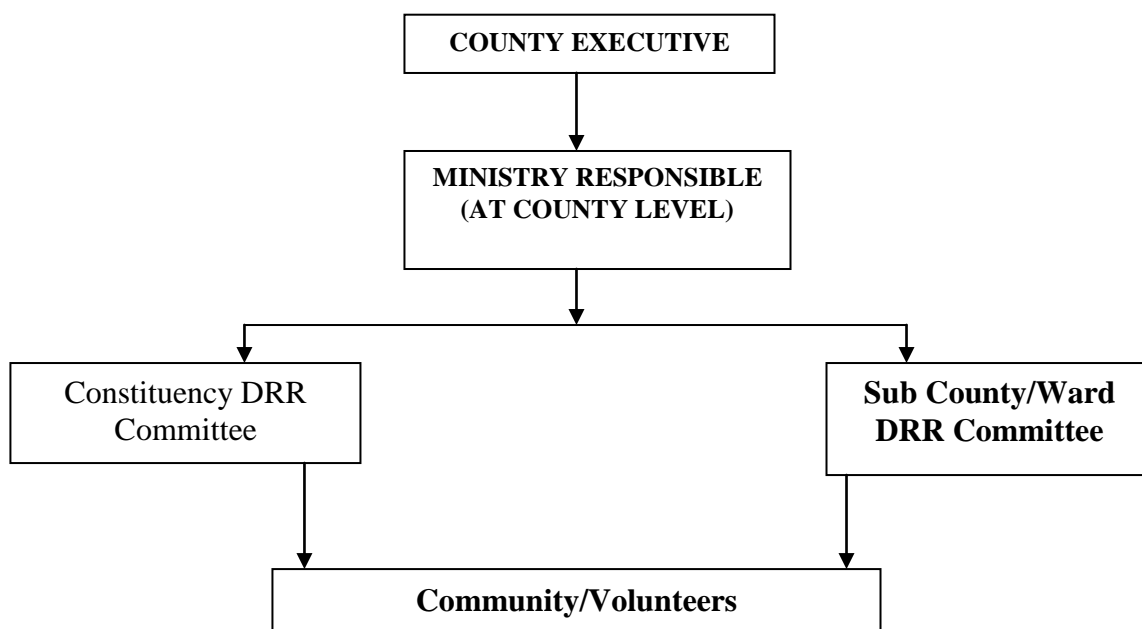
In circumstances where non-governmental partners maintain greater capacity than the government in a given county, the chair of the committee may delegate incident command, preparedness planning and recovery responsibilities to such organizations. The Committees will bring together resources and expertise from relevant departments, CSOs, the private sector, development partners, qualified volunteers from partner organizations and other stakeholders operating in the county.

Accordingly the disaster management policy (2010) identifies structures that include the DM/DRR County Coordinators responsibilities: Promote DRR by sensitizing the public to risks, providing preparedness advice and disseminating early warning information; Support state and non state actors at the county to establish DRR sectoral plans and Programmes; Coordinate research and data collection regarding their regional/county disaster risks; Facilitate training for National, County and community organizations and volunteers; Liaise between the Directorate of Response; Relief and Recovery; County and Community leaders during a disaster and assume incident command responsibilities when necessary; County Disaster Response Units and the eventual establishment Sub county disaster risk reduction coordination mechanisms.

Furthermore the policy provided for the establishment of the Sub County Disaster Management Committees (SCDMC) that will be chaired by the Sub County Authority and supported by Sub county staff and community partners. In circumstances where non-governmental partners maintain greater capacity than the government in a given Sub county chair of the committee may delegate incident command, preparedness planning and recovery responsibilities to such organizations. The responsibilities include: Coordinating emergency disaster

preparedness and response in the sub counties under the guidance of the SCDMC and MRDM; Establish and operate the county/sub county early warning system; Coordinating compilation of sub county disaster contingency plans including transport and logistics; Resource mobilization and administering disaster funds; Conducting inventory on the response capacity of the emergency services providers and disaster experts including qualified volunteers; Organizing and participating in DM education and training needs

assessment in conjunction with local experts, qualified volunteers and trained personnel; Monitoring and evaluating DM activities in the counties and sub counties; Coordinating disaster reduction training and public awareness activities; Coordinating DRR activities and main streaming them in development plans and finally Support mobilization of resources for disaster management functions. Figure 1 shows the diagrammatic elaboration of the structure of county government.



**Figure 1:** Structure of County Government DRR coordination mechanism.

***National Funding Mechanisms for Disaster Management in Kenya***

Accordingly, funding is essential for the prevention and enabling disaster awareness and reduction thus the policy has indicated the following funding mechanisms from both the National government and county governments:

***A. Disaster Relief Trust Fund***

The Government of Kenya funds relief food. The NDMP proposes the establishment of a Disaster Relief Trust Fund with contributions from the exchequer, private sector, individuals, CSOs, development partners and stakeholders. Management of the fund has been by a Board of Trustees and

will address all phases of disaster management, prevention, mitigation, response, recovery, rehabilitation and reconstruction.

***B. Directorates Budget***

The Government of Kenya through the MRDM will provide a core budget for the national DM/DRR directorates. This core budget is expected to be significantly augmented through contributions of staff, stocks, programme and relief contributions from partner organizations and external donors.

### ***C. Devolved funds***

Devolved funds such as LATF, CDF and all other funds to county government shall allocate no less than 5% of their allocation of disaster management activities. Specific allocation for each county budget should be earmarked annually for Disaster Management.

### **Challenges facing the Local Authority (County Governments) and Community Members in alleviating disasters in relation to Disaster Management Policy**

#### **Challenges Facing Local Authority in Alleviating Disasters**

##### ***Lack of a Standard Operational Procedures and Resource Prioritization***

According to the Draft Policy for Disaster Management (2009) disaster response activities are poorly coordinated, due to lack of standard operational procedures and Disaster Emergency Operation Plans. This situation remains a challenge that has led to duplication of efforts and wasteful use of resources. This in turn this exposes disaster victims to greater risks and slow recovery. The county governments have not yet set up operational plans that will directly prevent disasters from prevailing. Due to lack of prioritization, resources have been channeled elsewhere thus when disaster strikes there is no room for saving lives and at the same time reducing the risks. Furthermore, the counties in existence still lack the capacity to curb disaster by lacking resources. Moreover, when there is inferno in various buildings and areas of residence, the community members result to crude methods of putting out fire. This sometimes results to some members getting injured in the process.

##### ***Inadequate Training Education towards Disaster Preparedness and Prevention***

Accordingly, County Disaster Management Committees have failed to organize disaster management education and training needs assessment with local experts, volunteers and trained personnel. The Red Cross among

other non-governmental organizations has filled this gap. Fire is seen as the main disaster that affects major urban centers, the recent Sinai fire witnessed the deaths of the inhabitants of Sinai and the former city council was seen not to have done anything about the prevailing disaster.

##### ***Poor Infrastructural Capacity is another factor***

The ability to construct and maintain infrastructure makes it proper for disaster preparedness and management. However, in the forty Seven (47) counties there are no designated lanes for firefighters to maneuver their vehicles in cases of emergencies. At the same time, the government has been seen to be little interested to abide by the Disaster Management Policy. More so, in the case of the ambulances, there is still reluctance by the county governments to acknowledge their role in saving lives in cases of disasters. The Kenyan government in conjunction with the 47 counties should develop policies that concur with the USA and Britain among other developed countries disaster management policies because of their effective and efficiency to serve human diversity and at the same time serving its citizenry.

Furthermore, the various county governments have not put up infrastructure to help in curbing disasters, for example, the lack of established water access points to assist the fire fighters have been seen to be lacking thus there is need for established access of these water points. For instance the common phrase among the citizens is that: *the fire fighters came and the water they had was finished and due to lack of water the fire consumed the whole building*. More so, there has been no allocation of appropriate assembly points at the slum area in major cities.

##### ***Inadequacy in terms of Unpreparedness and Appropriate Planning***

Accordingly, adverse disaster risk patterns are worsened by poor planning and uncoordinated settlement. Increasingly, poor development is to blame for risk creation and further increasing the probability of future

disasters (ISDR, 2002). More so, the County governments have not fully established proper coordinated planning strategies to counter disasters. An instance is when disaster strikes *'that is when the talk is most'*. Furthermore, various county governments have not fully established systems to counter disaster, for instance, the establishment of disaster response centers that will create well-coordinated prevention strategies.

Moreover, studies have shown that officials responsible for disaster management at local government level are not knowledgeable of the IDP process, or of the elements that should be included in a comprehensive disaster management plan. Apparent confusion also reigns over the difference between disaster management plans and contingency plans (Van Niekerk, 2002 as cited in Vermaak and Van Niekerk, 2004).

#### **Inadequate Staffing and Material to curb disasters in the County Governments**

The ability to curb and at the same time fight disasters has been seen to be lacking. Accordingly, inadequate staffing and lack of material in curbing disasters has been seen to be the resultant effect of ineffective and inefficient is that when calamity strikes there is a lot of casualties. An example is when there are cases of fire there is delay in response because in every County there is one fire station or none at all. This is seen in the case of the Sinai fire. Another instance is when there are cases of floods in Budalangi area. The result of non-response is that there are casualties and deaths.

Moreover, the fire stations or emergency facilities do not have adequate facilities to address the need in fighting catastrophes. Furthermore, the government both at the national and county level have not adequately addressed the need for budgetary allocations in fighting disasters thus this has been seen to be lacking in preventing calamities. Most of the hospitals have no expansion for setting up emergency response units in cases of disaster. The county governments have neither facility nor the

staff in detecting disasters thus when there is disaster, they tend to rely on the non-governmental agencies such as the Kenya Red Cross.

#### **Challenges Facing the various Community Member in Alleviating Disasters**

##### ***Inadequate Proper Training on Basic life skills and awareness among community members***

Community members are essential in preventing and curbing disaster. Lacking basic life skills and training is one of the factors contributing to tragedies occurring. Furthermore, level of resilience is usually varied, people without diverse skills tend to be the most vulnerable groups in the face of natural calamities and environmental stress (Thompson, 1996 as cited in Suda, 2000). An instance is when there is a disaster has occurred, the community members in most cases lack basic first aid skills. The lack of basic knowledge on how to undertake an operation when there is a calamity, how to clear the vicinity where the disaster has occurred and more so they become the *'curious onlookers'* without assisting the injured has been seen a characteristic of every individual in Kenya. Furthermore, there has not been emphasize on the encouragement of first aid education, it is still considered as optional, yet it is crucial in the prevention of tragedies. Furthermore, other studies have indicated that there is need for enhancement of human capabilities through training, education and increased access to productive resources could lead to the diversification of skills, livelihood strategies and income sources of populations living in disaster-prone areas (Chambers, 1997; Boddington, 1996; GOK/UNDP, 1997 as cited in Suda, 2000).

##### ***Ignorance among Community members***

Accordingly, community members have been seen to the enemy of their own. This is because community members have sometimes not acted on the advice of the government. For instance, warning systems intended to warn the community members tend to be ignored. This can be seen when

the government has severally warned the residents dwelling near railway lines in areas such as Kibra. Various efforts for relocation have turned futile because of politicization process. Moreover, the water catchment areas that the government has tried protecting in the Mau area have turned political due to the fact that the community members have ignored the warning to move, yet environmentalists have warned against such instance of flooding in low land areas.

#### *Lack of Volunteers in curbing disaster*

Overreliance on government thus they lack independence in fighting disasters has been seen as the common norm for all Kenyans. Furthermore, volunteering has been to be lacking because of the urge for the community members to want to be paid for any job done. The need to emphasis on volunteering is seen as the main hope of fighting disaster in Kenya. The county governments should encourage free training and address the need to create fora and sessions that are sponsored by the county governments. However, formal structures for mobilizing communities by the county governments' are still inadequate and are in need of crucial responsiveness.

#### **Conclusion and Policy Recommendations**

The creation of the Disaster Management Policy (2010) is seen as a plan by the government to prevent major calamities from taking place. Moreover, there is need for mitigation and prevention strategies that have to be put in place to prevent further disasters from taking place. Furthermore there is need to encourage the county governance in ensuring that there is need for implementation of this policy and at the same time make sure that there are adequate measures fostering the adoption of new structures and guidelines to prevent and alleviate calamities in various counties.

This paper recommends the following as considerations by the county governments;

- 1) Utilization of the National Youth Service to meet the demand of staffing through negotiation by the national government

- 2) Introduced Basic first aid that should be made compulsory in various counties including education facilities among other institutions
- 3) County governance creation of a well-funded response unit and allocations of resources that counter disasters and at the same time to respond when there is catastrophe
- 4) Adequate sensitization and awareness created by the county government in ensuring that there is knowledge and information gained by community members. This knowledge should translate into action and more so provide an opportunity to learn so as to prevent disasters and at the same time act.
- 5) The citizenry need to change their perception about disasters as last minute result and further create initiatives that will enable them fight disasters.
- 6) Appropriate linkages between various organs that are directly geared towards disaster prevention and response. For instance, the police, the military, the hospital concerned with disaster prevention especially the referral hospitals
- 7) Policies need not only be in paper but also be put into practices with the existing structures, facilities and staffing in the county governments.

#### **References**

- Boddington, M.** (1996). Training issues for sustainable agriculture and rural development. In(S.A. Breth, ed.) *Integration of Sustainable Agriculture and Rural Development: Issues in Agriculture Policy*, pp. 143-152. Winrock International, Morrilton Arkansas.
- Chambers, R.** (1997). *Whose Reality Counts? Putting the First Last*. Intermediate Technology, London.
- GOK/UNDP.** (1997). Sixth Country Programme Evaluation Report. Nairobi, Kenya.
- Government of Kenya (GoK).** (2010). *Disaster Management Policy*. Government printers.

- Government of Kenya (GoK).** (2012). *National Disaster Draft Policy*. Government printers
- International Strategy for Disaster Reduction (ISDR).** (2002). *Living with risk: A global review of disaster reduction initiatives*. Preliminary version, Geneva: ISDR Secretariat.
- Nabutola, L. W.** (2012). *The Challenges and Opportunities for Integrated Disasters and Risk Management with Particular Reference to Policy, Legislation and Regulations in Kenya*. 8<sup>th</sup> FIG Regional Conference on Surveying towards Sustainable Development. Montevideo, Uruguay, 26 – 29 November 2012.
- Suda, C. A.** (2000). Natural Disaster Preparedness, environmental degradation and sustainable development in Kenya. *African Study Monographs*, 21 (3): 91-103.
- Thompson, R. L.** (1996). Incentives for sustainable agriculture and rural development. In (S. A. Brett, ed.) *Integration of Sustainable Agriculture and Rural Development Issues in Agricultural Policy*, pp. 87-99. Winrock International, Morrilton, Arkansas.
- Van Niekerk, D.** (2002). *An intersectoral model for disaster contingency planning*. Master's dissertation. Florida: Technikon SA.
- Vermaak, J. and Van Niekerk, D.** (2004) Disaster risk reduction initiatives in South Africa: Development Debate and Practice. *Development Southern Africa*, 21(3).

## Role of *Bodaboda* (Motorcycle and Bicycle) in Urban Transportation System in Kenya

By  
Jasper E. Nyaura<sup>1\*</sup> and Margaret N. Ngugi<sup>1</sup>

<sup>1</sup>Department of Peace, Security and Social Studies, Faculty of Arts and Social Sciences, Egerton University, P.O. Box 536-20115, Egerton-Njoro, Kenya

\*Corresponding author: [edward.nyaura@yahoo.com](mailto:edward.nyaura@yahoo.com)\* and [ngugi.magi@yahoo.com](mailto:ngugi.magi@yahoo.com)

---

### Abstract

Transportation in urban centers has improved tremendously with the introduction of the *bodaboda*. Moreover, 80% of the urban centers especially the Western, Nyanza and Rift-Valley region have seen the growth and usage of *bodabodas* serving the inhabitants of the various centers. *Bodabodas* are seen to serve the local inhabitants especially those moving from one station to the other (less than a kilometer). Furthermore, the *bodabodas* have brought about reduced unemployment in these urban centers. However, the *bodabodas* have been associated with accidents in various urban settings in which they operate in. This paper provides an analysis of the gains and challenges the *bodaboda* operators face with a view of understanding their environment in which the *bodaboda* operators, operate in. The recommendations put forward are that there should be regulations put in place to provide check and balances on the operators by the National Government and more so the county governments through a consultative fora. Moreover, the National government and the County government through consultations should incorporate the inclusive ideas of all stakeholders.

**Key Words:** *Bodaboda* (motorcycles and bicycles), challenges, transportation.

---

### Introduction

In the recent 21<sup>st</sup> century, transportation system has changed tremendously. The introduction of the *bodaboda* (bicycles and motorbikes) especially in the Western, Nyanza and Rift-Valley region among other regions in Kenya has seen its development and growth in various centers in the urban region. The deregulation of *bodabodas* has seen growth of motorcycles (Kamuhanda and Schmidt, 2009). Moreover, the Kenyan government zero-rated import duty on motorcycles and bicycles. However, the

decline in the organized public transport systems has led to a growth in largely unregulated, informally provided non-conventional public transport, the most dominant being the motorcycles, which is common public transport system. More so, the origin and growth of motorcycle taxis can basically be traced due to the collapse of bus transport services either directly provided by the state or contracted for, and the deregulation of the market leading to a growth in informal operators (Kumar, 2011).



According to Howe and Davis (2003), *bodaboda* provide three types of transportation services that include the short-distance services that include; within the main urban areas, where they compete with conventional sole hire taxis and *Matatus*; as feeders to urban areas on routes that due either to the low density of demand or the roughness of the route that are considered unattractive to *Matatus*; and eventually as feeders to the main roads in which role they tend to complement *matatu* and large capacity bus services.

The failure of the public provision of transport services led to the emergence of a Para-transit system operated by the private sector. The main mode of transport shifted from high capacity buses to minibuses, operated by individual private operators and managed by an association. However, private buses have not been able to meet the growing demand and substantial unmet demand remains, particularly in the remote areas and during off-peak periods. This has led to a growth of the motorcycle and the bicycles being the dominant form of non-conventional means of transport, which today is the most common form of informal public transport system on most secondary roads in the city especially in the estates and outside the business district (Kumar, 2011). However, using the desktop review methodology, the papers will critically analyze the benefits and challenges face in the *bodaboda* industry looking at the role that it has played in the urban transportation system in Kenya.

### **Benefits of the *BodaBodas* in the Current Context**

#### ***Reduced Unemployment Rates***

Studies by Goodfellow et al., (2012) point out that the *boda-boda* industry is also viewed as a source of employment for many unemployed and unskilled youth thus if the industry does not exist, there is the fear that the urban and rural youth may be drawn to dangerous, activities. As uneducated, low-

skilled men, they might easily become implicated in criminality or rebellion. In the Kenyan context the introduction of the *bodaboda* is seen as an opportunity and a chance for many youth to engage on income generating activity. Moreover, the poor especially those that are unemployed benefit from the operation of bicycle and motorcycle (*boda boda*) from the employment created, and using the services provided. The increase in rural-urban migration has seen the increased influx of persons who have ventured into the *boda-boda* form of transportation in Kenya. Furthermore according to studies by Mutiso and Behrens (2011) point out that with the growth of these *bodabodas* further improve the development of *bodaboda* garages where *bodabodas* will be repaired thus indirectly provides employment to those working on the garages.

#### ***Provision of an Alternative Transportation System***

Long before, persons who wanted to travel less than a kilometer could not afford taxis which were expensive and took more time in the traffic jams. The growth of the *bodabodas* has seen the affordable (motorcycles charging 50/= Kshs while bicycles charging an average of 20/= Kshs; may vary from one town to another depending on distance) and provision of alternative transportation system. The *bodabodas* have been termed to be faster as compared to the motor vehicle, for instance the some have been used to deliver goods from one point to another when there are *jams*.

#### ***Introduced Form of Organization among Group Members (Bodaboda operators)***

The *bodaboda* have introduced some form of organizations in form of the self help groups (commonly referred to *Chamas*) for instance studies by Mutiso and Behrens (2011) point out that in Nakuru all operators were found to be members of an operator association known as the Nakuru *Bodaboda* Group (NBG) which its function is to enforce 'operational discipline' on its members, to defend them when arrested by the county

council officials, and moreover negotiating disputes. Furthermore members are required to pay a fee that is used to sustain group activity. The paper acknowledges that the need for organized grouping among the *bodaboda* operators imply the need to build other group members capacity, for instance, members who contribute are given loans of which they can buy their own motor cycles and bicycles thus having an income which they can lead to develop their families and rural area. Other studies by Njenga and Maganya (1998) as cited in Mutiso and Behrens (2011) indicate some form of organized *bodaboda* transportation in Kisumu in the 1990's. Moreover, McCormick (2010) notes that there is the existence of associations in Kisumu in the year 2006.

#### ***Growth of Regulated Public Transport Systems***

Accordingly, in the absence of a conscious public policy to organize the market and provide well regulated public transport systems the diseconomies of the informal sector will grow and eventually compromise the very vitality and comparative advantage of a city. Motorcycle taxis could potentially provide a useful service as feeders from low density suburbs to main corridors together with taxis and micro-buses; but to fully exploit their potential, they need to be regulated and their operations integrated within the overall sector strategy. This will require an understanding of the sector governance or the institutions responsible for managing and regulating the sector, identify key stakeholders with vested interest in maintaining the status quo and those adversely impacted by the resulting distortions, and develop measures to improve information sharing and accountability. Moreover, while the standard recipes for improving the sector performance are well documented in theory, the operational utility of those prescriptions need to be understood in the context of vested interests and well established alliances. The growth of commercial motorcycles has importance to this argument, thus there is a need to develop a participatory framework driven by open communications across the

board among all the stakeholders. Proper strategic communication will build on the strong elements of the current operations while putting an agenda for change in place while developing ownership and managing any resistance. Such an approach will enhance acceptability, build stakeholder participation, and improve quality of decisions, making them reflect the interests of the public as a whole (Kumar, 2011).

#### ***Growth in Transport Demand***

Kumar (2011) points out that transport functions are closely inter-linked with job and housing markets; the growth in city population and jobs resulting in a rise in transport demand. Low-car ownership and limited road space will result in heavy dependence on public transport in developing cities. Furthermore, the poor delivery of organized formal public transport services results in a growth of informal public transport services; the growing size of informal sector makes it an economic and political force; vested interests are substantial and the political system is subverted to benefit a few.

#### ***Costs in usage by the low income persons***

Studies by Howe and Davis (2003) suggest that the household expenditure data suggests that the poorest stratum of the population only occasionally use *bodaboda* services, low incomes and the high unit cost of fares being the binding constraints to increased usage. However, those engaged in formal or informal sector wage employment seem likely to have received benefits from the enhancement of their income earning activities through the greater mobility afforded by *bodaboda* usage.

#### ***Speed and Convenience on the part of the Customers***

For both men and women it is the speed and convenience of motorcycles that seems to be most prized especially when: there are no taxis available, a door-to-door service is required, or the user is in a hurry. Some operators are equipped with mobile phones and hence can be summoned. Tiredness, wet

weather, terrain and security for women (relative to walking) are also usage factors. The main reasons for using bicycle-based services rather than motorcycle are to save money, due to the short distance travelled, and no other choice, especially in rural areas. Load carriage, availability, and acceptability of a slower journey were also given as usage factors (Kumar, 2011).

### **Challenges Facing the *bodaboda* Industry**

#### ***Increased taxes and Harassment by the County Government officials***

The introduction of new county governance system has seen the increase of levies collected by the county governments. More so, this has made many *bodaboda* operators not to pay the rates which have thus reduced the ability of the various county governments from providing services to its residents. Furthermore, the *bodaboda* operators have been seen to be harassed by the municipal council (the new County governments) where they in some cases are forced to pay hefty fines during crackdowns resulting to them not performing their duties effectively when they are with their passengers. However, the *bodaboda* operators are in some cases to blame because they themselves do not pay the required fees.

#### ***Squabbles among Members including Bodaboda Associations***

The introduction of SACCOs and self-help group registration has seen the formation of associations in various parts of counties. These associations have seen persons from different parts of the country joining these associations coming up with new ideas. More so, if new ideas are formed, they are subject to disagreements. As a result, differences from members in the self-help groups have seen members forming splinter groups which in most cases result to violence which in turn reduces the urge of consumers using the *bodabodas*.

#### ***Ownership of the bodabodas (costs in acquiring bodaboda)***

The cost of acquiring the *bodaboda* (motorcycle in most instances because they tend to be expensive and bicycle) by the operators tend to be cumbersome and in most cases they tend not to obtain credit facilities from banks because of lack of collateral. Furthermore, they tend to operate *bodabodas* as employees and not owners, thus in most cases the owner may take his/her property without any agreements because the type of job is temporal in nature. The *bodaboda* operators job that is temporal nature is in turn a challenge in them accessing credit facilities.

#### ***Perceived Increased Cases of accidents in urban areas***

Despite the best efforts of service delivery to the consumers, the *bodaboda* operators have a poor profile among users. Men complain of reckless, inexperienced driving and disdain for traffic rules. Accidents are certainly common with reckless driving and drunkenness alleged to be the main contributory factors (Amimo, 2001). Other studies have indicated that there is some evidence that casualties resulting from accidents involving *bodaboda* occur disproportionately to women (Amimo, 2001). It is not obvious why this should be the case other than their propensity to sit sidesaddle, which implies they are more easily ejected from the vehicles (Iga, 2002). Studies by Kumar (2011) further indicate that in spite of the growing importance of the motorcycles in the urban areas, some clear disadvantages have arisen from the perception of the public interest. The motorcycle growth has developed without adhering to safety prescriptions as contained in the traffic laws of the countries. Moreover, the distribution of motorcycles has been carried out without ensuring proper operator training and licensing by the concerned authorities. Furthermore, insurance is required in any motor vehicle and more so the motor bicycles, however, they do not in any have insurance that cover themselves and their passengers (Mutiso and Behrens, 2011).

### ***Inadequate Skills for Customer Relations and Non-respectful behaviour***

Vices associated with the *bodaboda* industry are quite a number, among them being dishonesty in overcharging, not having change and actively thieving; poor appearance and personal hygiene; and abusive and arrogant treatment of clients, and abrasive behaviour towards women. Moreover, there have been reported cases where the customers have complained about the rude behaviour and “*bad reply*” when in disagreement with the passengers.

### ***Misappropriation of fund meant for Households***

It has been reported that the *bodaboda* operators have been in some cases misused the money obtained after a job well done. More so, in most cases the *bodaboda* operators have ended up using the wages earned on prostitution and alcoholism. As a result, there have been cases of increased HIV/AIDS cases. Poverty is another factor that is seen as families whose breadwinner misappropriates the funds; the family ends up suffering due to lack of provision of basic needs.

### ***Inadequate Participation and Policy Formulation in support of the Sector***

Accordingly, the decline in public transport services combined with the growth in informal, unregulated taxis and commercial motorcycles can be attributed to a combination of weak institutions, inadequacy in the government interventions that actually distort transport markets, the lack of participation by the stakeholders and infrastructure deficiencies. Moreover, the weak and inadequately staffed institutions are unable to develop comprehensive strategic plans and regulate the markets efficiently leading to unplanned growth of service providers filling the vacuum or seeking to maximize private gains at the expense of the broader societal good. Effective delivery of urban transport services requires coordinated attention to urban growth policies and planning, construction

and maintenance of sufficient and adequate infrastructure, and regulation of transport services. However, the functions are seldom coordinated at the institutional level. Different ministries and agencies at different levels of government (national and county government level) are involved. Furthermore, the clear effect of widespread confusion in the respective stakeholder participation (both the national and the county government) in planning and regulation roles is poor accountability, lack of coordination, and diffusion of commitment at all levels towards the development and implementation of comprehensive transport strategies. Institutional weaknesses are the source of many observed failures in urban transport in developing countries” (Kumar, 2011).

### **Conclusion and Policy Recommendations**

The *bodaboda* industry has seen the growth of urban infrastructure development in the urban centre. Moreover, the increase in the *bodaboda* operations has seen the increased use of *bodaboda* where the various inhabitants have been able to adopt it as the cheapest form of transportation. The introduction of the *bodabodas* has also seen the crucial development of the youth especially the urban youth who have migrated in search of employment. They have gained fully from the sector thus reduced crime rates in most parts of Kenya.

Moreover, the *bodaboda* industry has seen the introduction of some form of organization among group member thus including the *chamas* that have seen the youth sharing ideas and protecting one another. Furthermore, the sector has favored passengers due to convenience on the part of consumers because of their availability and speed.

However, the industry has seen its fair share of challenges which entail harassment by the county government officials through introduces rates which are costly to the operators. Furthermore, the lack of interest by the financial intermediaries to promote

the sector has been seen to be lacking due to the lack of collateral. This is because in most cases the ownership of the motorcycle is seen as temporal thus they cannot access credit facilities. Moreover, the industry has been seen as the major contributor of accidents in urban centres thus is seen as a vice in the transportation sector. The flouting of traffic rules in the sector by the *bodaboda* operators is seen as a contributing factor of accidents and at the same time a bad reputation in the sector.

Furthermore, the negative perception of the *bodaboda* operators as persons whom are disrespectful is seen as another short-fall. This has seen some of the passengers using other forms of transportation. Misappropriation of household funds is seen as another factor where the operators have not fully used their wages appropriately thus increasing the levels of poverty. For instance, family not affording basic needs.

Finally, the inadequacy of government at both the national and county government to address the needs of the *bodaboda* operators has been seen to be lacking thus the sector unregulated, further providing no checks and balances. The lack of adequate policy formulation is seen as another factor whereby both the County governments and the national government has not done enough to address the transportation sector especially the *bodaboda* industry.

The paper recommends that there is need for all inclusive stakeholder participation that can address the possible solutions towards the *bodaboda* industry. Further, the recommendations put forward are that there should be regulations put in place to provide check and balances on the operators by the national government and more so the county governments through a consultative fora. Moreover, the National government and the county government through consultations should incorporate the inclusive ideas of all stakeholders. For instance the provision of fora between the police and the *bodaboda* operator towards traffic regulations and

more so safety needs toward the passengers. There is also need for proper education on basic financial management and customer retention among the *bodaboda* operators which can lead to job sustainability may be provided by the self-help groupings among other association.

## References

- Amimo, P.** (2001). Busia's wheels of survival. *Daily Nation*, Wednesday January 17, 2001
- Goodfellow, T., and Titeca, K.** (2012). Presidential intervention and the changing 'politics of survival' in Kampala's informal economy. *Cities*, 29 (4). pp. 264-270. ISSN 0264- 2751.
- Kumar, A.** (2011). *Understanding the emerging role of motorcycles in African cities: A political economy perspective*. The International Bank for Reconstruction and Development/The World Bank.
- Kumuhanda, R., and Schmidt, O.** (2009). Matatu: A case of the of the core segment of the public of the transport market of Kampala, Uganda, *Transport Review*, Volume 29, 129-142.
- McCormick, D.** (2010). *Personal communication*. Institute of Development studies, University of Nairobi.
- Mutiso, W., and Behrens, R.** (2011). 'Bodaboda' Bicycle taxis and their role in urban transport systems: a case studies of Kisumu and Nakuru, Kenya. 30<sup>th</sup> Southern African Transport Conference ISBN: 978-1-920017-51-4. Document Transformation Technologies cc.
- Njenga, P. and Maganya, J.** (1998). Bicycle taxis come to Western Kenya, *Habitat Debate*, Volume 4, No. 2, pp. 18-19.
- Pankaj, T.** (1991). Designing low-cost rural transport components to reach the poor. *Infrastructure Notes Transport No. RD-2. March, Washington, DC (The World Bank)*.

# Expected Role of Information Systems on County Revenue Collection by Homa Bay County Government, Kenya

By

**Odoyo Collins Otieno<sup>1\*</sup>**

*1; Department of Management Sciences, School of Business and Economics, Maseno University, Kenya*

*\*Corresponding Author: [ootieno@student.maseno.ac.ke](mailto:ootieno@student.maseno.ac.ke)*

---

## Abstract

This paper examined the expected role of Information Systems on county revenue collection of Homa Bay County Government, Kenya. Study objectives included establishing the relationship between internal control systems, Information Systems and revenue collection in Kenyan County Governments; and investigating whether Information Systems relate to effectiveness and efficiency of Revenue Collection. A structured cross-section survey was used to collect data from 2,007 individuals, of which 165 were County Government staff (The then Homa Bay Municipal Council staff) and 1,842 were traders in Homa Bay Township. The study found that: there is a relationship between Information Systems and both efficiency and effectiveness in revenue collection, there is a strong positive relationship between Internal Control Systems and revenue collection as reported by 97% of the respondents, and that resistance to change by the County Government staff was derailing the full implementation of Information Systems. The study is useful in reviewing the institutions' Act and statutes to cater fully for the integration of IS in the management activities of Homa Bay County Government, to managers at all levels, public sector, policy makers and scholars.

**Keywords:** Information Systems, IS, Revenue Collection, County Government, Homa Bay County.

---

## Introduction

Information System (IS) is a mechanism that helps people collect, store, organize, and use information (Odoyo *et al.*, 2013). According to Patterson (2005), an information system is a group of interrelated components that work to carry out input, processing, storage, output and control actions in order to convert data into information that can be used to support forecasting, planning, control, coordination, decision making and operational activities in an organization. The basic purpose of any information system is to

help its users get a certain type of value from the information in the system, regardless of the type of information that is stored or the type of value desired (Norton, 2006). Since the devolved governments are very important to the citizenry. They are the engines of growth and centers of development (Odoyo *et al.*, 2013). They provide cultural; educational; management, research, commerce and political services. They also do offer employment, best health facilities and boost the country's economy (UN-HABITAT, 2004). For instance, the

former City Council of Nairobi, which was the largest Local Authority in Kenya, produced more than half of the country's Gross Domestic Product (Oduyo *et al.*, 2013).

### Literature Review

The goal of Information Systems, was not only to provide citizens, economic organizations, companies and institutions with a range of excellent and effective services, but they also created a new form of citizenship based on the participation of all individuals in the provision of services and the decision-making process which was aided by the intensive use of new Information and Communication Technologies. Further Web service portals could constitute a useful means of offering the services needed by all users then and in the future. At the same time, they embodied a new opportunity for the deployment of ICT after the disappointing results of the new economy and the unfulfilled promise of a revolution in business and economic activities. ICT programs and e-governance policy initiatives had also gained international validity for the donor community as a catalyst of reforms in support of global development goals, including health, education, economic opportunities, poverty reduction and the environment (UNDP, 2003).

Various policy blueprints produced over the years argued that ICT was essential to increase transparency and accountability of government agencies, reduce transaction costs in service delivery and enhance participation of citizens, businesses and civil society in the workings of governments. Better accountability and improved transparency were the identified characteristics of good governance, and the latter became the *condition sine qua non* for the rich states and international agencies to supply aid to developing states (UN, 2002, 2003; UNDP, 2003). Innovations and reforms in the governmental and bureaucratic apparatus through the introduction of ICT and e-government were

therefore seen as important prerequisite for aid and global development policy initiatives (Ciborra *et al.*, 2005). Doll *et al.* (1983), argued that IS department experiences increased demands and responsibilities and that the IS group in such constantly changing environment needed to keep up with a number of expectations. They further stated that as a consequence, improvement of services, not only resources, was vitally important. Enhancing the efficiency and effectiveness of the systems delivery, integration, maintenance, etc., along with better organization and control of the other IS processes were some of the possible ways that the IS organization could follow to ameliorate performance. ICT could also be seen as recognition that policy and resource allocation processes needed to be opened beyond the closed circles of elites at the state level. But it was also possible to notice how new electronic capacities introduced in government have escalated to widen the scope and purpose of e-government. The aims were to devolve meaningful authority to local bodies, improve the capability of governments' agencies to transfer and exchange information, making them more accessible to citizens and to improve service provision, channeling citizens' and civil society's voices and increasing the accountability of their representatives to enable the move toward ICT enabled connected governance (UNDESA, 2008). In March 2004, the Government of Kenya launched an ambitious three year (2003-2007) E-government Strategy (GoK, 2004). The strategy was designed to achieve a set of goals and objectives, namely, to efficiently deliver government information and services to the citizens; to promote productivity among public servants; to encourage participation of citizens in government; and to empower all Kenyans in line with development priorities outlined in the 2003 – 2007 Economic Recovery Strategy for Wealth and Employment Creation (GoK, 2004).

Formerly, the Kenyan local governance system was composed of four tiers of Local

Authorities, namely: Cities, Municipalities, Towns and County Councils. These councils were corporate entities that were established under the Local Government Act Chapter 265. In addition to the Act, the LAs drew their legal powers from the Constitution of Kenya, other Acts of Parliament, Ministerial Orders and By-Laws. There were 175 LAs in Kenya as at the time of the study which included City Councils, Municipal Councils, Town Councils and County Councils with Ministry of Local Government as the overall overseer of their operations (Mitullah *et al.*, 2005). Most of these LAs faced a number of challenges in realizing their mandate. The challenges included: delivery of infrastructure and services, financial management, institutional and legal framework, human resource capacity and managing rapid growth. These challenges had resulted in poor service provision and management and many analysts had criticized the LAs, and questioned their role in local development. This inefficiency had justified a re-examination of their role and the launching of the Local Government Reform Programme, which also included the decentralization of service provision and management, which was still in the initial stages (Waema, 2005). In 1996, a decentralization initiative under the Local Government Reform Programme was launched focusing on strengthening LAs. The programme had three components: rationalizing central-local financial relations, improving LA financial management, including revenue mobilization, and strengthening citizen participation in planning and ownership of programmes. The reform programme had recognized the importance of Local Authorities in enhancing economic governance, improving public service delivery, and increasing economic efficiency, accountability and transparency (GoK, 1999). The reforms had also included putting in place Fuel Levy Fund, Contribution in Lieu of Rates, user charges rationalization, single business permits and most greatly Integrated Financial Management System (IFMS). These programs aimed at restructuring the

local public sector and more importantly, strengthening local level accountability mechanisms. The Kenya Local Government Reform Programme (KLGRP) was conceptualized by the government of Kenya in the early 1990s and became operational in 1996. KLGRP focused on deepening the legal, financial management and institutional reforms in Local Government sector. KLGRP began with financial reforms aimed at enhancing inter-governmental fiscal transfers, improving financial management, debt resolution, streamlining budgeting system and service provision capacity building for Local Authorities. A key instrument in this process was the enactment of the Local Authority Transfer Fund (LATF) in 1998. The act provided 5 percent of national income tax to Local Authorities in line with population, resource base and financial performance (GoK, 1999). According to Stephen *et al* (2000), Control was the process of monitoring activities to ensure they were being accomplished as planned and correcting any significant deviations. This definition gave a brief but all inclusive definition. It indicated that control aimed at monitoring the activities to ensure that they are completed in ways that led to the attainment of the organization's goals. They further argued that effectiveness of the control system depends on how well it facilitates the organizational goal achievement.

The County Governments are therefore taking over from where the Local Authorities left. The promulgation of the Constitution of Kenya 2010 (CoK, 2010) on 27 August 2010 paved way for realization of the "dream" system of governance. Chapter Eleven (Cap 11) of CoK 2010 – Devolved Government specifically provides for the setting up of the County Governments. Chapter spells out the various principles of devolved government that includes democratic ideals and the separation of powers. County governments will be facilitated reliable sources of revenue to enable them govern and deliver services effectively.



Certified Public Accounts Research (1990) defined internal control as “the plan of organizational and the coordinated methods and measures adopted within a business to safeguard its assets, check the accuracy and reliability of its accounting data, promote operational efficiency and encourage adherence to prescribed management policies.” Donald *et al* (1994), viewed internal control as a structure that comprises three elements, which are: the control element which entails management philosophy, organizational structures, the functions of the board of directors, management control, and personnel management methods; the control procedures which consist of policies and procedures that the management has established to provide reasonable assurance that specific objectives will be achieved; and the accounting system which refer to the methods and records established to identify, assemble, classify record and report an entity’s transactions and maintain accountability for related assets and liabilities. This gives a view that internal control system extend beyond those matters which relate directly to the functions of accounting and financial departments; it thus incorporates both financial and non financial controls. System controls in a computerized environment are classified as either general or application controls. General controls are designed to manage and monitor the system environment, thereby affecting all system related activities. They include control aspects such as segregation of duties, assignment of authority, management integrity and corporate governance, software acquisition and maintenance, physical and online security, access to data, and contingency planning- anything that involve entity-wide system concerns (Guldentops, 2001; COBIT, 2002). The primary objective of application controls is to ensure the accuracy and integrity of specific applications such as sales order processing or accounts payable. They include input, processing, and output controls within an application. Input controls relate to the data that is entered into the system; processing

controls relate to transformation and output controls work to ensure that the processed data is distributed and utilized appropriately by authorized users for authorized purposes (Hall, 2002). General and application controls are interrelated and always taken together; they serve to ensure validity, accuracy, and completeness of financial of financial information produced by the current internal information system of an entity. System controls need to be understood as they relate to management’s assertions, and regardless of their strength, their operational effectiveness needs to be evaluated (COSO, 1999; COBIT, 2002).

According to the study by UN-HABITAT (2010), on fundamental problem of municipal finance in Africa, which can be stated as the gap between financial resources and municipal expenditure needs coupled with inadequate financial systems. The study revealed that fiscal gap is widened as urban populations expand, increasing the demand for infrastructure and urban services. It was evident on the research findings that there exists lack of (municipal) income elasticity, the fact that the growth of municipal revenue does not match the increase in urban economic activity. The study further revealed that taxing powers of local authorities are not wide enough and the yield from existing sources is often far inadequate to meet their expenditures. The study also found out that many cities in Africa largely depend upon income derived from property taxation and other service charges, while other and more lucrative sources, such as income tax, sales tax and business tax are monopolized by central governments. Thus, many cities have to depend on central government allocations, which are generally inadequate and often erratic in terms of timing. The study also reveals that a common source of revenue in most countries is inter-governmental transfers.

### **Methodology**

This study adopted a survey research design where primary data were collected from

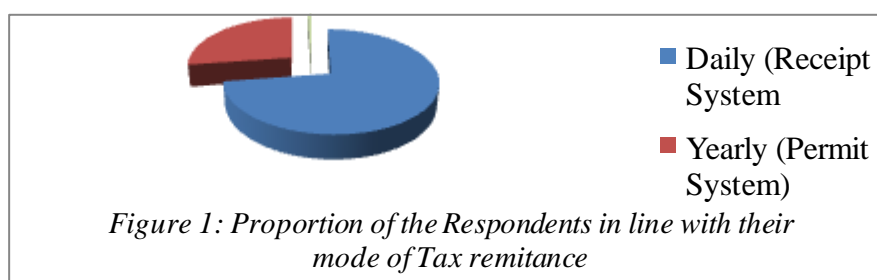
selected sample through questionnaires. This research design was preferred because it enabled the researcher to collect data from samples by administering well prepared questionnaires, which captured different aspects of Information Systems from opinions of the respondents. Stratified random sampling was employed to arrive at 116 County Government staff (the then Homa Bay Municipal Council) and 318 traders giving sample of 434 individuals from a population of 165 County Government staff and 1842 traders in Homa Bay Town Sub-County as at the time of the research. Both the primary and secondary data were used and analysis was done using the frequency distribution technique.

### Findings and Discussion

The results from the study showed that the County Government had adopted the use of ICT in the year 2013 when the study was conducted in the form of Integrated Financial Management Information Systems (IFMIS). This was evidenced from 96.3% of the responded who ascertain adoption of ICT by Homa Bay County Government and only 3.5% disagreed. This meant that the County Government had enough ICT components necessary to support the

operations within the County Government. This was so since both the traders in Homa Bay town and the County Government staff had a common opinion on County Government adoption of ICT. Further the County Government had adopted Information System in Revenue Collection. From the results of the study, more than 96% of the respondent in their response stated that Homa Bay County Government applies Information Systems in Revenue collection.

Information systems had also taken revenue collection of Homa Bay County Government to the next level, by boosting their revenue collection. However, more still needed to be done in terms of designing an appropriate method, for collection of revenue from those traders that remit their taxes on daily basis, or attract them using other means such as categorizing payment modes into; yearly or probably monthly payment mode which can be easily computerized as the permit system was. The number of traders that remit their taxes on daily basis was quite big accounting for over 70% of all the traders who participated in this study as shown in Figure 1.



**Figure 1: Proportion of the Respondents in line with their mode of Tax Remittance**  
Source: Respondents' Scores, 2013

The study also showed that Information Systems that the County Government had installed maximized revenue collection, especially the permit system where records were easily captured. From the entire sample population, over 90% of the respondents

stated that Information Systems attributed to maximization of revenue collection of Homa Bay County Government. This further showed how efficiency and effectiveness of revenue collection had a strong positive relationship with the use of Information Systems as shown in Table 1.

**Table 1: IS maximizes Revenue Collection**

	<b>Frequency</b>	<b>Percent</b>
Strongly Agree	44	10.1
Somewhat Agree	211	48.6
Agree	159	36.6
Disagree	14	3.2
Strongly Disagree	6	1.4
<b>Total</b>	<b>434</b>	<b>100.0</b>

Source: Respondents' Scores, 2013

The study showed the respondents opinions concerning financial controls with the influence of ICT. Over 85% of the respondents were of the view that adoption of ICT had indeed enhanced tighter financial control within Homa Bay County Government. From the study, 80% of the respondent believed on the positive impact that Information system had on financial control. This strong positive impact led to even an improvement of management integrity, as the system streamlined services to suit both staff and clients who were the traders. Generally 97% of the respondents indicated that indeed, information systems had improved the integrity of the management of Homa Bay County Government, probably due to the enhanced financial control that the same information system is a factor to.

Contrary to the first two objectives, the study revealed that even though the County Government had adopted use of ICT in most of their operation such as revenue collection, the quality of services offered by Homa Bay County Government still remained at very low levels. The traders were not satisfied with the kind of services that they receive from the County Government owing to the heavy taxes that they paid. More that 61% of the respondents on responding to whether the Information systems did improve the quality of services offered to clients by the Homa Bay County Government, disagreed. The % age showed the level of dissatisfaction that the traders had on the County

Government service provision. The lower levels of the quality of services offered by the County Government could be attributed to the low commitment that the County Government staff had on using Revenue Information System. As the study revealed, all the computer hardware and software that were necessary to support the County Government operations in serving the clients were available. What missed out was the commitment in effectively using ICT. The study further revealed that the County Government did not base their decision making on the records provided by the information system (Integrated Financial Management Information systems-IFMIS). This therefore meant that most records provided by the IFMIS were formality since the government, specifically the national controller of budget insisted on the use of this ICT tool in the public service provision. Finally, the study also established that the complaints made by the clients did not decline even after the County Government had installed ICT systems. This was an indication of status quo by Homa Bay County Government on their activities. This compares so well with the challenges posed by Mitullah *et al* (2005) on the *State of ICTs and Local Governance in Kenya* that revealed Local Authorities playing a central role in local economic development in Kenya, but faced a number of challenges which included collection, storage and dissemination of information. Most of these authorities, like others in Africa, rely on manual file based information storage with hardly any dissemination taking place. They further

revealed that Local Authorities faces a number bottle necks while discharging their duties due to the fact that ICT facilities are still limited in Local Government Institutions and also technical skills on how to apply ICT is still very low. The latter seems to compare well with the situation of Homa Bay County Government.

### **Conclusion**

Based on the research findings, the study concluded that investment in ICT is very important to County Governments. Computerized Information Systems has a positive effect on revenue collection. Computerization of County Government activities such as revenue collection enhances efficiency as a result of timely revenue collection, enhancing management integrity, provision of clear records among other factors. Information systems also improve the operations that are facilitated by the Internal Control Systems which in turn enhances efficiency and effectiveness of the County Governments.

The study confirmed that Internal Control Systems relate to revenue collection. Tighter Internal Control Systems have positive relationship with revenue collection. It was further established that Information Systems enhanced tighter financial control of Homa Bay County Government. This was further established to have increased management integrity according to how both the County Government staff and the public perceived the management and governance of Homa Bay County Government especial with respect to public participation. The study also found out that even though the County Government had adopted use of Information systems (Integrated Financial Management Information Systems – IFMIS) on revenue collection exercises, budgeting, reporting, and other operations, quality of services offered by the County Government were still very low. Study further established that the County Governments lacked commitment to fully utilizing Information Systems and ICT in general in carrying out their operations. Specifically it was found that the County

Government did not base their decision making in many occasions on ICT based records even though such records were available. This was an indication that ICT adoption was a formality since the central government, specifically the national controller of budget, insisted on all Government Ministries and Departments to adopt ICT including all County Governments. As a result complaints made by the public and clients were on the rise even after the adoption of Information System and ICT in general. The study was recommended to be useful in reviewing the institutions' Act and statutes to cater fully for the integration of IS in the management activities of Homa Bay County Government, to managers at all levels, public sector, policy makers and scholars. Finally, the researcher recommended the following areas for further study consideration; the staff's attitude towards the adoption of ICT in County Governments in Kenya and establish if they fully embrace the use of ICT, the degree of computerization of revenue collection exercises and its cost-effectiveness, and the impact of Internal Control Systems (ICS) on revenue collection of County Governments.

### **Acknowledgement**

I acknowledge with sincere gratitude the contribution, support, and commitment of my supervisors, Dr. Moses Oginda and Mr. John Mark Obura, to whom I am indebted. They tirelessly put in their expertise, time and effort in going through my work and giving direction and advice throughout the entire research process. I thank Mr. Johnson K'Obiero who is the director, Homa Bay Town Campus, Maseno University and Mr. Alphonse Odondo of school of Business and Economics, Maseno University for their special and kind advice that helped me go through this study. I also thank the Dean School of Business and Economics, Maseno University, Dr. Patrick Ojera for his support, members of staff and fellow MBA students from Homa Bay Town Campus, Maseno University for their encouragement. I sincerely thank the respondents of this study for their valuable support that made this

study a success. Above all, I thank the Almighty God for the health, amazing grace and strength, especially during the time of this study.

## References

- Ciborra, C., and Navarra, D. D.** (2005). Good Governance, Development Theory and Aid Policy: Risks and Challenges of E-Government in Jordan, *Information Technology for International Development*, 11(2), 141–159.
- COBIT.** (2002). *Control Objectives for information and Related Technology (COBIT)* (3rd Edition). Information Systems Audit and Control Foundation (ISACF).
- COBIT.** (2002). *Control Objectives for information and Related Technology (COBIT)* (3rd Edition). Information Systems Audit and Control Foundation (ISACF).
- CoK.** (2010). *The Constitution of Kenya*, Government Printers.
- COSO.** (1999). Research Prompted by the Committee of Sponsoring Organizations of the Treadway Commission, *Fraudulent Financial Reporting, 1987-1997. An Analysis of U.S. Public Companies*.
- Doll, W. and Ahmad, M.** (1983). *Management Users' expectations*, *Journal of Systems Management*, Vol. 34, pp. 8-11.
- Donald, H. T. et al.** (1994). *Auditing-Integrated Concepts and Procedures*, 6th Edition, John Wisely and Sons, inc. NY.
- Government of Kenya.** (2004). *E-Government Strategy: The Strategic Framework, Administrative Structure, Training Requirements and Standardization Framework*, Cabinet Office, Office of the President, Nairobi: Government Printer.
- Gulentops, E.** (2001). Harnessing IT for secure, profitable use, *Information Systems Control Journal*, Vol. 5, pp.45-47.
- Hall, J. A.** (2002). *Information Systems Auditing and Assurance*, South – Western College Publishing.
- Mitullah, W. V. et al.** (2005). *Management of resources by local authorities: The case of Local Authority Transfer Fund*. Nairobi, CLARIPRESS.
- Norton, P.** (2006). *Introduction to Computers*. McGraw-Hill Technology Education, China.
- Odoyo C. O., Oginda M., Obura J. M., Aila F. O., Ojera P. B and Siringi, E. M.** (2013). *Effect of Information Systems on Revenue Collection by Local Authorities in Homa Bay County, Kenya*.
- Republic of Kenya.** (1999). *Report of the rationalization and staff rightsizing for effective operation of the Ministry of Local Government*. Nairobi: Government Printer.
- Stephen, P. R. et al.** (2000). *“Management”* Prentice Hall, 5th Edition, India.
- United Nations.** (2002). *E-government for development: Final Communiqué of the International Conference on E-Government for Development*, Palermo.
- United Nations.** (2003). *First Annual Report of the Information and Communication Technologies Task Force*, Economic and Social Council of the United Nations, Retrieved 14 March, 2012, from [http://www.ictdevlibrary.org/downloads/un\\_ict\\_task\\_force\\_first\\_ict\\_report.pdf](http://www.ictdevlibrary.org/downloads/un_ict_task_force_first_ict_report.pdf)
- UNDESA.** (2008). *United Nations e-government survey 2008*, New York: Department of Economic and Social Affairs Division for Public Administration and Development Management.
- UNDP.** (2003). *Information and communication technologies for development in human development reports*, New York: United Nations Development Programme.
- UN-HABITAT.** (2004). *Challenges of Municipal Finance in Africa*, Nairobi: United Nations Human Settlements Programme.
- UN-HABITAT.** (2010). *Challenges of Municipal Finance in Africa*, Nairobi: United Nations Human Settlements Programme.
- Waema, T. M.** (2005). In Etta, F. E. and Elder, L. (eds.) *A brief History of the*

Development of ICT policy in Kenya. (At  
the Crossroads: ICT policy making in

East Africa, pp. 25-43) Nairobi, Kenya:  
East Africa Educational Publishers Ltd.

## Socio-Economic Factors Influencing Smallholder Maize Production in Migori County, Kenya

By

Ojala, D. O.<sup>1\*</sup>, Nyangweso, P. M.<sup>1</sup>, Mudaki, J. S.<sup>1</sup>, Zablun E.<sup>1</sup>, Korir M.<sup>1</sup> and Kiano, E. K.<sup>1</sup>.

<sup>1</sup>*Department of Economics, Moi University, Eldoret, Kenya*

*\*Corresponding author: [daphenoj07@gmail.com](mailto:daphenoj07@gmail.com)*

---

### Abstract

Maize is the main staple food crop in Kenya and is of vital concern to agricultural policy decisions, food security and overall development of the sector and the economy. It is also the dominant staple food crop in Migori County. However, there has been a declining trend in maize production among farmers in Migori County, a tobacco growing zone, threatening household and national food security. This paper examines socio economic factors influencing smallholder maize production in Migori County. A survey was conducted among all smallholder maize farmers in tobacco growing zones of Migori County. A multistage sampling technique was used. A sample of 165 maize farmers was selected using systematic random sampling. Descriptive statistics such as measures of central tendency, cross tabulation, tables, and bar graphs as well as regression were used to analyze data. Results show that farmer's age - a proxy for experience, resource base as captured by size of cattle herd, total cropped area and competition from tobacco production influence maize production. Efforts to improve maize production in Migori County should improve resource base of farmers, pay attention to their experience and consider competition for scarce production resources.

**Key words:** Smallholder, Maize Production, Tobacco Farming, Constraints, Migori County, Kenya.

---

### Introduction

Maize is the main staple food crop in Kenya and is of vital concern to agricultural policy decisions, food security and overall development of sector and the economy. Maize production in Kenya is a highly relevant activity due to its importance as it is a dominant food crop (Mantel and Van Engelen, 1994). The maize subsector is faced by four main challenges namely: low productivity; low value addition; under-

developed and inefficient factor and product markets and inefficient land use (Olwande, 2012). Efforts to increase maize production must take note of these challenges and endeavor to institute mitigating measures.

The Kenyan government policy objective for the maize sub-sector is to encourage increased production so that self-sufficiency and food security can be achieved. This is critical since over 85 percent of the rural

population derives its livelihood from agriculture, most of who engage in other cash crop production such as tobacco, ignoring maize production, yet it accounts for roughly 20 percent of gross farm output from the small-scale farming sector (Jayne *et al.*, 2001). Nearly all agricultural households plant maize and small-scale production dominates over 70% of total maize production (Olwande, 2012). However, there is stagnation in maize production and productivity in Kenya as evidenced by the increasing gap between production and consumption and the increasing frequency of supply shortages.

The incidence and intensity of hunger and malnutrition has increased significantly and per capita supply of the main staples has been declining since the early 1980s. Chronic under-nutrition is the most common form of malnutrition in Kenya and is mainly associated with insufficient dietary intake because households lack adequate resources (income) to secure basic food requirements. In 1994, the prevalence of chronic under nutrition among children under five years had risen to 34%, a level that is 15 times higher than that expected in a healthy, well-nourished population. The observed trend of under-nutrition at the national level corresponds with the decline in per capita food availability, declining economic performance especially in small-scale agriculture, and rising levels of poverty. Chronic under-nutrition does not affect all children uniformly in the country and the national estimates shows regional variations.

Maize is also the dominant staple in Migori County. However, there has been a declining trend in maize production among farmers in Migori County, a tobacco growing zone, threatening household and national food security. To make matters worse, almost all the arable land is under cultivation in Migori County making future increase in maize production to depend on yield improvement rather than expansion in area under production (Karanja and Oketch, 1992). Similarly, although Migori County is home

to tobacco production, many farmers live in abject poverty and are vulnerable to food insecurity thus making many to question whether switching from maize to tobacco is worthwhile. In addition, children in Migori County were the most vulnerable to malnutrition with half of them suffering from chronic under nutrition (Horizon, 2011). This paper examines socio economic factors constraining smallholder maize production in the tobacco growing regions of Migori County.

## Materials and Methods

### *Study Area*

The study was carried out in Migori County, which is in Nyanza Province of Kenya. It has a total population of 917,170 persons and covers an area of 2,597 km<sup>2</sup>. The presence of Lake Victoria, Migori and Kuria rivers and the relatively good weather patterns in Migori County have allowed the soils in the region to be well drained, making the county conducive for agriculture.



**Figure 1: Map of Migori County, Kenya**

### *Data sources and collection*

Data was collected through a farm household survey. Primary data was used in the study with a bit of supplementation from secondary sources. The data collected included quantities of maize and other food



crops produced, inputs used and other socio-economic characteristics of respondents. All smallholder maize farmers in Migori County were targeted. A sample of 165 respondents was selected based on the formula provided by (Cochran, 1977) for calculating the sample size from a population which is estimated to be greater than 10,000. Multistage random sampling was used within the study area and respondents selected using systematic random sampling. The unit of analysis was the farm household. The divisions where tobacco is grown were first delineated before respondents being selected in proportion to the number of farmers in the division. A mixture of interviews and administration of structured questionnaires were used to retrieve data from respondents. Key informants were also interviewed to form an opinion on the issue under study.

## Methods of Data Analysis

### Theoretical model

This study was based on the theory of production. Producer's objective in a classical sense is to maximize output so as to reap more profits (Varian, 1992; Jehle *et al.*, 1998; Mas-Collel, 1995). Such behavior can be modeled using a production function approach, profit function approach, cost function approach, or through mathematical optimization and dynamic programming. Given price taking, profit maximizing and a model of the physical production process, it is possible to derive a model of producer output and input decisions. However, it is important to note that some small scale farmers producing maize on a subsistence basis may be driven by other objectives other than maximization of profits.

It was assumed that farmers optimized their output subject to the cost of inputs employed in the production process. The myriad of possible inputs are usually grouped into five: raw materials, machinery, labor services, capital goods and land. These inputs can either be variable or fixed where resource allocations and distributive efficiencies in the

mix of input investment vary from one farmer to the other and according to available technology. According to Varian, (1992) and Wanzala *et al.*, (2009), if the aggregate production possibilities set by farmers is  $Y$ , then the aggregate production possibilities set is the sum of the individual production possibility sets and can be written as  $Y = \sum_{j=1}^m y_j$  where each production plan  $y_j$  is in  $Y$ . Hence,  $Y$  represents all production which is achieved from each production plan  $y_j$  distributed among farmers  $j = 1, 2, 3, 4 \dots m$ . Since a huge chunk of maize production is consumed within the household, production function approach to analyzing farmers' production decision is appropriate.

### Empirical model

The functional forms that may be chosen to model producer behavior include: Cobb-Douglas (Strauss, 1986; Varian, 1992), Translog (Christiansen *et al.*, 1973) and CES production functions. The Cobb-Douglas production function is given in (2.1) as: -

$$y = A \prod_{i=1,n} x_i^{\alpha_i} \tag{2.1}$$

Where  $A$  is a scalar for productivity,  $\alpha_i$ , is a parameter for each factor used and the sum of  $\alpha_i$  is the scale parameter,  $s$ . This functional form is attractive because of the simplicity of cost shares functions ( $S_i = x_i w_i / c(y, w) = \alpha_i$ ), unit elasticity of substitution, simple estimation and embodiment of technological progress in the model (Yanikkaya, 2004). The study considered a farm that is producing a non negative output  $Q$  hence having a flow of the output being produced from the inflow of 13 variable inputs  $X_i$  ( $i = 1, 2, 3 \dots 9$  and  $j = 1, 2, 3 \& 4$ ). The production function which specifies the maximum output obtainable from the input mix can be written as;

$$Q = f(x_1, x_2, x_3, \dots, x_n) \tag{2.2}$$

The general form of the estimated Cobb-Douglas production function is given by (2.3);

$$Q = \beta_0 \prod_{i=1}^9 X_i^{\beta_i} e^{\left( \lambda_j \sum_{j=1}^4 Z_j + \mu \right)} \dots \quad (2.3)$$

Where Q is the maize production in tonnage, Xi's are the input variables in maize farming while Zj's are the qualitative variables. When the model is log transformed it becomes (2.4);

$$LNQ = LN\beta_0 + \sum_{i=1}^9 \beta_i LNX_i + \lambda_j \sum_{j=1}^4 Z_j + \mu \quad (2.4)$$

Where: X<sub>1</sub> = total cropped area in acres; X<sub>2</sub> = labor in man hours; X<sub>3</sub> = capital in Kshs; X<sub>4</sub> = age in years; X<sub>5</sub> = fertilizers(tones); X<sub>6</sub> = poultry number; X<sub>7</sub> = number of cattle; X<sub>8</sub> = area under tobacco production (acres); X<sub>9</sub> = household size; z<sub>1</sub> = gender of the household head; z<sub>2</sub> = occupation of the household head; z<sub>3</sub> = division of residence; z<sub>4</sub> = education level and μ = error term.

Descriptive statistics such as comparison of means, cross tabulation, tables, and bar graphs were used to give a general description of the socio-economic profile of respondents. Regression analysis was used to determine the factors influencing production of maize. SPSS software was used to analyze the data.

## Results and Discussion

### *Socio-economic Characteristics of the Sample*

The major indicators as discussed include; farm size, poultry, sheep, cows, household size, age, tobacco area and maize acreage (Table 1).

The youngest farmer in the study area was 20 years while the oldest was 88 year with an average age of farmers being 41 years. This shows that the population of Migori County is relatively young. The average household size was 5. However, some households reported as high as 18 members which, was

attributed to polygamous tendencies among some families.

The average farm size was 5 acres, with some households owning as low as 0.3 acres and as high as 38 acres. This definitely demonstrates how land is a scarce resource in the county and continues to experience more pressure from the surging population. Despite growing tobacco on an average of 1.1 acres of land, farmers in Migori County find it necessary to allocate slightly more land area to maize on average 2.3 acres. This shows how maize is key a food security crop in the county.

The results also show that an average household in the county owns 4 heads of cattle, 1 sheep, 1 goat and 12 poultry animals. However, there were reported cases of some households who owned no livestock or owned above the average number. The general implication of this is that majority of households had a poor resource endowment which could alter acquisition of inputs.

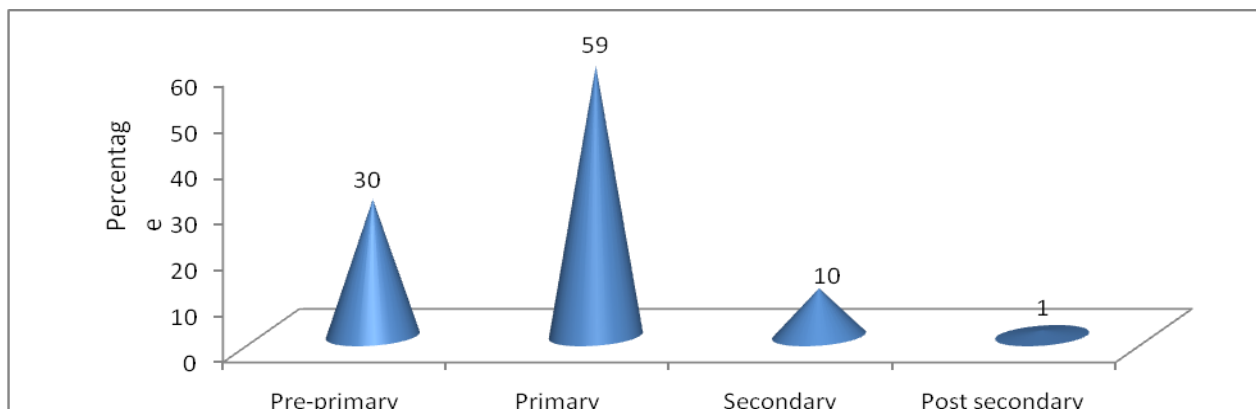
**Table 1. Sample Characteristics**

Variables	N	Minimum	Maximum	Mean	Std. Deviation
Age of Respondents	165	20.0	88.0	41.4	13.0
No. of Household Members	165	1.0	18.0	5.1	3.0
Total Farm Size in Acres	165	0.3	38.3	5.0	4.4
Tobacco Area in Acres	165	0.0	5.0	1.1	0.8
Maize Area in Acres	165	0.0	37.5	2.3	3.2
Number of Bullocks	160	0.0	8.0	1.6	1.8
Number of Local Breed Sheep	165	0.0	20.0	1.1	2.6
Number of Local Breed Goat	163	0.0	20.0	1.2	2.5
Number of Cows	165	0.0	22.0	2.6	3.7
Number of Layers	165	0.0	87.0	12.4	13.1

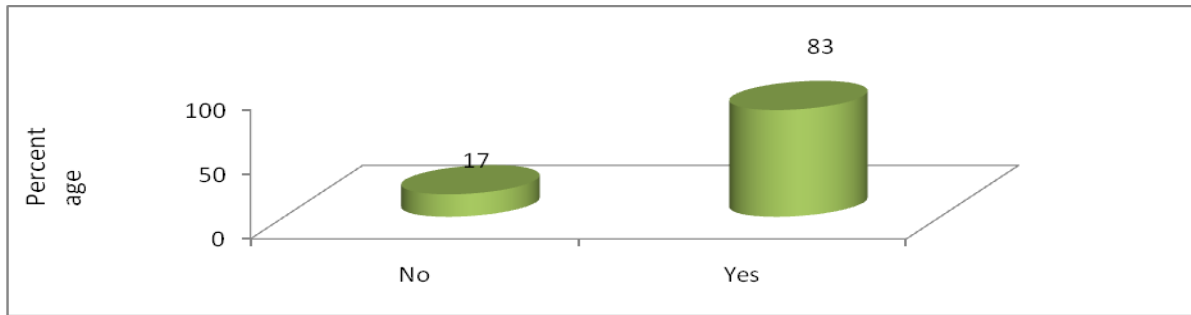
Figure 2 shows the highest level of education attainment across the study area. Results show that about 89 percent of respondents did not go beyond primary school, implying that they are either semi illiterate or totally illiterate.

This could derail adoption of new production techniques because of poor understanding and interpretation extension messages.

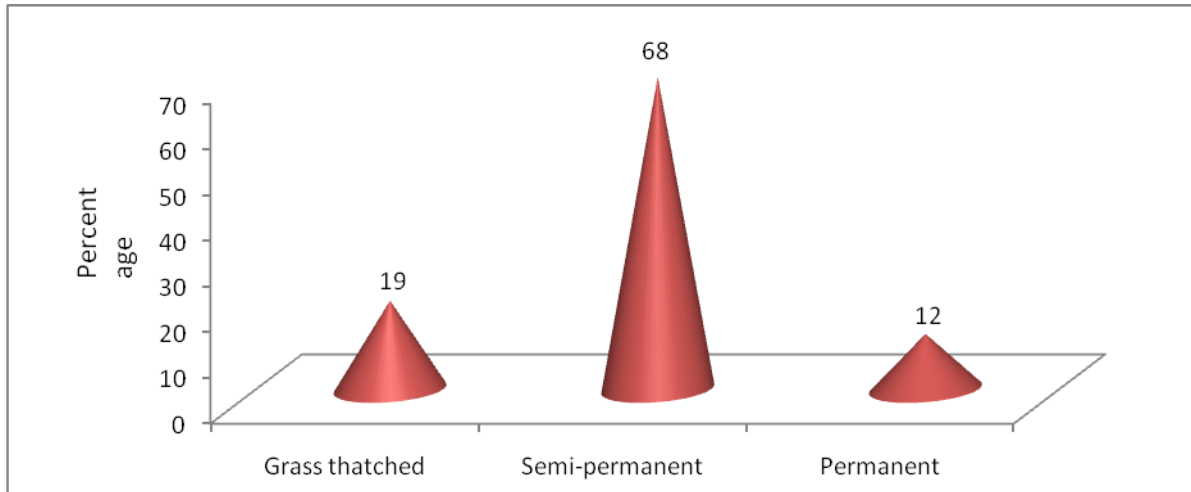
Tobacco is a cash crop and is expected to give high returns to farmers. Incidentally, about 83% of the farmers in the study area grew tobacco on their farms (Figure 3), implying that tobacco and maize have to share the available land. However, when asked about the type of house they resided in, a majority of respondents (68%) resided in semi permanent houses while 19% of respondents stayed in grass thatched houses (Figure 4) implying that despite growing tobacco they continued to wallow in poverty.



**Figure 2. Education Level: It will be important to provide a detailed legend for the figure to allow a standalone status.**



**Figure 3. Number of Farmers who Grew Tobacco: Provide a figure legend.**



**Figure 4. Type of Houses: Provide figure legends.**

When asked about the profitability of tobacco farming, 73% (Table 2) of respondents considered it to be unprofitable, which is contrary to the view of the establishment and pronouncements by the industry that tobacco farming in South Nyanza region is profitable. A general view among farmers was that returns from

tobacco growing were not commensurate with the efforts that they were putting in its production and tobacco companies were exploiting their cheap labor and using dirty tactics that keep farmers perpetually indebted to them.

**Table 2. Profitability of Growing Tobacco**

Response	Frequency	%
No	120	73
Yes	45	27
Total	165	100

Table 3 shows regression results for maize production among smallholder farmers in tobacco growing area of Migori County. It indicated that the goodness of fit of the

model was satisfactory. This is supported by  $R^2$  value of 0.602 implying that 60.2% of the variation in Maize production was explained by the model.

**Table 3. Regression Results**

Variables	Coefficients	Std. Error	t	P- Value
(Constant)	-2.795	1.825	-1.531	.129
LN (Age) <sup>2</sup>	.278*	.124	2.248	.027
LN Cattle	.235*	.086	2.743	.007
LN Labour	.038	.133	.287	.775
LN Capital	-.135	.098	-1.382	.170
LN Fertilizer	.081	.096	.837	.405
LN Household Size	-.085	.095	-.890	.376
Gender of Household Head	.293	.167	1.754	.083
LN Area under Tobacco	-.262*	.130	-2.016	.047
LN Total Cropped Area	.729*	.104	6.990	.000
Residential Division	.029	.025	1.164	.247
LN Poultry	.116	.074	1.556	.123
Highest level of education	-.015	.099	-.150	.881
Occupation of Household Head	.183	.134	1.366	.175

R= 0.776; R<sup>2</sup> =0.602; Adjusted R<sup>2</sup>=0.549; F= 11.290; \* Significant at 5%

From the data presented, a reader cannot infer anything or derive meaning of any values presented based on co-efficient. Besides representing a 'goodness of fit of the model' about the data as you correctly mention, there is no real meaningful information that can be deduced from the table. In essence, the data presented cannot be used to infer any relationship (positive or negative) between variables. It will be important to a right regression analysis that be used to deduce inter and intra relationships between and across variables.

Age of the farmer was significant and positively influenced maize production in Migori County. The implication for this is that as farmers advance in age, they gain more experience in maize production. Efforts to increase maize production should therefore pay attention to experience of stakeholders since it informs their decision on production. This is consistent with findings by Mignouna *et al.*, (2010) that experience provides benefits of hindsight that is useful in decision making.

Similarly, the size of cattle herd and cropped area which were indicators of asset base of farmers were highly significant and positively affected the quantity of maize produced. This implies that better endowed farmers resource wise are likely to do better in maize production in Migori County since they can use such endowments to access essential production inputs.

Area under tobacco negatively and significantly affected smallholder maize production. This clearly indicates that tobacco production in Migori County competes for land, a scarce resource, with maize. Therefore despite misgivings by farmers, tobacco represents a big threat to maize production in Migori County. Tobacco farming seriously competes for the meager piece of land with maize production yet it degrades the environment and its returns were not commensurate with the farmer's effort. Similarly, residents depend on wood fuel for curing tobacco despite a small proportion of land allocated to tree planting. This leads to environmental degradation and fluctuations in the amount

of rainfall received exposing the county to crop failure.

However, gender, geographical location, education and occupation were not critical determinants of maize production in the county. This is inconsistent with Mignouna *et al.*, (2010), and a number of previous studies which found education to be significant.

### Conclusion and Recommendations

In the current study, smallholder maize production is affected by farmer's age - a proxy for experience that provides benefits of hindsight in decision making. This calls for acknowledging farmers experience when formulating strategies for improving maize production.

Resource base as captured by size of cattle herd and cropped area are critical drivers of maize production in Migori County. It is therefore important to empower farmers' resource wise to improve their chances of increasing maize production. This could be done by creating both off-farm and on-farm income generating opportunities that would improve their purchasing power to facilitate access to production inputs. In addition, maize production faces stiff competition from tobacco farming which is also detrimental to the environment, health of farmers and seems to keep majority of farmers in a perpetual cycle of poverty. Measures should therefore be taken to improve the beneficial effect of tobacco on farmers while managing its deleterious effect on the environment and the farmers.

### References

- Ackello, O. C. and Echessah T. P.** (2003): *Unrecorded Cross Border Trade Between Kenya and Uganda -Implications for Food Security*: USAID Publication Series; Technical Paper No. 59.
- Buresh R.J., Sanchez P.A., and Calhoun, F.** (2005). *Replenishing soil fertility in Africa*. SSSA special publication no. 51: Madison, Wisconsin.
- Gerhart, J.** (1975). *The Diffusion of Hybrid Maize in Western Kenya*. Mexico City. International Maize and Wheat Improvement Center (CIMMYT).
- Gujarati, D. N.** (2003). *Basic Econometrics*, 4th ed. McGraw-Hill, New York.
- Hazell, P.** (2009). *The role of Agriculture in Pro-Poor growth in Sub-Saharan Africa. Agricultural Development in Sub-Saharan Africa*; 8–9 March 2006, Frösundavik, Sweden Workshop Proceedings.
- Hoang V. M. et al.** (2011). *Tobacco farming in rural Vietnam: questionable economic gain but evident health risks* BMC Public Health 2009, 9:24doi:10.1186/1471-2458-9-24.
- Karanja, D. D. and Oketch, A. G. O.** (1992). *The Impact of Maize Research in Kenya. in Proceedings of a Workshop. Review of the National Maize Research Program. KARI/ISNAR. Management Training Linkage Project*. 100.
- Khairo, S. A. and Battese, G. E.** (2005). "A Study of Technical Inefficiencies of Maize Farmers within and Outside the New Agricultural Extension Program in the Harari Region of Ethiopia." South African Journal of Agricultural Extension, 34.
- Kodhek, G. A.** (2003). *Feast and Famine: Financial Services for Rural Kenya*, Working Paper, Tegemeo Institute.
- Mantel, S. and Engelen, V. W. P.** (1994). The impact of land degradation on food productivity. Case studies of Uruguay, Argentina and Kenya, Volume 1, Volume 1: main report.
- Mignouna, D. B., Mutabakazi, K., Senkondo, E. M., and Manyong, V. M.** (2010). Adoption of a New Maize Variety and Production Efficiency in Western Kenya. Contributed Paper Presented at the Joint 3<sup>rd</sup> African Association of Agricultural Economists (AAAE) and 48<sup>th</sup> Agricultural Economists Association of south Africa (AEASA) Conference, Cape Town, South Africa, September 19-23, 2010.
- Olwande, J.** (2012). Smallholder Maize Production Efficiency in Kenya. Tegemeo Institute of Agricultural Policy and Development.

**Yanikkaya, H.** (2004). Import Demand for the United States: A Translog Cost

Function Analysis. *Akdeniz I.I. B.F. Dergisi (7) (2004):* 145-155.

# **Analysis of the Obama Victory Speech and Lessons to Makers of Political Diatribe**

By

**Benard Odoyo Okal<sup>1\*</sup>**

*1; Department of Kiswahili and Other African Languages, Maseno University, Maseno, Kenya  
Corresponding author: [benardodoyo@yahoo.com](mailto:benardodoyo@yahoo.com)*

---

## **Abstract**

The paper focuses on the analysis of some selected aspects of discourse analysis as a discipline with regards to the famous Barack Obama Victory Speech posted on 4<sup>th</sup> November, 2008. This speech is an eye opener not only to the political intelligentsia in Kenya but also to the general citizenry. The aspects of discourse analysis under discussion include among others the cohesive devices, deictic markers, speech event theory, speech act theory and the Gricean Cooperative principle. The paper looks at how the Obama Victory Speech embraced these aspects of discourse analysis and probably the lessons that can be learnt by the makers of political diatribe in Kenya in an attempt to enhance peaceful coexistence among different ethnic groups now and posterity.

**Key words:** cohesive devices, deictic, speech event, speech act, cooperative principle.

---

## **Introduction**

The paper gives a critical analysis of selected aspects of discourse analysis in the Barack Obama Victory Speech posted on the 4<sup>th</sup> day of November, 2008 that he made at a rally in Grant Park in Chicago, Illinois, immediately after winning the race for the White House and its probable lessons that can be learned by the makers of political diatribe in Kenya. This is because Kenya's political speeches seem to be coated with props like in cinematography. In an attempt to accomplish this noble task, the paper is divided into various sections. Section 1.1.1 deals with the definition of discourse analysis, what it entails, its brief history and its future and section 1.1.2 gives a preamble to the concept of speech, its types, situations of speech, speech context, the motivated sequence sample outline of speech and the

characteristic traits of a good speech. Section 1.2 shows a transcript of Barack Obama Victory Speech posted on the 4<sup>th</sup> day of November, 2008 that will be a text for analysis in this paper. Section 1.3 is concerned with the critical analysis of selected aspects of discourse analysis in regards to Barack Obama Victory Speech such as cohesive devices, deictic markers, speech event theory, speech act theory and the Gricean cooperative principle. Section 1.4 gives the lessons that can be learned from the Obama victory speech in regards to political processes in Kenya both to the political elite and the ordinary citizens and the last section provides a conclusion to the article.



### *Discourse analysis*

Discourse analysis is a discipline that generally discusses various forms of discourses. The term discourse is sometimes referred to as 'language use or language in use' or 'a discrete subset of a whole language, used for a specific social or institutional purposes' (Asher, 1994). However, discourse can be formally defined as 'a long and serious treatment or discussion of a subject in speech or writing' (Hornby, 2010). Though from the above definitions discourse is treated as along and serious discussion of a subject, there are other discourses that are shorter but complete in meaning like the menus in hotels and even names of places as studied in the discipline generally referred to as onomastics. Therefore, discourse may include among others debates, propaganda, notices, reports, menus, directives, recipe, road signs, speeches, sermons, lectures, conversations, letters and minutes. This paper does not analyse all these examples but zeros in only on the aspect of speech.

The term discourse is instrumentally used in the linguistic field as a discipline famously known as discourse analysis that refers to 'the use of language in speech and writing in order to produce meaning; language that is studied, usually in order to produce meaning; language that is studied, usually in order to see how the different parts of a text are connected' (Hornby, 2010). Effective discourse analysis relies on both the discourse competence that refers to the ability to use language in real contexts and communicative competence that refers to the ability to generally communicate in a language (Hubbard, 2000).

Discourse analysis has a recent history. According to Fairclough (1992), the history of discourse analysis as a discipline could be traced back to the seventies. For example, Sinclair and Coulthard (1975) analysed the classroom conversation. Later the works of Labov and Fanshel in 1977 concerning discourses in the clinical milieu were also witnessed (Fairclough, 1992). Currently,

the discipline has picked momentum as a very instrumental course and is regarded as a fully fledged course studied at various learning institutions. Discourse analysis course is important in the analysis of types of audiences, sequencing in turn taking, composition of conversation and even ways of communication in different contexts among others (Wray, Trott, Bloomer, Reay and Butler, 1998). In the many sections of this work, various aspects of discourse analysis as a discipline with special reference to Barack Obama Victory Speech of 4<sup>th</sup> November, 2008 are discussed.

### *The concept of speech and its requisite components*

This section deals with the definition of speech, analysis of motivated sequence sample outline of speech and also a glimpse of what constitutes a good speech. Speech is 'a formal talk that a person gives to an audience' (Hornby, 2010). This formal talk is given to audience at various important functions. Generally, speech can either be spoken or written. In this regard, speech can therefore be referred to also as utterance that can either be in spoken or written form. It is evident that a spoken speech manifests various paralinguistic devices of the speaker that subsequently stir up emotions of audiences. However, even in the written speeches, emotions can be evoked in the minds of audience depending on the stylistic devices applied by the author in order to manifest the same perlocutionary force as the spoken utterances.

Perlocutionary force simply refers to effects of both the spoken and written texts on the receivers or the audience or the extent to which the receiver's state of mind or knowledge or attitude is altered by the utterance in question (van Dijk, 1977; de Beaugrande and Dressler, 1981; Hatim and Mason, 1990). In many instances, we see demonstrations of persons more charged than before especially when they have received a charged speech. That behaviour witnessed as a result of the dispensed speech

is what is referred to as the perlocutionary effect.

Any given speech has situations that are of course very instrumental for any serious work. Leech (1983) orders these situations of speech as addressers and addressees, context of utterance or speech, goals of utterance, activity of the utterance and the product of the verbal act which can be a demonstration and even boycott of work among others. The addresser generally refers to the speaker or the author of a discourse while the addressees refer to the audience or the receiver of the discourse. Context of the speech is concerned with the background knowledge assumed to be shared by both the speaker and the audience and also the nature of event in which the speech is dispensed that can be political, social or economic. Goals are the intentions of the speaker. The activity of the utterance means various acts performed during the period of speech dispensation and lastly the product of the verbal act that refers to the meaning of the speech.

However, Lyons (1981) cautions that meaning of an utterance or rather speech generally tends to fall outside the province of linguistic semantics since one cannot give its full account of meaning without relating to the actual context. Thus, an utterance is generally studied in a discipline called pragmatics that simply refers to how utterances have meanings in situations (Leech, 1983) or the aspects of meaning from language use in context and situations, with particular reference to assumptions and inferences made by participants and the purposes for references involved (Channell, 1994). Though, utterance is basically studied in pragmatics, the linguistic aspects must be involved in order to yield both the coherence and cohesion of the text.

Any speech may adhere to the following five motivated sequence steps that are generally renamed as the Monroe's Motivated Sequence Sample Outline that concerns the

persuasive speech (<http://people.yosu.edu/~fowens/MotivatedSequenceSample.pdf>).

These steps include: attention, need, satisfaction, visualization and action. The attention step introduces the audience to the background information to the speech topic that should be captivating and factual. The need step therefore exhibits the problem to be discussed in the speech. This is sometimes referred to as the statement of the problem. The satisfaction step draws conclusion about the problem if indeed it has to be addressed urgently or postponed. The visualization step involves giving somewhat an emotional touch to the topic and creating a picture of what is talked about in the minds of the audience by repeating the conclusion about the statement of the problem. The action step of the speech involves what the writer or the speaker intends to do in order to avert or redress the situation of the topic in discussion.

It is normally the utmost happiness of any writer and the audience to draft and receive a good speech that can be appreciated by all citizens. However, the composition of a good speech tends to be both subjective and objective. Other scholars urge that a good speech has various considerations that must be put in place. According to Horton (2005), a good speech should be one that moves an audience especially where a speaker wants it to go. In this aspect, style may not matter but the results of the speech will be of a profound value. These results are the so called the perlocutionary force which we had talked about earlier.

Horton (2005) talks of the following factors that constitute a good speech: there should be persuasion of the audience by including a logical approach and also involving moral component and truth. The speech writer should consider the effect of speech on the audience. The speech should be efficient communication whereby an end is achieved with minimum energy. The speech can be long to involve step by step persuasion of the audience, short but motivating, emotional or

even a mixture of logic and emotions in order to involve constant participation between the speaker and the audience. A short speech should entail an exposition of an idea, defend it and motivate the audience faster.

The speech should have a content that involves both the speaker and the audience. In this regard, the speaker has to understand the audience especially who they are, what they think, their backgrounds and cultures, why they may listen to the speech and how to reach them effectively. During the verbal dispensation of the speech, the speaker should be communicating through expressions, body movements and confidence. In fact, a speech writer must always study the speaker's mannerisms. In a nutshell, the following excerpt summarises a good speech as quoted from Horton (2005):

'Good speeches are never written in vacuums. They fit a place, time, a speaker and audience. Few speeches or speakers ever rise above audiences they persuade at a given moment in time. Speechwriting, therefore, is mostly a practical craft and not one of poetry or expression. Only a few speakers are remembered from any generation for their ability to rise above place and time and to speak across them both. Rarely are CEOs ever called upon to do that'.

In my personal opinion, the Barack Obama Victory Speech in this discussion tends to fulfill the composition of a good speech as explained by Horton (2005).

### **The transcript of Barack Obama victory speech**

In the year 2008, the president elect Barack Obama of the United States of America made a very good, timely, promising and in fact peace-laden speech that was and still is a motivating factor to many politicians and persons with passion for change in their various nations, states and countries. Barack Obama became the 44<sup>th</sup> president of the United States. Here below is his speech

transcript that was made after winning the race for the White House on Tuesday night 4<sup>th</sup> November, 2008 at a rally in Grant Park in Chicago, Illinois. This speech will serve as a text for our discussion in this paper. The paragraphs are numbered from 1 to 59 for easy reference and letter [P] is used as an abbreviation:

### **Barack Obama Victory Speech Transcript**

Posted on November 4, 2008 by JoeDuck

Hello, Chicago.

If there is anyone out there who still doubts that America is a place where all things are possible, who still wonders if the dream of our founders is alive in our time, who still questions the power of our democracy, tonight is your answer.

It's the answer told by lines that stretched around schools and churches in numbers this nation has never seen, by people who waited three hours and four hours, many for the first time in their lives, because they believed that this time must be different, that their voices could be that difference.

It's the answer spoken by young and old, rich and poor, Democrat and Republican, black, white, Hispanic, Asian, Native American, gay, straight, disabled and not disabled. Americans who sent a message to the world that we have never been just a collection of individuals or a collection of red states and blue states.

We are, and always will be, the United States of America.

It's the answer that led those who've been told for so long by so many to be cynical and fearful and doubtful about what we can achieve to put their hands on the arc of history and bend it once more toward the hope of a better day.

It's been a long time coming, but tonight, because of what we did on this date in this election at this defining moment change has come to America.

A little bit earlier this evening, I received an extraordinarily gracious call from Sen. McCain.

Sen. McCain fought long and hard in this campaign. And he's fought even longer and harder for the country that he loves. He has endured sacrifices for America that most of us cannot begin to imagine. We are better off for the service rendered by this brave and selfless leader.

I congratulate him; I congratulate Gov. Palin for all that they've achieved. And I look forward to working with them to renew this nation's promise in the months ahead.

I want to thank my partner in this journey, a man who campaigned from his heart, and spoke for the men and women he grew up with on the streets of Scranton and rode with on the train home to Delaware, the vice president-elect of the United States, Joe Biden.

And I would not be standing here tonight without the unyielding support of my best friend for the last 16 years the rock of our family, the love of my life, the nation's next first lady Michelle Obama.

Sasha and Malia I love you both more than you can imagine. And you have earned the new puppy that's coming with us to the new White House.

And while she's no longer with us, I know my grandmother's watching, along with the family that made me who I am. I miss them tonight. I know that my debt to them is beyond measure.

To my sister Maya, my sister Alma, all my other brothers and sisters, thank you so much for all the support that you've given me. I am grateful to them.

And to my campaign manager, David Plouffe, the unsung hero of this campaign, who built the best - the best political campaign, I think, in the history of the United States of America.

To my chief strategist David Axelrod who's been a partner with me every step of the way.

To the best campaign team ever assembled in the history of politics you made this happen, and I am forever grateful for what you've sacrificed to get it done.

But above all, I will never forget who this victory truly belongs to. It belongs to you. It belongs to you.

I was never the likeliest candidate for this office. We didn't start with much money or many endorsements. Our campaign was not hatched in the halls of Washington. It began in the backyards of Des Moines and the living rooms of Concord and the front porches of Charleston. It was built by working men and women who dug into what little savings they had to give \$5 and \$10 and \$20 to the cause.

It grew strength from the young people who rejected the myth of their generation's apathy who left their homes and their families for jobs that offered little pay and less sleep.

It drew strength from the not-so-young people who braved the bitter cold and scorching heat to knock on doors of perfect strangers, and from the millions of Americans who volunteered and organized and proved that more than two centuries later a government of the people, by the people, and for the people has not perished from the Earth.

This is your victory.

And I know you didn't do this just to win an election. And I know you didn't do it for me. You did it because you understand the enormity of the task that lies ahead. For even as we celebrate tonight, we know the challenges that tomorrow will bring are the greatest of our lifetime - two wars, a planet in peril, the worst financial crisis in a century.

Even as we stand here tonight, we know there are brave Americans waking up in the deserts of Iraq and the mountains of Afghanistan to risk their lives for us.

There are mothers and fathers who will lie awake after the children fall asleep and wonder how they'll make the mortgage or pay their doctors' bills or save enough for their child's college education.

There's new energy to harness, new jobs to be created, new schools to build, and threats to meet, alliances to repair.

The road ahead will be long. Our climb will be steep. We may not get there in one year

or even in one term. But, America, I have never been more hopeful than I am tonight that we will get there.

I promise you, we as a people will get there. There will be setbacks and false starts. There are many who won't agree with every decision or policy I make as president. And we know the government can't solve every problem.

But I will always be honest with you about the challenges we face. I will listen to you, especially when we disagree. And, above all, I will ask you to join in the work of remaking this nation, the only way it's been done in America for 221 years — block by block, brick by brick, calloused hand by calloused hand.

What began 21 months ago in the depths of winter cannot end on this autumn night.

This victory alone is not the change we seek. It is only the chance for us to make that change. And that cannot happen if we go back to the way things were.

It can't happen without you, without a new spirit of service, a new spirit of sacrifice.

So let us summon a new spirit of patriotism, of responsibility, where each of us resolves to pitch in and work harder and look after not only ourselves but each other.

Let us remember that, if this financial crisis taught us anything, it's that we cannot have a thriving Wall Street while Main Street suffers.

In this country, we rise or fall as one nation, as one people. Let's resist the temptation to fall back on the same partisanship and pettiness and immaturity that have poisoned our politics for so long.

Let's remember that it was a man from this state who first carried the banner of the Republican Party to the White House, a party founded on the values of self-reliance and individual liberty and national unity.

Those are values that we all share. And while the Democratic Party has won a great victory tonight, we do so with a measure of humility and determination to heal the divides that have held back our progress.

As Lincoln said to a nation far more divided than ours, we are not enemies but friends.

Though passion may have strained, it must not break our bonds of affection.

And to those Americans whose support I have yet to earn, I may not have won your vote tonight, but I hear your voices. I need your help. And I will be your president, too.

And to all those watching tonight from beyond our shores, from parliaments and palaces, to those who are huddled around radios in the forgotten corners of the world, our stories are singular, but our destiny is shared, and a new dawn of American leadership is at hand.

To those — to those who would tear the world down: We will defeat you. To those who seek peace and security: We support you. And to all those who have wondered if America's beacon still burns as bright: Tonight we proved once more that the true strength of our nation comes not from the might of our arms or the scale of our wealth, but from the enduring power of our ideals: democracy, liberty, opportunity and unyielding hope.

That's the true genius of America: that America can change. Our union can be perfected. What we've already achieved gives us hope for what we can and must achieve tomorrow.

This election had many firsts and many stories that will be told for generations. But one that's on my mind tonight's about a woman who cast her ballot in Atlanta. She's a lot like the millions of others who stood in line to make their voice heard in this election except for one thing: Ann Nixon Cooper is 106 years old.

She was born just a generation past slavery; a time when there were no cars on the road or planes in the sky; when someone like her couldn't vote for two reasons — because she was a woman and because of the color of her skin.

And tonight, I think about all that she's seen throughout her century in America — the heartache and the hope; the struggle and the progress; the times we were told that we can't, and the people who pressed on with that American creed: Yes we can.

At a time when women's voices were silenced and their hopes dismissed, she lived

to see them stand up and speak out and reach for the ballot. Yes we can.

When there was despair in the dust bowl and depression across the land, she saw a nation conquer fear itself with a New Deal, new jobs, a new sense of common purpose. Yes we can.

When the bombs fell on our harbor and tyranny threatened the world, she was there to witness a generation rise to greatness and a democracy was saved. Yes we can.

She was there for the buses in Montgomery, the hoses in Birmingham, a bridge in Selma, and a preacher from Atlanta who told a people that "We Shall Overcome." Yes we can.

A man touched down on the moon, a wall came down in Berlin, and a world was connected by our own science and imagination.

And this year, in this election, she touched her finger to a screen, and cast her vote, because after 106 years in America, through the best of times and the darkest of hours, she knows how America can change. Yes we can.

America, we have come so far. We have seen so much. But there is so much more to do. So tonight, let us ask ourselves — if our children should live to see the next century; if my daughters should be so lucky to live as long as Ann Nixon Cooper, what change will they see? What progress will we have made?

This is our chance to answer that call. This is our moment.

This is our time, to put our people back to work and open doors of opportunity for our kids; to restore prosperity and promote the cause of peace; to reclaim the American dream and reaffirm that fundamental truth, that, out of many, we are one; that while we breathe, we hope. And where we are met with cynicism and doubts and those who tell us that we can't, we will respond with that timeless creed that sums up the spirit of a people: Yes, we can.

Thank you. God bless you. And may God bless the United States.

(Source: Duck (2008) Barack Obama Victory Speech Transcript. US President Elect

Speech. November 4th 2008  
<http://joeduck.com/2008/11/04/barack-obama-victory-speech-transcript-us-president-elect-speech-november-4th-2008>)

### **Aspects of discourse analysis in the Obama Speech**

Under this section, I discuss some selected aspects of discourse analysis by critically analysing how they are manifested in the Obama Victory Speech posted on 4<sup>th</sup> November, 2008. These aspects include: cohesive devices, deictic markers, speech event theory, speech act theory and cooperative principle.

#### *Cohesive devices*

Just like any neatly knitted cloth that needs expertise sewing from the dresser and style so as to produce a good work, the speech or any utterance be it spoken or written needs also not only cohesive devices but also coherence. Before discussing cohesive devices that is the core of our discussion in this section, let me draw your attention to the concept of coherence which is another aspect of discourse analysis that relates with cohesion then later discuss cohesive devices independently.

Many scholars view coherence by using various terminologies. For example, it refers to relations that is holding between propositions that are always expressed by composite sentences and sequences of sentences (van Dijk, 1977), quality of meaning, unity and purpose that are normally perceived in discourse (Cook, 1989) or simply a text that sticks together (Hatch, 1992). In other words, coherence can simply be referred to as a logical sequence of relations, organization of events, objects and situations and continuity of human experience (Hatim and Mason, 1990). Coherence can be vividly witnessed in the following excerpts:

(A)

My father once bought a Lincoln convertible. He did it by saving every penny

he could. That car would be worth a fortune nowadays. However, he sold it to help pay for college education. Sometimes, I think I'd rather have the convertible (Yule, 1996).

(B)

My father bought a Lincoln convertible. The car driven by the police was red. That color doesn't suit her. She consists of three letters. However, a letter isn't as fast as a telephone call (Yule, 1996).

From the two texts (A) and (B), it is evident that text (A) has coherence in that the events are logically arranged so as to make sense especially drawing our attention to the writer's father who bought a Lincoln convertible by saving every penny. He goes further to explain the worthiness of this car and even why he sold it. In fact, all the events are logically arranged. However, text (B) lacks coherence in that the writer is talking of his father who bought a Lincoln convertible then reverts to talking about another person, the police in a red car. There is also another talk about a female and her unsuitable colour, talking of letters and the telephone call.

Indeed coherence is always regarded as an aspect in discourse analysis that plays the role of adhering to semantic notion underlying text and also a mental principle in order to achieve comprehension (Blass, 1990). This means that, whenever we write any given text the logical ordering from introduction to the conclusion results into what is referred to as coherence. It is an obligation of any speech writer to ensure that the speech that is intended to exude emotional appeal and recognizable perlocutionary effect adheres to the aspect of coherence. The Barack Obama speech in this article has a high degree of coherence flowing right from the introductory section to the conclusion.

On the other hand cohesion refers to sequential connectivity of surface elements that are generally sentences and the lexis in a text (Hatim and Mason, 1990). It simply

means the use of other words in an utterance to show connectivity so as to avoid ambiguity. Cohesion occurs when the interpretation of some elements in the discourse in question depend on the others (Hubbard, 2000). These surface elements of a text are sometimes referred to as the cohesive devices and are normally classified into two major forms namely grammatical and lexical categories (Halliday and Hasan, 1976; Halliday, 1985). Grammatical forms of cohesion include: reference, substitution, ellipsis and also conjunctions.

Reference can be either anaphoric or cataphoric (Halliday and Hasan, 1976; Hatch, 1992). Anaphoric relation of words in a text gives relations backwards by referring to what had been mentioned earlier. For instance, [Look at that child. She is really dancing]. From this example, the word [she] shows an anaphoric relation that refers backwards to the word [child]. On the other hand cataphoric relation refers to forward relation of what will be mentioned later. For instance, [It is going to be competitive, the Kenya's general elections]. In this sentence, the word [It] gives a cataphoric relation of what is going to be competitive that is of course [Kenya's general elections]. Hubbard (2000) categorises reference in other ways such as the: personal pronouns [I, me, we, us, he, she and they], possessive pronouns [my, our, you, his, hers, its and their], definite article and determiners [the, this, these, that and those] and also demonstrative adverbs [here, there and then].

Substitution refers to the use of another word to substitute the other of the same sense or meaning like substituting the word *askari* with *security guard* in two different sentences. Sometimes the word can be substituted not with a synonym but with another word of a different category for example in the sentence [Jane has a *birthday* tomorrow]. The word *birthday* can be substituted as in the sentence [Doreen has *one* too next week] whereby *birthday* is substituted with the word *one*.

On the other hand ellipsis refers to removing of a word totally from a text without the negative influence of the meaning like in the sentence [President Kibaki of Kenya made a good speech] can be rewritten as [President of Kenya made a good speech] by deleting the word [Kibaki]. The first and the second sentence still have the same connotation.

There are also conjunctions that are used in connecting words and sentences in a text. Conjunctions include additive such as [and, furthermore, thus, or, in addition, similarly], adversative like [but, though, even though, conversely, on the other hand, nevertheless], causative or causal for example [so, therefore, consequently, for this reason, from this] and temporal conjunctions like [then, after that, an hour later, later, earlier, future, finally, at last].

Lexical forms in a text may include synonyms, super ordinates or hypernyms, antonyms and also collocations. Lexical forms may also involve literary devices like rhetoric, euphemisms and even personification.

The Barack Obama Victory Speech shows usage of many examples of cohesive devices. Anaphoric relation includes [he] that refers backwards to [Se. McCain] as witnessed in the following P9:

[Sen. McCain fought long and hard in this campaign. And he's fought even longer and harder for the country that he loves. He has endured sacrifices for America that most of us cannot begin to imagine...]

The word [them] in the following paragraphs is used to show anaphoric reference to both [Sen. McCain] in P9 and also [Gov. Palin] in P10:

[I congratulate him; I congratulate Gov. Palin for all that they've achieved. And I look forward to working with them ...]

The word [It] shows an anaphoric relation to [Our campaign] in P20 as can be seen here below:

[I was never the likeliest candidate for this office. We didn't start with much money or many endorsements. Our campaign was not hatched in the halls of Washington. It began in the backyards of Des Moines and the living rooms of Concord and the front porches of Charleston. It was built by working men and women who dug...]

Anaphoric relation is seen also in P39 the word [party] refers back to [Republican] as here below indicated:

[...the banner of the Republican Party to the White House, a party founded on the values of self-reliance and individual liberty and national unity]

There is also the use of the word [she] in P47 and P48 that shows anaphoric relation to [Ann Nixon Cooper] in P46.

On the other hand, cataphoric relation is also witnessed in this speech for example [we] is used contextually to refer forward to [the United States of America] in P5:

[We are, and always will be, the United States of America]

Paragraph 11 shows the use of [my partner] referring to cataphoric relation to [Joe Biden] as can be seen in the following excerpt:

[I want to thank my partner in this journey, a man who campaigned from his heart, and spoke for the men and women he grew up with on the streets..., the vice president-elect of the United States, Joe Biden]

In P14 the word [she] is a cataphoric relation to [grandmother] and [them] referring to both [grandmother] and [family] as in the following excerpt:

[And while she's no longer with us, I know my grandmother's watching, along with the family that made me who I am. I miss them tonight. I know that my debt to them is beyond measure]

Likewise an example like [my campaign manager] shows a cataphoric relation to [David Plouffe] in P16 and [my chief strategist] refers to [David Axelrod] in P17:

[And to my campaign manager, David Plouffe, the unsung hero of this campaign,



who built the best — the best political campaign, I think, in the history of the United States of America]

[To my chief strategist David Axelrod who's been a partner with me every step of the way]

Substitution is witnessed for instance in P20 where the word [our campaign] is substituted with [It] and also [the cause] as can be witnessed here below:

[...Our campaign was not hatched in the halls of Washington. It began in the backyards of Des Moines and the living rooms of Concord and the front porches of Charleston. It was built by working men and women who dug into what little savings they had to give \$5 and \$10 and \$20 to the cause]

There is use of substitution in P57 whereby [our chance] is substituted with [our moment] as witnessed in the excerpt below:

[This is our chance to answer that call. This is our moment]

Ellipsis that involves deletion of sections of the sentence but does not impact negatively on the meanings intended is also used in this speech. For instance, there is a mention of [United States of America] in P5 which in other sections is just referred to as [United States] in P11 and [America] as in the case with P45.

Some conjunctions used in connecting words and sentences in a text in this work include among others the following categories: additive, adversative, causative and temporal. Additive conjunction includes examples such as [and, or] in P3, P4, P5, P6 and P11 among others. See an example from P4:

[It's the answer spoken by young and old, rich and poor, Democrat and Republican, black, white, Hispanic, Asian, Native American, gay, straight, disabled and not disabled. Americans who sent a message to the world that we have never been just a collection of individuals or a collection of red states and blue states]

The adversative conjunction like [but] can be seen in P7 and P19:

[It's been a long time coming, but tonight, because of what we did on this date in this election at this defining moment change has come to America]

[But above all, I will never forget who this victory truly belongs to. It belongs to you. It belongs to you]

The causative or causal conjunction is witnessed in P7 for example the word [because]:

[...because of what we did on this date in this election at this defining moment change has come to America]

Likewise P47 also shows the use of a causative conjunction [because]:

[She was born just a generation past slavery; a time when there were no cars on the road or planes in the sky; when someone like her couldn't vote for two reasons — because she was a woman and because of the color of her skin]

The temporal conjunctions like [earlier] has been used in P8:

[A little bit earlier this evening, I received an extraordinarily gracious call from Sen. McCain]

The lexical forms in this text include contextual super ordinates that mean general words which include specific ones for example [challenges] in P25 includes [two wars, a planet in peril and the worst financial crisis in a century]. There is also an example in P44 [...our ideals] include [democracy, liberty, opportunity and unyielding hope]. Antonyms that refer to words with contrasting meanings are also witnessed for example in P4 we have [young and old, rich and poor, Democrat and Republican and also disabled and not disabled], there is also [winter and autumn] in P33.

Repetition of words that is normally used to attract attention of audience is manifold in this text. For example the word [I] is repeated in P10, P 14, P32 and P42 among

others. In P19, there is [...belongs to you], [...And I know...] in P24, [block by block, brick by brick, calloused hand by calloused hand] in P32, [...a new spirit...] in P35, [...as one...] in P38, [to those...] repeated in P44 and the famous America's creed [Yes we can] in P48, P49, P50, P51, P52, P55 and P58.

Lexical forms can also involve literary devices like rhetoric and personification. The speech manifests the use of personification whereby America is regarded as being a live as in P56:

[America, we have come so far...]

Rhetorical utterances which refer to questions that are just asked to make statements rather than getting answers are also witnessed in this speech for example P56:

[So tonight, let us ask ourselves — if our children should live to see the next century; if my daughters should be so lucky to live as long as Ann Nixon Cooper, what change will they see? What progress will we have made?]

### *Deictic markers*

There are very important words in a text that are linguistically referred to as deictic markers. Deictic markers are sometimes referred to as deixis that means 'the function or use of deictic words or expressions' Hornby (2010). The term deictic emanates from Greek word 'deixis' which means pointing (Hatch, 1992). Therefore in linguistic studies it simply means identifying by pointing and is used to refer to ourselves, others and even to objects (Hatch, 1992). This article has used both deictic and deixis interchangeably. According to Levinson (1983) as cited by Hatch (1992), there are various types of deictic markers which are categorised as person, place or spatial, temporal, discourse and social.

Person deixis means the grammatical marker of participant's role in a speech event and is normally concerned with words like [I, you, us]. Place or spatial deixis refers to

relationship between space and the location of participants in text. These relationships can show closeness or proximal and distal that could be far away from the speaker. In simpler terms, these are referred to as demonstratives like [in front, in back, a head, at our place, in the west, out west]. Temporal deixis refers to time in relation to the speaker for instance [now, then, yesterday, today, tomorrow, next week]. Discourse deixis is concerned with keeping track of reference in the unfolding discourse for example [in the next chapter, in the following sections].

Social deixis is concerned with the codes of social relations between the speaker and the audience. The social deixis includes two major types: the relational and absolute. Hatch (1992) says that relational deixis includes honorific that is used to show respect to the person you are referring to, titles of address and even pronouns among others. Other simple examples of social relational deixis are [my wife, my husband, my cousin, grandmother and the teacher]. Absolute deixis relates the speaker with the roles of the person in the society like [The Right Honourable Prime Minister, His Excellency the President, The Right Reverend, Professor so and so].

The Barack Obama Victory Speech has these deictic markers making this speech very stimulating and motivating. Person deixis are clearly used in this speech for instance [we are...] in P5, [I...], in P8, [I congratulate him; I congratulate Gov. Palin...And I look forward...] in P10, [And I would not...] in P12, [I know my grandmother's ...I miss them tonight] in P14, and also [To my sister Maya...] in P15.

Place or spatial deixis are normally regarded sometimes as demonstratives but sometimes concrete names of places are named straightaway. In this speech, place or spatial deixis are manifested in [...get there] in P30, [Delaware] in P11, [Washington... des Moines ... Concord and front porches of Charleston] in P20, [the Earth] in P22,

[Atlanta] in P46 and also [Montgomery... and also Birmingham] in P52.

Temporal deixis in the text include [...tonight] in P7, [...earlier this evening...] in P8 and also [...winter...autumn night] in P33. Discourse deixis which are sometimes considered as connectors include [when there was...] in P50 and also [when the bombs fell...] in P51. In regards to social deixis, there is use of relational deixis like [...rock of our family...nation's next first lady Michelle Obama] in P12, [my grandmother's...] in P14, [my sister Maya, my sister Alma...brothers and sisters...] in P15. There are also absolute social deixis that refer to the roles of individuals in the society for example [...Sen. McCain] in P8, [...Gov. Palin...] in P10, [...campaign manager...] in P16 and also [...chief strategist...] in P17.

### ***Speech event theory***

Speech event theory simply refers to activities governed by norms for the effective completion of speech (Hubbard, 2000). The theory was propounded by Dell Hymes in 1972 when he generally identified the following nine activities of a speech event: setting, participants, ends or goals, acts or activities, key, instrumentality, norms, genre and topic (Brown and Yule, 1983; Hatch, 1992; Hubbard, 2000). Setting refers to time and physical place of the event like the church, parliament and even special meetings. Participants include the speakers in the speech event together with the audience. The ends or goals refer to the aims of the speech in a speech event. There are also acts or activities involved in the speech event.

The aspect of key refers to the register used and is basically concerned with the tone, manner and the spirit of the speech event. Instrumentality refers to the channel or the medium of passing the speech which can be in writing or speaking. The norms mean the behaviour that accompanies the speech like turn taking, raising voice and even interruptions during speech making. Genre

of the speech may involve the use of riddles, poems and even songs when giving either spoken or written speeches. The element of topic is generally the title of the speech.

In reference to the Barack Obama Victory Speech, it is evidently clear that when he was giving his speech, the speech seemingly embraced all the nine aspects of the speech event theory. The setting in this speech is political and includes the period after democratic elections in which he emerged the winner. The physical place in which the speech is given is the Grant Park in Chicago, Illinois, in the United States. The participants refer to the speakers in the speech event together with the audience. In the speech, the speaker is Barack Obama himself addressing the Chicago residents especially when he begins his speech with [Hello, Chicago] in P1 and to all the people of America whom he inclusively refer to as [young and old, rich and poor, Democrat and Republican, black, white, Hispanic, Asian, Native American, gay, straight, disabled and not disabled] in P4.

The main ends or goals of this speech are to portray America as a place where all things are possible and also giving hopes to the Americans in P2. Furthermore, the speaker concludes that America will always be United States of America in P5. It is my belief that by portraying America as a place where all things are possible generally creates a positive perlocutionary effect on his audience who in return will work hard and forever embrace peace in the United States. Acts or activities involved during this speech can be predicted as praising the speaker, clapping of hands and even receiving of an immediate feedback from the audience. For instance, the opening statement that is [Hello, Chicago] in P1 of course must have been responded to by the Chicagoans also as [Hello]. This was a talking speech which as can be witnessed in the video shows happiness on the faces of the audience, clapping of hands and other uses of paralinguistic devices.

The aspect of key that refers to the register used is of course political in nature. The instrumentality of this speech refers to the channel and the medium of passing the speech which was basically a spoken text before the charming audience. Norms that involve behaviour that accompanies the speech like loud voice and repetition of words are witnessed in many paragraphs of this speech.

In regards to the Obama speech, we can see the use of genre especially literary devices such as personification in which the women voices that were silenced can now stand up and speak out in P49 and repetition in many paragraphs. He is also referring to America as a living being for example [America, we have come so far. We have seen so much] in P56. The speaker also uses analogies and stories of a woman named [Ann Nixon Cooper] in Atlanta in P46 and also remembering [Wall Street] in P37, [...a man who carried the banner of the Republican Party to White House] in P39 and also [...Lincoln...] in P41.

The topic that is generally the title of the speech is clearly indicated. It reads as [Barack Obama Victory Speech]. The speech captures who the speaker is and its core topic that is basically victory. The title also has the day, month and the year and the designation already attached to the speaker as [US President Elect Speech]. In fact, such a title captures the curiosity of listeners and observers alike so as to make judgements on what the Barack Obama leadership may embody.

### *Speech act theory*

There is always an old adage that 'actions speak louder than words'. However, the words that we normally utter tend to have some performative verbs or action verbs. This means that there is an act of assertion carried out when speaker utters a sentence (Hurford and Heasley, 1983). From these actions of words, the speech act theory came into existence. Speech act theory was

propounded by J. Austin in 1962 when he talked of the ability of sentences to perform actions and later the theory was refined by Searle in 1969 and 1976 (Hatim and Mason, 1990). The speech act theory that involves the actions of utterance of a text relies on the following acts as defined by various scholars. For example, van Dijk (1977) and even de Beaugrande and Dressler (1981) refer to these acts in four forms such as: utterance act of words and sentences, propositional acts of content and reference, illocutionary act of activities of acts involved and also the perlocutionary act referring to the effects of utterance on the audience. However, Hatim and Mason (1990) have generally reduced these acts to broadly three forms of locutionary, illocutionary and perlocutionary acts.

The illocutionary act that involves making statement with communicative force gives room to various types like representatives, expressive, verdictives, directives, commissives and declaratives (Hatim and Mason, 1990). Representatives are acts that represent a state of affair such as stating, inciting and telling among others. Expressives give expressions to the speaker's mental and emotional attitude towards a state of affair like admiring and deploring. Verdictives evaluate and relay judgement by using verbs such as assessing and estimating. Directives are meant to influence text receiver's behaviours like ordering and requesting. Commissives show commitment of the speaker to the course of action like promising, vowing and pledging. The declaratives are the ones that are performed and at the same time said by the person in authority. These declaratives are normally said and performed by adhering to the felicity conditions whereby a person in authority performs it on the other person, at appropriate time and credible audience (Hurford and Heasley, 1983).

All the speech act theory forces especially the locutionary, illocutionary and perlocutionary forces are manifested in the Barack Obama Victory Speech. The locutionary force is

witnessed in the way the speaker was very articulate in the use of selective words so as to give hopes to the people of America. Otherwise we can see how the speech embraced the aspect of illocutionary force. As had been referred to earlier in this work, illocutionary act talks of the meaning of utterances dispensed by the speaker that can be representative, expressive, verdictive, directive, commissive and declarative. All these can be judged from the way the speaker uses certain words.

Representatives show the state of affair of something for instance, Obama is telling the doubting Thomases that there is a possibility of achieving things in the United States. In P2, he tells people that those who are still wondering of the dream of their founding fathers that the time has come and tonight the answer can be witnessed.

The expressives that show the speaker's mental and emotional appeal can be witnessed by the way the speaker is expressing that [change has come to America] in P7, and in P9 and P10. Obama expresses concern by saying that he is looking forward to working with Senator McCain and even Governor Palin. The speaker is also expressing to the audience that the victory is theirs as witnessed in the statement [This is your victory] in P23. In P42 he heartily expresses concern to those who did not vote for him for example [And to those Americans whose support I have yet to earn, I may not have won your vote tonight, but I hear your voices. I need your help. And I will be your president, too].

On the other hand verdictive statements show an evaluation of and relying of judgement made by the speaker for example the speaker repeated the possibility of achieving things in America by the use of [Yes we can] that of course became a slogan and an emblem of Obama campaigns and leadership as in P48, P49, P50, P51, P52, P55 and P58. The [Yes we can] statement is a clear verdict of drawing conclusion to what the Americans can do and achieve for their

country's growth and development. There is also the use of [we shall overcome] in P52.

Directives that show an order are also manifested in this speech for instance Obama seemingly gives an order to the Americans in P36:

[So let us summon a new spirit of patriotism, of responsibility, where each of us resolves to pitch in and work harder and look after not only ourselves but each other]

Commissives show commitments of the speaker by promising, vowing and even pledging. For instance, the speaker promises to work with other dignitaries from other parties in the months to come as in P10. He also commits to work with Joe Biden as the vice president elect of the United States in P11. Though he sees the road to be long and steep, he gives a promise of reaching there as expressed in the following utterance: [I promise you, we as a people will get there] in P30. He promises to be honest, listen and ready to join hands in the remaking of the nation of the United States in P32.

Declaratives are normally performed by uttering words and at the same time performing the act. Though he himself does not perform the act in his speech, the speaker has used the God's name to bless the people of America and also the United States of America as [Thank you. God bless you. And may God bless the United States] in P59.

#### *The Gricean Cooperative principle*

Hatim and Mason (1990) opine that communication is a social obligation that relies on Co-operative principle as was enshrined in the work of Grice in 1975. The principle is normally named as Gricean Principle. The underlying assumption in this principle is that whenever we make exchanges in conversation participants are always seen to be cooperating amicably with each other (Yule, 1996). The co-operative principle includes maxims such as cooperation, quantity, quality, relation and manner (Hatim and Mason, 1990; Yule,

1996; Hubbard, 2000). The cooperation maxim refers to the continuous contribution of individuals in conversation. Quantity involves making contribution as informative as possible. Quality means saying what you believe to be true and not false. The relation maxim refers to saying what is relevant and lastly manner means a way in conversation that avoids obscurity of expressions, ambiguity, being brief and orderly.

The Barack Obama Victory Speech of 4<sup>th</sup> November, 2008 adhered to the cooperative principle by considering seemingly all its maxims of cooperation, quantity, quality, relation and manner. The speech relied on the cooperation of the audience that was basically achieved by the way he started his speech by the word [Hello]. This of course involved the audience in listening to his good speech. The word [Hello] is basically a term used for greeting and is commonly a telephone conversation terminology used in order to attract an attention of the audience (Hornby, 2010). However, Obama has used it in this speech probably to attract his audience hence building a stronger cooperation between him and the audience which is the people of United States of America.

The quantity of information in my opinion was adequate capturing the brief of how the idea of vying was mooted, campaign kitty fundraising, the pillars of his campaign and also the long journey in general. The speech is also of quantity especially in his personal agenda as the president elect and that of his political party. The speech is of high quality since it is made in such a way that the key areas to be addressed in his leadership are precisely and concisely expressed. The relevance to his speech cannot be overlooked because he tried to talk to both the Democrats and the Republicans as equal partners in the state building and to all the Americans in general thus receiving accolades from all political divides. The manner in which the speech is presented shows concerns to all the citizens of America both literate and illiterate, both scholars and

non scholars, the young and the old in that the grammar and the semantics are quite clear and easily convincing. The general structure, outline and presentation of the speech are admirable.

### **Lessons to makers of political diatribe in Kenya**

Many lessons can be learned from this speech that there is need to always have a victory speech. I believe also that even the losers should prepare their speeches so as to depict mature democracy in political circles. Every speech needs to touch and embrace both the political parties' indulgence into the development and progress of the state. There should always be enlisting of both relational and absolute deixis in order to show honour and dignity. There should always be a deal of cooperation made between the winner and the losers as was witnessed between Obama and McCain. Ways in which the party campaigns were conducted and fundraised should be indicated so as to show commitment in upholding transparency and accountability, mention the forces behind campaigns' victory, the party ideals and its way forward. Family is a very important component of any leader. This is because societies are normally formed by the peaceful amalgamation of families and any steady family of a good leader should exhibit good leadership and restoration of confidence of the voters.

Speeches that evoke perlocutionary effect on the audience are very instrumental. The Barack Obama victory speech has a very moving and promising national creed for instance: 'Yes we can'. The perlocutionary effect of a speech can be captured by using stylistic devices like repetition and rhetorical utterances among others. Speeches should never be skewed to stigmatise other tribes culturally, insulting to other opponents and their political parties, and also be simple to understand by being precise and concise. It should rather thrive to build and restore hope, stability and the desirable unity amongst its citizenry.

## Conclusion

The paper has given a critical analysis of selected aspects of discourse analysis in the Barack Obama Victory Speech posted on the 4<sup>th</sup> day of November, 2008. It is evident that any good speech fits well with a place, time, speaker and audience. All these aspects should be crafted in such a way that the speech event theory is fully accomplished. In essence, any speech should exhibit identifiable and measurable perlocutionary effects during and even after speech making. Speeches can move the audience if coherence and cohesive devices are embraced, deictic markers clearly indicated and also the consideration of speech act theory and the Gricean principle of communication.

## References

- Asher, E. R. ed.** (1994). *The encyclopedia of language and linguistics*, vol. 2. Oxford: Pergamon Press.
- Blass, R.** (1990). *Relevance relations in discourse*. Cambridge: Cambridge University Press.
- Brown, G., and Yule, G.** (1983). *Discourse analysis*. Cambridge: Cambridge University Press.
- Channell, J.** (1994). *Vague language*. Oxford: Oxford University Press.
- Cook, G.** (1989). *Discourse*. Oxford: Oxford University Press.
- de Beaugrande, R. A., and Dressler, W. U. (1981). *Introduction to text linguistics*. London: Longman.
- Duck, J.** (2008) Barack Obama victory speech transcript. US President elect speech. November 4th 2008. Accessed on 3<sup>rd</sup> August, 2012 from <http://joeduck.com/2008/11/04/barack-obama-victory-speech-transcript-us-president-elect-speech-november-4th-2008>
- Fairclough, N.** (1992). *Discourse and social change*. Cambridge: Polity Press.
- Halliday, M. A. K.** (1985). *An introduction to functional grammar*. London: Edward Arnold.
- Halliday, M. A. K., and Hasan, R.** (1976). *Cohesion in English*. London: Longman.
- Hatch, E.** (1992). *Discourse and language education*. Cambridge: Cambridge University Press.
- Hatim, B., and Mason, I.** (1990). *Discourse and the translator*. London: Longman.
- Hornby, A. S. ed.** (2010). *Oxford Advanced Learner's Dictionary of Current English*, 8<sup>th</sup> ed. Oxford: Oxford University Press.
- Horton, J. L.** (2005). *A good speech. Writing for CEOs*. Accessed on 3<sup>rd</sup> August, 2012 from [http://www.online-Pr.com/Holding/A\\_Good\\_Speech.pdf](http://www.online-Pr.com/Holding/A_Good_Speech.pdf)
- Hubbard, H.** (2000). Discourse: Language in context. In V. Webb, and Kembo-Sure, eds. *African voices. An introduction to the languages and linguistics of Africa*, (pp. 245-285). Southern Africa: Oxford University Press.
- Hurford, J. R., and Heasley, B.** (1983). *Semantics: A course book*. Cambridge: Cambridge University Press.
- Leech, G.** (1983). *The principles of pragmatics*. London: Longman.
- Lyons, J.** (1981). *Language and linguistics. An introduction*. Cambridge: Cambridge University Press.
- Monroe's Motivated Sequence Sample Outline.** Persuasive Speech Outline. Assessed on 3<sup>rd</sup> August, 2012 from <http://people.yzu.edu/~fowens/motivatedSequenceSample.pdf>
- Sinclair, J., and Coulthard, M.** (1975). *Towards an analysis of discourse: The English used by teachers and pupils*. Oxford: Oxford University Press.
- van Dijk, T. A.** (1977). *Text and context: Explorations in the semantics and pragmatics of discourse*. London: Longman.
- Wray, A., Trott, K., Bloomer, A., Reay, S., and Butler, C.** (1998). *Projects in linguistics: A practical guide to researching language*. London: Arnold.
- Yule, G.** (1996). *The study of language*, 2<sup>nd</sup>ed. Cambridge: Cambridge University Press.

# Factors Influencing Sexual Practices of Widows Living with HIV and AIDS in Kondele Location, Kisumu Municipality

By

Okuto-Agache, J<sup>1\*</sup>, Kioli, N. Felix<sup>1</sup> and Nyambedha E.O.<sup>1</sup>

<sup>1</sup>Maseno University, Kisumu, Kenya

\*Corresponding author: [jeremiahokuto@yahoo.com](mailto:jeremiahokuto@yahoo.com)

---

## Abstract

The factors influencing widows' sexual practices have been attributed culture, poverty, and biology without examining the dynamic nature of these factors. This study described these factors. The study was guided by Social Exchange Theory. This theory explains the alternative courses of action while guided by cost-benefit considerations. A cross sectional research design was used in the study. The study population comprised of widows living with HIV and AIDS receiving care and support in Kondele location. Non probability /purposive sampling procedures were used to identify and recruit study participants. The study conducted 17 key informant interviews, 20 individual in-depth interviews and 4 Focus Group Discussion (FGDs). A semi-structured questionnaire was administered to 105 respondents to obtain quantitative data. Statistical Package for Social Scientists (SPSS) Version 18.0 was used for data analysis. MS Excel software was used to present frequencies, percentages, tables, pie charts, and bar graphs. Qualitative data was analyzed using ethnographic content analysis. The findings show that the sexual practices were influenced by biological, economic, psychological, social, cultural and physical factors. Psychological factors were found to influence sexual anesthesia, as there were no widows who experienced total sexual abstinence. The study recommends to policy makers and HIV/AIDS program implementers to include widows living with HIV and AIDS in the list of key populations. Further to this, the study recommends remarriage for young widows as this will assist them manage their sexual desires, fulfill culture and get male companionship.

**Key words:** Sexual practices, culture, poverty, sexual anesthesia, total abstinence.

---

## Background

Different sexual practices across the globe are influenced by different factors (Owen, 1996; UNAIDS, 2009). Heterosexual practices among widows living with HIV and AIDS in America are influenced by the need to have children despite the potential risks for themselves and their children (Barbacci *et al.*, 1989). It is noted that the rapid expansion of access to antiretroviral

therapy increases HIV prevalence through heterosexual contacts in many countries and regions in the world even though it is helping to lower AIDS-related death rates (WHO and UNAIDS, 2009). In other parts of the world, homosexual practices are influenced by stigma as some consider it a form of psychopathology (Stone, 2000) while others attribute it to stunted development due to trauma or parental conflicts (Luise, 1966). In



other countries such as America, homosexuality is widely stigmatized, viewed as a psychiatric disorder reflecting pathological developmental processes (Hager, 1992). In America nearly half of the people surveyed believed homosexuality is a sin (Newsweek Poll, 2000). In the contemporary society, homosexuality has been attributed to social forces such as peer pressure, poverty, personal choices and political strategy against patriarchal relations to challenge the male dominance in sex (Jarry and Jarry, 1991). Studies in Cambodia show that many young widows are forced through poverty to become sex workers (UN Division for the Advancement of Women, 2001). On the other hand, poverty doesn't influence the sexual practices of all widows as widowhood prove to be a period of enriching economic independence and increased status as in Jamaica (Zellner, 2003). In the Western world, poverty is not a major sexual factor among widows as most of them receive statutory pensions automatically upon the death of their husbands (Owen, 1996). Biomedical research however, has failed to show the cause of homosexuality (Mackay, 2001).

Sexual abstinence practices has been attributed to personal choice among older widows in the United Kingdom as they tend not to remarry (Davidson, 1999) due to the absence of interested partners even though they are sexually active (Owen, 1996). In Latin America older widows who occasionally experienced sexual desires abstained because they feared the mockery of their children if they entered new unions and equated their sexual desires with temptation and sin (Owen, 1996). In the United States of America sexual desires and activities of widows during the first 14 months of bereavement was found to be related to the experiences of each individual widow, circumstances surrounding the death of the husband (sudden or delayed), the widow's ages, and the overall sexual satisfaction and intimacy within the marriage (Kansky, 1986). In medieval Europe prosperous families allowed widows to retire to convents

to make a vow of abstinence after being widowed to prevent remarriage and the associated conflict of interest between themselves and former husband's kin (Feldman and Maposhere, 2000).

In sub Saharan Africa, sexual practices among widows have been strongly linked to culture (Owen, 2010; National AIDS and STI Control Program, 2009). In Nigeria, a widow may be forced to have sex with her husband's brothers, or the first stranger she meets on the road, or some other designated male for cultural reasons such as ritual cleansing (Owen, 2010). This ritual cleansing by sex is thought to exorcise the evil spirits associated with death, and if the widow resists this ordeal, it is believed that her children will suffer harm (Owen, 2010). In Zimbabwe, HIV positive women become pregnant to conceal their HIV status from relatives, having known their HIV status before they conceived (National AIDS and STI Control Program, 2009). In some African cultures, refusal to comply with cultural demands may be answered with physical and sexual violence (Owen, 2010). Widows who do not surrender to the cultural demands of male relatives may enter the exploitative and unregulated areas of informal sector labor such as domestic service and sex work (Owen, 2010). In Uganda, Owen identified sexual feelings as an influencing factor in the sexual practices of widows living with HIV/AIDS citing a widow living with HIV/AIDS who said, "I don't wish to kill anyone, but I want to have a man" (Owen, 1996). Similar sentiments were reported in Migori Kenya where a widow living with HIV cried out that "I am dying of passion, I want sex but I am HIV positive and do not want to kill, what can I do?" (Owen, 1996).

In Kenya, heterosexual practices among widows are equally influenced by culture. A study conducted in Siaya District revealed that many educated men hired professional cleansers to engage in unprotected sex with widows (Ocholla-Ayayo, 1996). According to this study, many widows observed the

cultural rites related to widowhood as a survival strategy to protect their property. These sexual practices are complicated by traditional beliefs about condom use. According to these beliefs, condoms spread the pandemic, render the cleansing ritual unsuccessful, reduce sexual pleasure and that condoms are meant for prostitutes (Ocholla-Ayayo, 1996). In addition to this, many widows remarried to a male relative who has some other wives risk being thrown out if they insist on having sex with condoms (Owen, 1996). These practices are fueled by poverty among the widows forcing them into sex work to maintain themselves and their children (Owen, 1996).

A study conducted in Kondele location described the sexual practices of widows living with HIV and AIDS and identified heterosexuality, temporary abstinence, lesbianism and bisexuality [ref]. It is against this background that this paper presents the findings of the study with regard to the factors influencing such practices. This study therefore provided information on the factors influencing the specific sexual practices such as sexual abstinence, heterosexuality, lesbianism and bisexuality in Kondele location.

### **The Problem Statement**

Different sexual practices are influenced by different factors. Heterosexual practices are influenced by rapid expansion and access to antiretroviral therapy, culture, biology and poverty. Previous studies have laid more emphasis on culture, poverty and ARV therapy as the major contributing factors without examining the dynamic nature of these factors. The influence of poverty on widows' sexual practices may not be uniform. Not all widows living with HIV and AIDS are poor. Cultural practices related to widowhood in Sub Saharan Africa have attracted public discourses and transformations especially in rural areas ignoring what happens in urban areas.

Sexual abstinence practices have been attributed to personal choice among older

widows due to lack of interested partner, fear of mockery of their children if they enter new unions and the desire prevent remarriage and the associated conflict of interest from in-laws. There are other factors such as health status, psychological health and social relationships that occur during early experiences of the widowhood. These factors are known to interact with the biological factors affecting women of reproductive age, a natural phenomenon based on monthly cycles.

Homosexuality is a widely stigmatized sexual orientation. It is viewed as a psychiatric disorder while others attribute it to social forces such as peer pressure, poverty, personal choices and political strategy against patriarchal relations to challenge the male dominance in sex. Biomedical research has failed to show the cause. What is influencing this practice is not well understood especially among widows who were once in heterosexual relationships.

As such, the objectives of the current study were as follows:

1. To describe the factors influencing sexual abstinence practices among widows living with HIV and AIDS in Kondele Location.
2. To describe the factors influencing heterosexual practices among widows living with HIV and AIDS in Kondele Location.
3. To describe the factors influencing bisexual and lesbian practices among widows living with HIV and AIDS in Kondele Location.

### **Study Designs and Methodology**

#### **Study site**

The study site was Kondele Location located within Winam Division of Kisumu Municipality. The study area was purposively selected because it had the highest urban population within Winam Division.

#### **Study Population**

The study population comprised of widows living with HIV/AIDS (15-49 years of age) receiving care and support from health facilities and support groups in Kondele

Location of Kisumu Municipality. Additional information was obtained from key informants such as counselors, reproductive health experts, widows' group leaders, lesbian coordinators, religious leaders and provincial administration. The study included all the widows living with HIV and AIDS in the age bracket 15-49 years identified by the community tracers and other key informants. Widowhood in this context referred to all women of reproductive age who had lost a spouse regardless of current partnership status. The study excluded all the widows living with HIV who were sick, had mental disability or were not living in Kondele Location.

### **Sample Size Determination**

Qualitative sample size was determined using saturation concept with N=30 as a starting point as recommended by Griffin and Hauser (1993). HIV positive widows were selected for in-depth interviews and focus group discussions using purposive sampling procedures. Griffin and Hauser (1993) observed that until the definitive answer is provided, perhaps an N of 30 informants is a reasonable starting point for deciding the qualitative sample size. Quantitative sample size was determined using Kathuri and Pals (1993) concept, which says that a minimum of 100 respondents is recommended for a survey research especially where the study population is not known. In this regard, a total of 105 widows living with HIV/AIDS were selected to respond to structured questionnaires.

### **Sampling Procedure**

The study purposively identified health facilities, key informants and support groups providing care and support to widows living with HIV and AIDS. The support groups were purposively selected because they were providing HIV care and economic empowerment to widows living with HIV and AIDS. The key informants mobilized the participants for focus group discussions. The interviews and FGDs continued until a saturation point was reached after 37

interviews. The 105 respondents were identified using snowballing techniques.

### **Methods of Data Collection**

The main methods of data collection were qualitative in nature (informant interviews, focus group discussions and individual in-depth interviews). Interview schedules were used to collect information from key informants. Qualitative methods described the widows' experiences, feelings and opinions. Structured questionnaires captured quantitative data to complement the qualitative findings.

### **Key Informant interview**

The interviews reached a saturation point after 37 interviews (17 key informants, 20 individual interviews). The key informants were 3 psychological/ nurse counselors, 3 program coordinators, 3 provincial administrators, 2 religious leaders, 3 reproductive health experts, 2 women group leaders and 1 community tracer.

### **Focus Group Discussions (FGDs)**

Four (4) FGDs were held with widows living with HIV: 1 FGD with sex workers in Manyatta, 1 FGD with widows from a church based support group, 1 FGD with widows in a psychosocial support group from Nyawita and another FGD with community tracers from JOOTRH. Each FGD had 10 participants and took a maximum of 2 hours. The FGD participants were constituted following the principle of homogeneity in their selection. Following this principle the participants in sex work, abstaining widows from church background and service providers (community tracers) were given their separate sessions. All the FGDs were moderated by the researcher assisted by one note taker.

### **Individual In-depth Interviews**

Individual interviews were held with twenty widows from the Patient Support Centers (PSCs) and community support groups. The interviews collected individual information on the factors influencing their individual sexual practices.

## **Data Analysis**

Quantitative data from all questionnaires were coded, entered in MS-Excel and used as a data base. Statistical Package for Social Scientists (SPSS) Version 18.0 was used for data analysis. MS-Excel was used to present frequency tables, bar graphs, percentages and charts. Qualitative data was analyzed using ethnographic content analysis. Ethnographic content analysis (ECA) is an integrated method, procedure, and technique for locating, identifying, retrieving, and analyzing documents for their relevance, significance, contexts, patterns, processes and meaning (Altheide, 1987). Data was transcribed and checked for emerging themes. Verbatim transcriptions were made for all audio recorded FGDs and interviews. Some quotes from the qualitative data that answered the research questions were identified, translated into English and presented alongside qualitative data to show the feelings, attitudes and perceptions of the participants.

## **Ethical Consideration**

Research permission was granted by Maseno University School of Graduate Studies (SGS) and the District Medical Services Officer, Kisumu. Ethical clearance was sought from the Kenya Medical Research Institute as SSC protocol no. 2321. Confidentiality and privacy of all study participants were observed through coding of questionnaires and interview transcripts. All the identifiers in qualitative research (interviews and focus group discussions) were destroyed after concluding the study. Aggregate reporting was used to seal the identity of the participants.

## **Study Results**

This section presents and discusses the findings on the factors influencing the sexual practices of widows living with HIV and AIDS in Kondele Location, Kisumu Municipality. The section provides information on the socio-demographic profiles of the widows and the factors influencing abstinence, heterosexuality, lesbianism and bisexuality practices.

## **Socio-Demographic Characteristics**

The Socio-demographic characteristics of the respondents included their areas of residence, ages, level of education, denomination, occupation and sexual partnerships as shown in Table 4.

Most of the respondents came from Manyatta "A" sub location 57(54.2%), followed by Nyawita 26(24.8% and Migosi 22(21.0%). Majority of the respondents were in the age group 40-49 years 45(42.9%) followed by 30-39 years 43(41.0%), 20-29 years 16(15.10%) and 15-19 1(1%). Majority of the respondents were of secondary education 49(46.7%) followed by primary education 40(36.1%), post secondary, college 11 (10.5%), no education 3 (2.9%) and post secondary, university 2 (1.9%). On religious affiliations, most of them were Catholics 28(26.7) followed by Protestant Churches (SDAs, ACK and AIC) 38(36.20%) and Moslems 9 (8.6%). Other denominations 30(28.50%) included Legio Maria, Roho, Fueny, roho Israel, roho Musanda and Church of Christ in Africa (CCA). Table 4 further shows that majority of the widows 67(63.8%) were involved in small scale businesses such as sale of chips, fruits, vegetables, tomatoes, ready-made and second hand clothes. The second largest occupation was sex work 19(18.1%) followed by those employed by NGOs and FBOs 9(8.6%). Qualitative findings showed that many of those involved in small scale business were also involved in sex work and used their businesses to identify their sexual partners. In terms of sexual partnerships, Table 4 shows that majority 37(35.2%) were abstaining, 36(34.3%) in casual sexual partnerships, 19 (18.1%) in steady sexual partnerships as 13(12.4%) were remarried or had tried remarriage at one point in their lives.

### ***Factors influencing Temporary Sexual Abstinence***

Temporary sexual abstinence is a situation where the widows were able to abstain from sexual intercourse when psychologically unstable, physically weak due to sickness but

maintained sexual thoughts and feelings. This was a temporary situation, which could easily change when the widows' socio-economic environment changed.

Out of the 105 widows who participated in the study 37(35.2%) respondents were involved in temporary sexual abstinence. Of these widows, majority 18(48.6%) were in temporary abstinence because of fear of either infecting others or getting re-infected, disappointment they found in new relationships 11(29.7%), churches against sex for widows 3(8.1%) and other reasons 5(13.5%) such as mourning experiences, property grabbing, fear of stress from men, not being sure of whom to be with and salvation (See Table1). During the interviews and discussions, other reasons such as poor health status and fear of disclosure of HIV status were cited.

The value for family relationships emerged as a major theme contributing to the sexual abstinence among widows living with HIV and AIDS. Some of the widows were concerned about their family stability arguing that getting into new sexual relationships would interfere with the relationships with their children and other women. Widows who had intimate sexual relationships with their late spouses found it difficult to form new sexual partnerships. They compared the new sexual partners to their late husbands. Other widows abstained after trying new sexual relationships, which they claimed never, benefited them, as the new partners were too demanding. On the other hand, the widows who had bad sexual experiences with their late spouses suffered loss of sexual interest fearing the new partners would behave the same way. A widow living with HIV and AIDS who abstained for 10 years and was found 'partnering' shared her experiences:

*I had never moved out of marriage since I got married and when I was telling my husband to stop moving with ladies, he refused to listen. I started to look at all men as enemies. All these made me not to have sexual feelings and that is how I*

*managed to abstain for 10 years. So I hated men and anything to do with a man. When that feeling of hate stayed for long in me, the urge was reduced even though at times I could feel very little of it.*

The above excerpt shows a relationship that occurs between sexual feeling and past sexual relationships. In this regard, a widow can manage to abstain due to loss of sexual interest based on her past and when this situation improves, abstinence practice fades away confirming the fact that the abstinence practice in this scenario is temporary in nature. This was previously described as sexual anesthesia (Havelock 1927).

Other widows had partner identification difficulties. Such widows claimed that men never attended support group meetings where they could be singled out for relationships. A key informant, a young widow living with HIV and supporting other young widows in a support group remarked as follows:

*"I think the issue of getting the right man to settle with is a challenge as you will be thinking, 'The best man I can settle with is a man who knows me, a man who is HIV positive like me and getting such a man is difficult as you know men have poor health seeking behaviors. Furthermore, most of men don't attend support group meetings claiming most support groups are women led".*

Other widows living with HIV abstained because of the nature of business they were involved in such as selling fish. They felt that such businesses were tiring and therefore denied them strength to indulge in sex. Others suffered from community and self-stigma. For example, being seen with a man was viewed as having taken the man. In this current study, a church counselor acknowledged church stigma saying

*"People have stigmatized widows in the church as a widow talking about sex in the church is considered to be promoting sin". Some of the widows abstained as they were still bargaining with themselves to*

*find out how they got infected claiming that “this situation of self bargain has made our hormones sleep”.*

### **Factors influencing heterosexual practices**

Heterosexual practices were influenced by sexual feelings (biology), poverty, culture and other social factors as shown in Table 1. *The table shows that the sexual feelings 12(27.9%) had the greatest influence on their heterosexual practices followed by poverty 10(23.3%), cultural influences 9(20.9%). The other factors 7(16%) included age, peer pressure, improved health status, circumstances surrounding the death of the husband, the social support received during the mourning period and alcohol use.*

### ***The influence of sexual feelings***

The influence of sexual feelings was further explored and the findings presented in Table 2. The data in this table shows that out of the 105 widows interviewed, 75 (71.4%) experienced monthly sexual feelings. It further shows that the majority 32(30.5%) who experienced sexual feelings were aged 30-39. Individual in-depth interviews and focus group discussions supported age as an important factor in the experience of sexual feelings. Two widows living with HIV and AIDS shared their experiences during a focus group discussion in Manyatta:

*“It is age because my husband died when I was 24 years... but another one interrupted, “You were better off as you were 24 years old. I was 18 years old imagine! During this period, you will be forced to look for your brother in-law and at times they are brought for you”.*

From other FGDs conducted, it was learnt that nearly all the widows living with HIV and AIDS experienced sexual feelings of varied intensity. Key informants and widows living with HIV and AIDS agreed that sexual feelings experienced monthly by women of reproductive age influenced their sexual practices. A widow living with HIV and AIDS from Manyatta shared that:

*“Personally, there are times I really feel I need a man and say to myself that I should not suffer like*

*this as I am not the one who killed my husband. During this time, my private part gets hot, itchy and swollen and at times I have to slap it until I release is when I relax”.*

A reproductive health expert who said further confirmed the biological nature of the sexual feelings:

*“The sexual feelings are biological in nature and vary from woman to woman. During ovulation, when the ovum matures and travels along the fallopian tube, the woman will experience changes in the secretion of the mucous. The mucus becomes thin, the body temperature rises and there is also that feeling of having sex. At times the feelings overpower them”.*

It was further discovered that not all widows living with HIV and AIDS had similar experience in a uniform manner as the experiences depend on several factors such as the stress level, the availability of food and the degree of social problems experienced by individuals. A widow living with HIV and AIDS from Nyawita observed that:

*“When one is stressed, that feeling is not there but when you are relaxed, eating well and no school fee problems and listening to music, the urge resurfaces”.*

In another interview, a widow living with HIV and AIDS supported this view saying that:

*“Sexual desires will only be there when poverty is reduced. When you don't have food, your body will have no sexual energy”.*

The sexual feelings were related to treatment scale up especially for those who were on ARVs and other forms of care. For example, a nurse counselor, a key informant, observed that:

*‘we talk about strength and sex and you know ARVs improve quality of life, personal well being and strength’.*

A widow living with HIV and AIDS from a support group in Manyatta confirmed this by her experience as follows:

*“After burying my husband at 38 years old, I became sick, my body became cold and I thought I could do without a man. I had no feelings for a man and I knew my vagina was only for urinating. But later on, when I learnt that I could be healthy and my physical health improved, my blood started flowing normally, my breast was back to its original shape, my skirt started fitting me again after being on ARVs. I started feeling bodily reactions. My body started asking me to do something. At times my heart could tell me, ‘Today I need a man for sex’. I had lost feelings completely and it all came back in full force”.*

A reproductive health expert working with HIV positive widows was of the same view saying that the sexual feelings are physical and noted as follows

*‘when women are sick and frail, they cannot have sex, somebody has to be strong to have sex’.*

#### **Poverty and sexual practices**

Results from the current study showed that a more economically empowered widow earned respect while the less economically empowered indulged in sex abuse. A key informant from Manyatta, a widow living with HIV and AIDS observed that:

*“The widows who are economically empowered are socially respected and people like shemejis (in-laws) would be going to them for help instead of using money to influence them for sex”.*

On the contrary opinion, another widow living with HIV and AIDS leading a support group in Manyatta observed that those who are poor ‘sell’ their bodies to get money for their upkeep. These women have many sexual partners not because of personal sexual desires but because of poverty.

All the discussions from FGDs and interviews agreed that the widows living with HIV and AIDS be economically empowered. Those empowered and buy goods are better off than those who are

selling. The argument is that those buying ‘give their own terms’. But if you are selling, ‘you become more vulnerable to the conditions of the buyer’. Some people felt that poverty is now replacing culture in influencing sexual practices of widows. It was argued that culture has been overtaken by poverty. What is important is bread for the day not enjoyment of sex.

#### **Culture and sexual practices**

The study further explored the influence of culture on heterosexual practices. The study confirmed that culture has an influence over the widows’ sexual practices but this act was on the decline. No All discussants and interviewees agreed that ‘there is no woman being forced to fulfill the cultural norms related to sex these days. They further confirmed that some widows living in Kondele kept secret sexual partners to help them fulfill specific cultures related to sex ‘voluntarily. These specific cultures include the need to have children to continue the family lineage and the need to construct a house or home. A counselor and a key informant leading a support group of widows living with HIV and AIDS, observed that during the time for fulfilling cultural norms, there is a lot of travelling to the rural areas giving reasons such as follows: ‘I am going home to plant, I am going home to harvest...’

#### **Other influencing factors**

The other influencing factors affecting sexual practices were related to circumstances surrounding the death, social support received by the widows during the mourning period, clinic teachings, loneliness and peer pressure. The circumstances surrounding death such as sudden or delayed, overall sexual satisfaction and intimacy within the marriage influenced the onset of the sexual feelings. Peer pressure came from the widows who were in sexual relationships as they encouraged the others to join them. Commenting on peer pressure, a widow living with HIV and AIDS observed that at times you might be in a group of other widows and they are encouraging you and I

quote, “*kwani wewe umekaaje? Si utafute*”...( what is wrong with you, why can't you look for a partner...”)

### ***Factors influencing the Lesbian and Bisexual practices***

Table 1 shows that poverty 10(40%), sexual feelings 9(36%), fear of infecting men or getting re-infected 2(8%), alcohol, improved health status 2(8%), and religion 2(8%) influenced lesbian and bisexual practices.

### ***Bisexuality, Lesbianism and Poverty***

Poverty, the greatest factor influencing lesbian and bisexual practices, was further explored. Poverty leads to sexual work that occurs between the old rich widows, young unemployed girls and school girls. A 28-year-old lesbian key informant from Nyawita claimed that most widows in Nyawita know her as a practicing lesbian and ‘at times give a lot of money in exchange for sex’. She further asserted that ‘they use a lot of money their husbands give them on people like me to satisfy them sexually’. Another young lesbian key informant who was serving bisexual women within Kisumu pointed out that her clients got more sexual satisfaction from her than from their male partners and added that ‘we are trying to perfect our sexual practice to compete with men and very soon, married men will not match us’. She noted that most of her bisexual clients enjoyed lesbianism more than heterosexuality but continued with heterosexual practices to respond to the views of the society, which hold that heterosexual contact is the ‘right’ practice.

### ***Bisexuality, Lesbianism and Religion***

Table 3 shows that Catholics led in lesbianism 4(44.4%) followed by Protestant that include SDAs, AIC, ACK 3(33.4%) and Moslems 2(22.2%). The Moslems led in bisexuality (43.7%) followed by Catholics (31.3%), and protestant Churches 4(25%). During interviews with key informants, an Islamic religious leader confirmed the involvement of the Moslem women in bisexuality and lesbianism. He acknowledged that this practice is not in

public domain because Islam prohibits discussions on sexual relationships unless witnessed.

### **Discussion**

Majority of the respondents, based on the socio-demographic profile, were illiterate. The high literacy was perhaps due to the urban setting of the study site. Most of the respondents resided in Manyatta sub location, the largest slum dwelling in Kisumu Town for low income earners. This shows that most of the respondents were generally poor widows living with HIV and AIDS. Most of the respondents were in the age bracket 40-49 years, showing that most of them were old and had received care long enough to be socially empowered to join support groups related to HIV and AIDS. Most respondents were Catholics. Catholic Church in Kisumu Town is perhaps in the forefront in supporting HIV and AIDS activities compared to other religious faiths. It was earlier observed that institutions that are directly affiliated to Catholic Church and supported by the same are the largest care providers of HIV and AIDS in the world Flanigan (2009).

In terms of sexual partnerships, most of the respondents claimed to practice sexual abstinence followed by those in casual sexual partnerships. Sexual abstinence practices for widows living with HIV and AIDS is difficult to confirm. None of the widows was found to practice total sexual abstinence devoid of sexual thoughts and feelings. Previously, it was observed that the state of "sexual abstinence" is a completely vague and indefinite as it can, may, or even must, involve masturbation (Havelock, 1927). The abstinence practice was therefore described as ‘Temporary sexual abstinence’. These findings present the widows’ temporary sexual abstinence practices as a product of the family relationships emerging from past and present family experiences. Some expressed love for their children that they had to sacrifice their own sexuality. Others experienced disappointments derived from their previous relationships and that they



were reluctant to form new ones. Others were victims of long illnesses of their spouses, which deprived them of their conjugal rights for long. Deprivation-satiation proposition argues that when an individual is deprived of some rewards for a long time, the individual learns to do without it (Homans, 1974)). Other factors related to temporary sexual abstinence identified in the study were bitter mourning experiences, difficulties of partner identification due to comparison with their late spouses, fear of HIV status disclosure and the hard stand taken by the church on widows' sexuality. This hard stand by the church compelled some widows to use long term family planning methods to prevent pregnancy so as to continue getting church support. These widows talked of abstinence since it is the term 'socially accepted' while in real sense they were in secret relationships. This was in agreement with a study by Havelock that strict sexual abstinence does not exist at all (Havelock, 1927). Other widows were able to sustain sexual abstinence because of the strenuous nature of the businesses they were involved in.

Heterosexual practices were influenced by sexual feelings, poverty, culture and gender disparities. The widows' sexual feelings were of biological nature and were related to the monthly ovulation. According to the medical experts women who ovulate experience monthly sexual feelings due to their biology and psychological states and this experience is not uniform for all women but worse for young widows (Dawson *et al.*, 1998). These authors further explain the experience of the sexual ovulation as follows and I quote "During ovulation on the fourteenth day, the estrogen levels drop; one of the follicles ruptures and releases its eggs. After the egg breaks from the ovary (ovulation), the positive feelings peak at this stage but are not uniform for all women".

The young widows had a lower experience of the sexual feelings. Majority had just been bereaved and perhaps due to the

mourning experiences, was still in the state of "sexual anesthesia". ARVs treatment Scale up was found related to the increase in sexual activities. This was not because ARVs increase libido but because they improve the quality of life with the corresponding improvement in sexual functioning. This confirms previous reports that rapid expansion and access to ARVs therapy is helping to lower AIDS-related death rates and at same time contributes to increases in HIV prevalence (WHO and UNAIDS, 2009). This scenario suggests that HIV infection is likely to rise in Nyanza. The province has the greatest number of HIV positive adults on care and support (National AIDS and STI Control Program /Ministry of Health (2008). Sexual feeling has been identified as a challenge among widows living with HIV and AIDS in Migori Kenya and Uganda (Owen, 1996). While it is true that the high HIV prevalence in Nyanza has been attributed to risky cultural practices (Ocholla-Ayayo, 1996), the experience of sexual feelings among widows living with HIV and AIDS cannot be ignored as it is biological rather than psychological (Dawson *et al.*, 1998). Improving the poverty level and psychological states of widows living with HIV and AIDS will have a corresponding improvement in their sexual feelings and functions. The contradictions presented by the ideational (moral values) and the sensate experiences of the widows lead to cognitive dissonance among them. When individuals are faced with such situations, many will respond to their sensate needs. This in itself is a risk factor in HIV infection taking into account the fact that these widows don't have designated partners to respond to their sensate needs related to sex.

Sexual feeling therefore is biological, psychological and physical in nature and needs a multidisciplinary approach to control it. There is need to learn from other countries such as India, which have tried remarriage bureaus to help widows living with HIV, and AIDS manage their sexuality (Khullar, 2007). Religious practices can also

be of help as other religions such as Islam allows remarriage for widows living with HIV and AIDS as a way of helping them manage their natural sexual feelings after HIV testing.

Economic status influenced the heterosexual practices of HIV positive widows in Kondele. The current study showed that economically empowered widows enjoyed independence, respect and provided support to their in-laws. Some of these economically empowered widows 'bought sex' from poor desperate young men to take care of their sexual feelings. On the other hand, the less economically widows suffered humiliation from their in-laws with some ending up in sex work. Their involvement in sex work was to help them support their children, meet their medication needs and food. Sex due to poverty was described as worse off as it involved unprotected multiple sexual partnerships. These findings reveal that the spread of HIV require economic intervention as well. Fighting culture, improving the health of the widows living with HIV and AIDS without addressing poverty might not lead to a holistic HIV prevention program. Economic activities can be used as opportunities for engaging widows as "Economic empowerment will make the widows spend their energy in their business during the day leaving no strength for night sexual activities".

Heterosexual practices were related to culture where sex was used to fulfill cultural rites. Heterosexual practices due to culture in Kondele Location were voluntary in nature, as the widows did not experience forced sex due to cultural reasons. The widows residing in Kondele often travelled back to their rural homes to fulfill cultures related to sex during planting, harvesting, marriage ceremonies and construction of new homes. They got involved in these practices to free themselves psychologically. Some widows who were natives of Kondele location kept secret sexual partners to 'help them' during such cases. The concept of making a new home, *goyo dala* especially for widows with

sons requires the widow to construct her home before the sons and sex must be involved for its completeness. The need to fulfill these cultural norms 'forces' the widows to 'voluntarily' look for sexual partners to help them meet their normative roles. Previously, a normative exchange orientation was used to explain how culture views exchange relationships based on the societal views on acceptable and appropriate behavior (Blau, 1964).

Bisexual and lesbian practices were influenced mainly by poverty, culture and religion. Poverty led to sex work between the old rich widows, young unemployed girls and school girls. Culture influenced bisexual practices among widows living with HIV and AIDS who had lesbian sexual orientation. These widows in bisexual relationships were in partnerships with married women who enjoyed lesbian practices but kept their male partners in response to the heteronormative views of the society, which hold that heterosexual contact is the 'right' practice. Religious influences were found among the Catholics, SDAs and Moslems. The Catholic church had greater influence because it allows gays and lesbians full participation in the church and rejects as sinful any acts of prejudice and discrimination against them (Human Rights Campaign, 2013). Again, it is known, that the number of Catholics receiving care and support in Kisumu is generally higher than the number from other denominations. Catholic Church is known to be the largest care provider of HIV and AIDS in the world (Stein, 1993). The involvement of the SDAs in lesbianism and bisexuality can be explained by the fact that SDA faith does not allow any other form of sexual relationships for widows except in remarriage cases. In cases of remarriage, the Church requires the widows to get remarried to the unmarried young men, widowers or divorced men. This is difficult to achieve and so the widows who need church support find it easier to claim they are abstaining, keep secret partners or get involved in homosexual practices. More Moslem widows with HIV and AIDS

practiced bisexuality to hide their lesbian identity. This is attributed to the harsh religious penalties given to those involved in homosexuality. Majority would want to appear to be in heterosexual relationships because Islam allows remarriage for widows and continue practicing lesbianism for their own sexual satisfaction.

**Conclusion**

The study concluded that factors influencing heterosexual practices were biological (sexual feelings), economic (poverty), psychological (mourning experiences), social (education, peer pressure, loneliness and alcohol use), cultural (fulfillment of rites) and physical (improved health conditions). Other factors were related to age, sexual satisfaction and intimacy in previous relationship, circumstances surrounding the deaths and the ‘difficult men’.

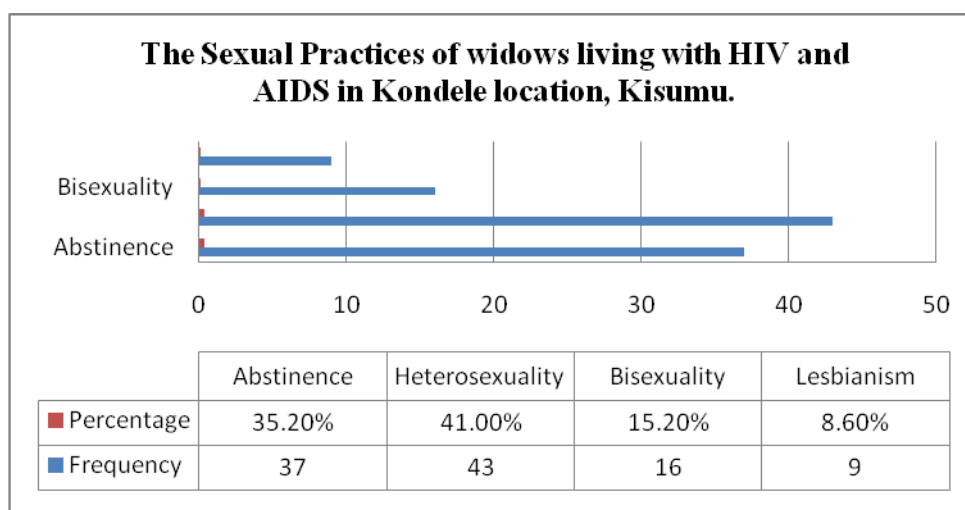
The study further found out that there were two types of abstinence practices: temporary sexual abstinence and total sexual abstinence influenced by different factors. Total or permanent sexual abstinence was influenced by ovulation and the associated experiences. On the other hand, temporary abstinence

was found to be influenced by psychological processes related to widowhood experiences (mourning experiences, stigma, and family relationships) and the widows’ physical health. In this context, poor health conditions were found to suppress the biological factors leading to temporary sexual abstinence described as sexual anesthesia. Generally, there were no uniform factors influencing sexual abstinence among widows living with HIV and AIDS. The factors influencing lesbian and bisexual practices were found to be economic (poverty), biological (sexual feelings) and social (fear, alcohol use, culture stigma, religion).

**Recommendations**

The study recommends that for effective HIV prevention campaign, sexuality of widows with HIV and AIDS needs to be given a special focus. The study therefore recommended the promotion of through remarriage bureaus as practiced in countries such as India as remarriage will help them meet their sexual needs, fulfill cultures related to sex and fight poverty through identified supportive men.

**List of Tables and figures**



**Figure 7. Widows’ Sexual Practices**

**Table 1. Factors influencing the sexual practices of widows living with HIV and AIDS in Kondele, Kisumu.**

Factor	Frequency	Percentage
<i>Abstinence Practices</i>		
Fear of infection/re-infection	18	48.6%
Disappointment in new relationship	11	29.7%
Church against sex for widows	3	8.1%
Others reasons	5	13.5%
<b>Total</b>	<b>37</b>	<b>100%</b>
<i>Heterosexual Practices</i>		
Sexual feelings	12	27.9%
Poverty	10	23.3%
Culture	9	20.9%
Improved health status	5	11.6%
Others	7	16.3%
<b>Total</b>	<b>43</b>	<b>100%</b>
<i>Bisexual and Lesbian Practices</i>		
Poverty	10	40.0%
Sexual feelings	9	36.0%
Fear of infection or re-infection.	2	8.0%
Improved health status	2	8.0%
Others	2	8.0%
<b>Total</b>	<b>25</b>	<b>100%</b>

**Table 2. The Widows who Experienced Sexual Feelings Based on age groups**

Age group	Frequency	Percentage
15-19	1	1.0%
20-29	12	11.4%
30-39	32	30.5%
40-49	30	28.5%
<b>Total</b>	<b>75</b>	<b>71.4%</b>

**Table 3. Influences of Religion on Lesbian and Bisexual Practices**

Religion	Lesbianism		Bisexuality	
	No.	%	No.	%
Catholic	4	44.4%	5	31.3%
Protestant (SDA, ACK and AIC)	3	33.4%	4	25.0%
Moslems	2	22.2%	7	43.7%
<b>Total</b>	<b>9</b>	<b>100.0%</b>	<b>16</b>	<b>100.0%</b>

**Table 4. Socio-Demographic Characteristics**

<b>Characteristics</b>	<b>Frequency</b>	<b>Percentage</b>
<b><i>Residence</i></b>		
Manyatta “A”	57	54.20%
Migosi	22	21.99%
Nyawita	26	24.80%
<b>Total</b>	<b>105</b>	<b>100.00%</b>
<b><i>Age Group</i></b>		
15-19	1	1.00%
20-29	16	15.10%
30-39	43	41.00%
40-49	45	42.90%
<b>Total</b>	<b>105</b>	<b>100.00%</b>
<b><i>Level of Education</i></b>		
Primary	40	36.10%
Secondary	49	46.70%
Post Secondary College	11	10.50%
Post Secondary University	2	1.90%
No Education	3	2.90%
<b>Total</b>	<b>105</b>	<b>100.00%</b>
<b><i>Religion / Denomination</i></b>		
Catholic	28	26.70%
Protestant (ACK, SDA, AIC)	38	36.29%
Moslems	9	8.60%
Others	30	28.50%
<b>Total</b>	<b>105</b>	<b>100.00%</b>
<b><i>Occupation</i></b>		
Civil Servant	3	2.90%
Employed NGO/CBO	9	8.60%
Business	67	63.80%
Unemployed	2	1.90%
Sex Worker	19	18.10%
Others	5	4.80%
<b>Total</b>	<b>105</b>	<b>100.00%</b>
<b><i>Sexual Partnerships</i></b>		
Remarried Widows	13	12.40%
Not remarried steady partners	19	18.10%
Not remarried casual partners	36	34.30%
Abstaining Widows	37	35.20%
<b>Total</b>	<b>105</b>	<b>100.00%</b>

**Acknowledgements**

The authors would like to acknowledge the support and institutions for their great support. We specifically thank all the widows living with HIV and AIDS who

participated in the study, Dr. Aggrey Otieno Akula (Medical Superintendent, Kisumu District Hospital), Nyanza Provincial General Hospital PSC staff (Jane Oyomba, Hulda Kongere, Dolly and Pamela Spoo), Professor Collins Ouma (Maseno University)

and Judith Akinyi of KEMRI Kisumu. More appreciation goes to Rev. David Chuchu (DCM Kenya), Mr. Tom Okeyo (Plan Bondo), Doreen Baraza (Plan Homa Bay), Linda Omedo (Plan Bondo), Grace Oduor (Plan Kisumu), Rev Osumba Ataro (Child Care Project, ELCK), Lilian Okinyo (Child Care Project, ELCK) for their moral and financial support. More sincere thanks go to all members of staff, department of Sociology and Anthropology of Maseno University, Diakonia Compassionate Ministry (DCM) and Muhoroni Sub-District Hospital.

## References

- Adetunji, J.** (2001). HIV and Young Age Widowhood in Sub Saharan Africa. *Journal of Health and Human Services Administration*, 24 (3), 259-278.
- Altheide, D. L.** (1987). *Ethnographic Content Analysis* (Vol. 10). Newbury Park CA: Sage.
- Ambasa-Sisanya, C.** (2007). Widowhood in the Era of HIV/AIDS: A case study of Siaya District, Kenya. *Journal of Social Aspects of HIV/AIDS*, Vol. 4.
- Barbacci, M., Chaisson, R., and Anderson, J.** (1989). Knowledge of HIV serostatus and pregnancy decisions. *International Conference on AIDS, abstract no. MBP 10.5:223*.
- Blau, P. M.** (1964). *Exchange and Power in Social Life*. New York: John Wiley & Sons.
- Dawson, S. P.** (1988). *Your Sexual Cycles*. Retrieved from The secrets Our Body Clock Reveal.
- Feldman, R. and Maposhere, C.** (2000). Voices and choices: A participatory research and advocacy study of reproductive health and rights of HIV positive women in Zimbabwe. *The XIII International AIDS Conference*, (pp. 9-14). Durban.
- Flanigan, T. P.** (2009). *The Catholic Church and HIV and AIDS*. Retrieved April 12, 2013, from Catholic News Agency: <http://www.catholicnewsagency.com/column.php?n=750>.
- Griffin, A.** (1993). The voice of the customer. *Marketing Science*, 12 (1), 1-27.
- Hager, B.** (1992). Get Thee to a Nunnery: Female Religious Clausturation in Medieval Europe. *Ethnology and Sociobiology*, 13, 385-407.
- Havelock, E.** (1927). *Studies in the Psychology of Sex Volume VI: Sex in relation to Society*. Retrieved December 18th, 2012, from <http://www.psyplexus.com/ellis/83.htm>.
- Homans, G. C.** (1974). *Social Behavior: Its Elementary Forms* (Rev. ed.). New York: Harcourt Brace Jovanovich.
- Human Rights Campaign.** (2013). *Stances of Faiths on LGBT Issues: Roman Catholic Church*.
- Kansky, J.** (1986). Widows sexual practices. *PubMed Winter*, 12 (4), 307-21.
- Kathuri, N.J. and Pals, D.A.** (1993). *Introduction to educational research*. Njoro: Egerton University, Education Materials Center.
- Mackay, J.** (2001). Global sex: sexuality and sexual practices around the world. *Sexual and Relationship Therapy*, 16 (1).
- National AIDS and STI Control Program /Ministry of Health.** (2008). *Kenya AIDS Indicator Survey 2007: Preliminary Report*. Nairobi: Government Printer.
- National AIDS and STI Control Program.** (2009). *2007 Kenya AIDS Indicator Survey: Final Report*. Nairobi: NASCOP/Government Printer.
- Newsweek Poll.** (2000). Storrs C: Roper Center or Public Opinion Research.
- Ocholla-Ayayo, A.** (1996). *Psychical, social and cultural issues relating to HIV/AIDS containment and transmission in Africa with special reference to Kenya*. Nairobi: Population Studies Research Institute, UON.
- Owen, M.** (1996). *A World of widows*. London: Zed Books Ltd.
- Owen, M.** (2010). *Widows in the Third World Nations*. Retrieved April 2nd, 2013, from [Third-World-Nations.html](http://www.third-world-nations.html): <http://www.deathreference.com>
- Stein, T. S.** (1993). Overview of new developments in understanding homosexuality. In M. B. J. M. Oldham, *Review of psychiatry* (Vol. 12, pp. 9-40).

Washington, DC: American Psychiatric Press.

**Stone, M. H.** (2000). Psychopathology: Biological and psychological correlates. *Journal of the American Academy of Psychoanalysis*, 28, 203-235.

**UN Division for the Advancement of Women.** (2001). *Widowhood: invisible women secluded or excluded*. W o m en2000.

Division for the Advancement of Women/DESA.

**WHO and UNAIDS.** (2009). *2009 AIDS Epidemic Update*. Geneva: UNAIDS.

**Zellner, S. L.** (2003). Condom Use and the Accuracy of AIDS Knowledge In Côte d'Ivoire. *International Family Planning Perspectives*, 29 (1).

## Ethnolinguistic Impact of Social Network in Kinubi Vitality

By

Yakub Adams<sup>1\*</sup>, Peter M. Matu<sup>2</sup>, David O. Ongarora<sup>3</sup>

*1; Department of Linguistics, Maseno University, Maseno, Kenya*

*2; Department of Languages and Communication Studies,*

*3; The Kenya Polytechnic University College, Nairobi, Kenya*

*\*Corresponding author: [yakubdms@yahoo.co.uk](mailto:yakubdms@yahoo.co.uk)*

---

### Abstract

This paper forms part of a broader investigation into Kinubi maintenance in Kibera. The current paper is anchored to the ongoing discussion of the significance of social networks in language maintenance, particularly as attributed to Kinubi which is spoken by an urban minority linguistic community. The Nubians attest to sociolinguistic studies which posit that social networks are structures which are based on the mutual engagement of a people who share the same linguistic norms and several patterns of behavior. The study focuses on the various network dimensions that have enabled the ethnolinguistic vitality of this minority language in a multilingual urban set up. Social networks are extremely variable but in this study the dense, multiplex networking is put to in-depth examination.

**Key words:** Kinubi, social networks, minority, ethnolinguistic vitality

---

### Introduction

Indigenous language maintenance has recently received enthusiastic support from language educators and scholars (Wiley, 2005). Immigrants from linguistically different backgrounds have long faced the task of maintaining the language of origin in their children. Zanden (1990) argued that maintaining one's heritage language in the host country decreases the feelings of powerlessness and anomie, which often accompany the entry of immigrants and their children into a different mainstream culture. These sentiments from Zanden (1990) provide a gap for the study of an immigrant

language such as Kinubi which has its roots in the Sudan and a matrix Arabic language.

Kinubi is prevalently spoken in Kenya, Uganda and to a lesser degree in southern Sudan. There is a sense in which Kinubi can be considered a creole language. This is in relation to the socio-historical conditions under which Kinubi became established as a native language. Kinubi language and culture are believed to have originated in southern Sudan. Wellens (2005) observes that the events that fostered the development of Kinubi started around 1820 when northern Arabic speakers moved southward.



Due to the influence of Arabic, Kinubi is considered as an Arabic creole having originated from the southern part of the Sudan. Winford (1997) states that the identification of pidgins and creoles is based on a variety of often conflicting criteria including function, historical origins and development, formal characteristics or a combination of all these. The convergence of a number of linguistic features and non-linguistic factors may help define pidgins and creoles.

A pidgin is a marginal language which arises to fulfill certain restricted communication needs among people who have no common language (Todd, 1990). A Pidgin is a learned language created for specific purposes and is not the native tongue of any person. Todd (1990) subsequently defines a Creole as a language which arises when a pidgin becomes the mother tongue of a community. It is a comprehensive language that is capable of expressing all communication needs of the speakers. Kinubi is considered as being a creole having undergone a pidginization process at the beginning (Heine, 1982).

With regard to the concern of this study, three varieties of creoles namely Turku, Kinubi and Juba-Arabic emerged as distinctive languages in the Sudan. They originated from the same place, the southern Sudanese region at the same period, somewhere between 1854-1888 (Miller, 1985). Throughout this period, Arabic expanded progressively and became the ruling and religious language of the Muslim Sudanese kingdoms and the trade language for the entire region. Arabic was the mother tongue for the Arab groups and spread to non-Arab groups through Islamization. Hence a number of former non-Arab groups became progressively Arabic-speaking. The presence of the Egyptian military in the Sudan gave rise to an Arabic dialect known as Bimbashi Arabic which developed into three further varieties: Turku in Chad, Juba-Arabic in southern Sudan and Kinubi in Kenya and Uganda. The trade also included

acquisition of cheap and forceful slave labour by the Viceroy of Egypt at that time. The Viceroy, Mohammed Ali, also enlisted the services of black Sudanese men into the Egyptian army.

The people who today call themselves "Nubi" came to Uganda and Kenya around the turn of the 20<sup>th</sup> century. The language has a background rooted within the Egyptian conquest of the Sudan. The soldiers in Equatoria province, the southernmost province of the Sudan, sided with the English and Egyptians against the Mahdi and when the troops of the Mahdi invaded Equatoria, some fled into Uganda. Meldon (1908) notes that in 1890, Captain Lugard found about 8000 men, women, and children and other camp followers in western Uganda. Lugard had been looking for cheap replacement for his more expensive Swahili and Sudanese troops and for extra manpower to hold the British territories of Uganda and Unyoro. Lugard was acting in the interests of the Imperial British East African Company which at that time was trying to make a commercial success of Uganda. In 1901, the King's African Rifles were formed and the Nubian soldiers were incorporated into them as regular forces, thus becoming part of the 4<sup>th</sup> (Uganda) Battalion (Hansen, 1991). Hansen adds that part of the Nubi soldiers were sent to Nairobi where they were settled in 1902. The other part remained in Uganda around Bombo. These are the ancestors of the present day Nubians living in Kenya and Uganda.

Thus, at the end of the World War I, the Nubians who came to Kenya were rewarded with land in Kibera, Nairobi because of their service in the British Army (Heine, 1982). Kibera is a corrupted word from the Kinubi word 'Kibra' which means a place of many trees or forests. It is noted that the Nubians still strongly associate with Kibera though it is now a crowded slum area of people from virtually every community in Kenya. Kibera as an informal settlement within the city of Nairobi, started more than a hundred years ago. Kibera is like Kenya in microcosm and

is home to members of all Kenyan (African) ethnic groups. The settlement is divided into a number of 'villages', each with its own characteristic ethnic make-up and although most villages have people of all ethnic groups, often one group is dominant.

The multilingual nature of Kibera is expected to give rise to competition between languages in the various domains of interactions. This may further be complicated by the presence of majority languages such as English, Kiswahili and Sheng as well as some indigenous languages. The Kinubi speakers are a minority in this region and hence are expected to face linguistic challenges which may lead to them shifting to a language of majority. However, contrary to the researched expectations of sociolinguistics studies expectations, Kinubi seems to thrive in vitality and it has even gained recognition from the Kenya government. This is demonstrated by the 2009 census where the Nubians were, for the first time, recognized as a distinct speech community. It is therefore the sole objective of this study to ascertain the impact of the multiplex social networks on Kinubi vitality and its subsequent effect on language maintenance.

### **Social Network Perspective**

According to Matsumoto and Britain (2009), 'Social network' was one of the first social variables recognized as potentially alternative or complementary to 'socio-economic class' in sociolinguistics. Social network models have been applied to communities where the social class distribution of community speakers is uneven or problematic, for example, small rural and non-industrialized communities (Gal, 1979); urban ethnic minority communities (Edwards, 1986); urban migrant or immigrant communities (Li Wei, 1994); and adolescent communities (Labov, 1972). From these models, Kinubi can be considered as an urban migrant and immigrant community as well as an urban ethnic minority community.

A social network can be defined as the aggregate of relationships contracted by an individual with others (Milroy, 1980). In a later study, Croft (2000) identifies a social network as a group of individuals who have a common language and have the same probability of communicating with each other if there is a reason to linguistically interact. A network is thus a group of people who know each other in some capacity and who are linked to each other by interpersonal ties of different types and strengths. Landweer (2008) points out the importance of the network of the social situations that are supportive to ethnolinguistic vitality of the language under consideration. Multiplex relationships are very important in maintaining the identity of the community and its language. Dense multiplex network is in existence when ego relates to other individuals in a number of capacities simultaneously.

Thus, ego might be the neighbor of a man, who is his brother, who also serves as the local catechist for community children including ego's children. Of course ego and his brother are from the same clan and share clan obligations with the same group of people. Thus, in this example, ego and his brother share at least four relational links: parentage, neighborhood, religious instruction, and clan membership (Landweer, 2008).

Landweer (2008) also mentions the findings of Milroy (1980) which describe the value of dense multiplex networks of a minority vernacular within a wider societal context. To review, a social network is said to be dense when each person to which ego is linked in some kind of relationship with one another is also linked in relationship with one another. The simultaneous nature of relationships across the community in a dense multiplex social network results in internal reinforcement of whatever cultural values are held dear across that society. Thus the societal norms regarding language use are reinforced along with every other societal norm. In the case of a single language, such

networks can serve to insulate speakers, isolating and protecting them from language contact pressures towards change.

According to the concept of social networks the individual is influenced by various factors when it comes to language use. For example, the use of different languages, dialects or accent can mark people as members of a particular social network. Milroy (1980) and Blom and Gumperz (1972) suggest that a close-knit network structure is an important factor with regard to contributing to language maintenance because speakers are able to unify and resist linguistic and social pressure that comes from outside the group. With the earlier studies as departure points for this theory, Landweer (2008) points out the importance of the network of the social situations that are supportive to ethno-linguistic vitality of the language under consideration. Multiplex relationships are very important in maintaining the identity of the community and its language. Dense multiplex network is in existence when “ego relates to other individuals in a number of capacities simultaneously. Landweer (2008) inquires if there is then a network of social relations supportive of the local language.

Landweer’s indicator of social networks draws on results of earlier studies such as that of Milroy (1980) into the maintenance of vernacular norms among social groupings in Belfast, Northern Ireland. In that study, Milroy demonstrates and explains the correlation between dense, multiplex, territorially-based social networks and language maintenance. Briefly put, Milroy’s research shows that individuals who interact almost exclusively within close-knit communities tend to share common communicative preferences, and to exert pressure on others in their network to follow the same norms. Not only so, but a closed social group will often actively choose specifically those linguistic features that differ from features in the standard language as a way to assert and display group distinctiveness. Thus, there are strong social

forces at work within dense, multiplex networks that promote non-standard speech varieties and enforce uniformity within the group.

Density refers to the number of connections in the network. In a denser network, people from one domain such as a work place know people from another domain such as a mosque. Multiplicity refers to the quality of the interconnections. Multiplex networks are multi-stranded, whereby an individual is connected to ego in a number of capacities for example neighbour as well as workmate. Networks that are both dense and multiplex might be described as strong and close-knit network (Milroy, 1980). In an ego-network approach, focus is placed on estimating the range or size of individual contacts and the effects of those ties on ego. A network is said to be of high density if individuals (A, B, C, D, E) who are in a relationship with any ego (are in his/her social network) are also in relationship with each other.

Many other linguists have applied these findings on social networks to language maintenance questions elsewhere. Schooling (1990) used social networks methodology to create a typology of individuals with predictive power for situations of language maintenance in Melanesia. Schooling (1990) also mentions Cubitt (1973) who developed the notion of social network clusters. The four key clusters she mentions arise from kinship, neighborhood, occupation and voluntary association. Another linguist Tosi (1999) touched on the role of close-knit communities in maintaining language in Australia and other areas. These reviewed studies provided worthwhile discussion points in the understanding of the Kinubi situation in an urban set up like Kibera, Nairobi.

### **Methodology**

This study is a smaller part of a broader ethnolinguistic analysis of Kinubi maintenance in Kibera. It focuses on ascertaining Kinubi vitality through the social network concept. In the larger study, a

variety of data were gathered involving nearly a year of participant observation in various language use domains, 30 tape-recorded ethnographic interviews as well as many hours of informal discussions. For this article, however, we selected only the relevant data to investigate the mechanism of language maintenance with special reference to social network.

The researcher engaged the descriptive research design to guide the study. The research participants and sites were purposively sampled. This sampling procedure was aided by the snowballing technique which enabled contact with the best data sources for the study. A combination of participant observation and ethnographic interviews was generally employed in an attempt to enhance their reliability. The study used simple plain language of the participants' choice to ask for their social network perspective and also observed them in order to authenticate the interviews.

### **Theoretical Framework**

This study was interested in Kinubi vitality through the available social networks within the Nubian community. There are certain ways put in place to determine the vibrancy of a speech community. This is normally referred to as ethnovitality. The vitality theories tend to explain the phenomenon of an ethnic group's linguistic maintenance, shift or eventual death. The UNESCO *ad hoc* expert group on endangered languages in their report to the UNESCO programme on Language Endangerment (Brenzinger, Arianne, Tjeerd, Collete, Michael, Osahito, Nicholas, Osamu and Ofelia, 2003) identified six major factors affecting language vitality. They formed the foundation from which most vitality theories are inherent.

In this study, however, the indicators of Ethnolinguistic Vitality theory by Landweer (2008) were employed to ascertain Kinubi vitality in Kibera. These indicators were derived from Giles, Bourhis and Taylor (1977) who posit that the vitality of an

ethnolinguistic group is that which makes a group likely to behave as a distinctive and active collective entity in intergroup situations. Landweer's (2008) vitality indicators were all used in the analysis of the broader study but in the present paper, the indicator on population and group dynamics was the only one applied. The indicator inquires if there is then a network of social relations supportive of the local language.

### **Data Presentation and Discussion**

The main objective of this study is to examine how variable social networks in the Nubian community have enabled the vitality of Kinubi in Kibera, Nairobi. The researcher employed a variety of tools in collecting the data relevant to the study. Both the interview and observation techniques were co-opted to provide reliability in the findings. The two sources of data collection are discussed in this section concurrently as appropriate.

In answering to questions relevant to social networks issues, some of the interviewees attributed the close knit aspect of the Nubians to the Islamic religion which encourages the concept of humility and friendship towards fellow Muslims. Such a social network impacted positively on the language behaviour of the Kinubi speakers. From the several interviews carried out, a section of the transcripts used here focus only on the impact of social networking in Kinubi maintenance. Those transcripts are adapted to suit this study and are renamed for the benefit of the present discussion. These transcripts (now labeled as Transcript 1, Transcript 2, Transcript 3 and Transcript 4) were originally in Kinubi but were translated into English for academic comprehension in this paper.

#### **Transcript 1**

**Interviewer:** Where do you do your shopping?

**Respondent:** You know, first of all as a Muslim, you must develop the religion. Improve the religion thus I will go to shops

owned by Muslims even if they are not Nubi speaking.

### Transcript 2

**Interviewer:** What steps is the Nubian community taking to maintain the language?

**Respondent:** They have these many small cultural groups such as Sports Club, Sister Club and earlier there were Young Rovers, Spearhead and other groups. They even invite Nubians from other far flung regions such as Eldama Ravine and Kibigori. This Easter if you are here you will find all the Nubians will be here. The Sister club will also go to Uganda. Their food, their music, generally cultural enhancement is celebrated. Culture comprises of languages.

### Transcript 3

**Interviewer:** What efforts are the Nubians making to maintain their language?

**Respondent:** In Kibera, the Nubi do have cultural days. They hold activities like weddings. They also do have Nubian Nights which stress to people to speak Kinubi and keep to their Nubian traditions.'

### Transcript 4

**Interviewer:** Is Kinubi therefore the language you use most in Kibera?

**Respondent:** You know, there are so many people from other tribes who can speak Kinubi. Even here at the funeral they are present. Do you see those people passing? Most of them are Luos, Luhyas and Kikuyus and they are here to attend this funeral. They also like Kinubi. People like Kinubi for speaking and socializing.'

Transcript 1 stresses the Islamic factor in cementing the closeness of the Nubi people. This was in reference to out-group interaction. The respondent stressed that

*'you know first of all as a Muslim you must start with those places owned by fellow Muslims so that you build your religion.....even if they are not Nubians'.*

The members of the linguistic group apply the Islamic principle of unity among the faithful. This encourages the people to keep

track of one another. The respondent views Islam as the tool of cohesion amongst the Nubians. This relationship between religion and speech community can be drawn due to the fact that the Nubians in Kibera are mostly Muslims. The respondent would first want to associate with those who are Muslims and this will bring contact amongst the native Nubians. The Islamic religion acts as the preference that creates the close-knit nature of the community. This follows Milroy (1980) who says that individuals who interact almost exclusively within close-knit communities tend to share common communicative preferences and to exert pressure on others in their network to follow the same norms.

In Transcript 2, Nubian social networks are expressed in a nutshell. The respondent states how the Nubians in Kibera still maintain contact with the other Nubians in other parts of Kenya *such as Eldama Ravine and Kibigori*. He also mentions Uganda as another region which the Kibera Nubians still associate with. Such maintenance of connection with other Nubians ensures the vitality of the language.

In the Nubian community, there is usually an annual cultural celebration that brings together all Nubians. The respondent in Transcript 2 also informed the researcher that the Nubians in Kibera likewise go to Uganda for similar Nubian cultural fetes. This is exemplified from his assertion that *'They have...Sports club, Sister club..Young Rovers. They even invite Nubians from..Eldama Ravine..will also go to Uganda'.*

The network developed along the lines of culture has enhanced Kinubi vitality a lot. This follows Milroy (1980) who says that a network that has been long established and that is likely to continue has considerably more influence on an individual than do temporary relationships. The cultural association between the Nubians in Kenya and others in, for instance, Uganda, encourages Kinubi vitality. The fact that this

is being done annually supports Milroy's assertion.

The researcher had also asked whether or not the respondents are members of any of the Nubian cultural organizations; a question which was aimed at identifying the language used during the cultural activities and meetings. Some of the respondents, for example the respondent in Transcript 3, said they were not registered members of such cultural organizations but they were aware that things like cultural activities strengthen the solidarity of the Kinubi speakers as such groups keep track of their people. The greater membership of the Nubian cultural organizations was mainly among the womenfolk who are said to have associations that unite them. They use such groupings to vitalize the Nubi culture and create the aspect of togetherness. Referring to Cubitt's (1973) kinship clusters, it can be stated that the Nubians seem to have culture-specific activities and relationships that derive from a person's membership or position in the community and family. Thus, such cultural networks improve the Kinubi vitality in Kibera.

It was equally gathered from the interviews that Kibera Nubians still have very robust kinship ties and contacts with Nubians in other regions in Kenya as well as Uganda and the Sudan. Their networking is further strengthened by the annual Easter cultural celebrations which are held in rotational basis either in Kenya (in Kibera, Kibos, Kisii) or Uganda (in Bombo or Mbale). This was a contributing factor to linguistic and cultural maintenance in that the Kibera Nubian speakers have not severed their ties with the Kinubi speakers of Uganda and others from within Kenya.

It can hence be put deductively that the social networking of the Kinubi speakers seems to enhance the vitality of the language. As already mentioned earlier, due to the immigrant population into Kibera and inter-ethnic marriage within the Nubi community, this factor of ethnolinguistic

vitality seems to operate positively in the case of the Nubi people. It was observed that funerals and weddings were venues where the Kinubi speakers would come together.

The researcher similarly observed that although there were never death announcements in the press or electronic media, the attendance by fellow Nubians would be remarkable. Those in attendance would even be Nubians from outside Kibera. In one of the funerals the researcher had the opportunity to attend, the presence of even the non-native Kinubi speakers was impressive. Through snowballing the researcher managed to interview some of those 'Nubians'. The respondent in Transcript 4 alluded to the fact that the Kinubi speakers are close and they socialize much thus they would be updated on issues such as the demise of another Nubian.

The respondent in Transcript 4 aptly represents the fact that even non-Nubians who speak Kinubi keep track of such things as Nubian funerals as they consider themselves part of the community for instance the respondent in Transcript 4 stated that

*'You see those people passing? Most of them are Luos and Luhyas and they are here to attend this funeral'.*

It is evident that the non-native Kinubi speakers are always in touch with the other native speakers otherwise they would not know such personal issues like death in a family since the community does not announce deaths through the media. Therefore, it can be concluded that the Kinubi speaking community in Kibera seems to exhibit a dense multiplex social network and is active in the maintenance of this language. The Kinubi speakers' social network indicates the language of choice. This language of choice is Kinubi since it is largely the language of communication in such personal events like funerals. Schooling (1990) mentions that language is crucial to the very existence of social networks and networks cannot exist without

communication between their individual members. Kinubi language use in Nubi social networks can then be assured and would stand out as the dominant language in such networks.

### Conclusion

In summary, it is important to note that social networking is a significant factor in Kinubi vitality and features such as cultural practices and the Islamic religion are among the boosters of this maintenance. The researcher had observed that the Nubian community is close-knit in terms of place of living and neighbourhood. They are populated within specific areas such as Makina, Kambi Muru, Nyumba Kubwa and so forth. This promotes the dense, multiplex networking among them hence Kinubi maintenance. It is noted that sparse, uniplex networks are not bound so closely together. Speakers are more likely to come into contact with many more different ideas and influences in general and to be much freer to change if it suits their needs (Schooling, 1990).

The Nubi people in Kibera are still in touch with their kin in other places such as Uganda and southern Sudan. They are also in contact with the other Nubians in other parts of Kenya such as Eldama Ravine, Kibigori, Kisumu, Kibos, Migori, Kisii etcetera. This networking encourages unity of purpose in all that they do. Simply put, the Kinubi speakers seem not to have forgotten where they came from and that close association with the others out of Kibera serves the language positively as a tool for maintenance.

### References

**Blom, J. and Gumperz, J.** (1972). Social meaning in linguistic structures: Code-switching in Norway. In J. Gumperz and D. Hymes (Eds.), *Directions in sociolinguistics*, New York: Holt, Rhinehart, and Winston. 407-434.

- Croft, W.** (2000). *Explaining language choice: An evolutionary approach*. Harlow: Longman.
- Cubitt, T.** (1973). Network density among urban families. *Boissevain Mitchell*, 67- 82.
- Edwards, W. F.** (1992). Sociolinguistic behavior in a Detroit inner-city black neighborhood. *Language in Society* 21: 93-115.
- Gal, S.** (1979). *Language shift: Social determinants of linguistic change in bilingual Austria*. New York: Academic Press Inc.
- Hansen, H. B.** (1991). The pride and decline of a migrant community. The Nubians in Uganda and the military profession. In M. Lundahl and Th. Svenson (Eds.) *Agrarian society in history* (pp. 318-342). London: Routledge.
- Heine, B.** (1982). The Nubi Language of Kibera: An Arabic Creole Grammatical Sketch and Vocabulary. In B.Heine and W.J.G.Mohlig (Eds.) *Language and atlas of Kenya, vol.III*. Berlin: Dietrich Reiner.
- Labov, W.** (1972). The linguistic consequences of being a lame. In William Labov, *Language in the Inner City*. Philadelphia: University of Pennsylvania Press. 255-297.
- Landweer, L. M.** (2008). *Endangered languages: indicators of ethnolinguistic vitality*. Dallas: SIL International.
- Li, W.** (1994). *Three generations, two languages, one family*. Clevedon: Multilingual Matters.
- Matsumo, K. and Britain, D.** (2009). The role of social networks in understanding language maintenance and shift in post-colonial multilingual communities: The case of the Republic of Palau in the Western Pacific. *Essex Research Reports in Linguistics* Vol. 58.2, Oct 2009.
- Meldon, J. A.** (1908). Notes on the Sudanese in Uganda. *JAS* 7. 123-146.
- Miller, C.** (1985). Les enjeux de l'arabisation au sud Soudan. *Peuples Mediterraneens* 33: 43-53
- Miroy, L.** (1980). *Language and social networks*. 2<sup>nd</sup> edition. Oxford: Blackwell.

- Schooling, S. J.** (1990). *Language maintenance in Melanesia*. Dallas: SIL International and University of Texas at Arlington.
- Todd, L.** (1990). *Pidgins and creoles*. Routledge and Kegan Paul Ltd.
- Tosi, A.** (1999). The notion of 'community' in language maintenance. In G. Extra and L. Verhoeven (Eds) *Bilingualism and migration* Berlin: Mouton. 363-377.
- UNESCO.** (2014). *Language vitality and endangerment*. (Online). Available at [www.portal.unesco.org/culture/en/e.v.php-URL](http://www.portal.unesco.org/culture/en/e.v.php-URL) last accessed on May 31, 2014.
- Wellens, I. H. W.** (2005). *The Nubi language of Uganda: An Arabic Creole in Africa*. Leiden: Brill.
- Wiley, T. G.** (2005). The reemergence of heritage and community language policy in the U.S national spotlight. *The Modern Language Journal*, 89, 594–600.
- Winford, D.** (1997). Introduction: On the Structure and Status of Pidgins and Creoles. In A.K Spears and D. Winford (Eds.), *The structure and status of pidgins and creoles* Amsterdam-Philadelphia: John Benjamins. 1- 34.
- Zanden, V.** (1990). *American minority relations*. New York: McGraw-Hill.



# Analysis of Consumer Preferences for Indigenous Chicken in Kisumu City, Kenya

By

Fredrick Onyango Aila<sup>1\*</sup>

*1; Department of Business Administration, School of Business and Economics, Maseno University, Private Bag, Maseno.*

*\*Corresponding author e-mail: [fredrick.aila@gmail.com](mailto:fredrick.aila@gmail.com)*

---

## Abstract

The aim of this study was to analyze consumer preferences for indigenous chicken in Kisumu City, Kenya. The sub-aim was to assess how consumer attitudes on biosecurity principles influence consumer preferences. To the best of the researcher's knowledge, no previous research has investigated the link between consumer attitudes and consumer preferences mediated by biosecurity principles and moderated by consumer characteristics. Using new scale named consumer attitudes on biosecurity principles for indigenous chicken, two variables namely, perceived benefits of biosecurity principles and perceived concerns of biosecurity principles were factor analyzed explaining 42.73% variance and good fit  $\chi^2=19.575(p=.106)$   $df=13$ . Out of a sample of 360 respondents, 281 (female=135) questionnaires were returned. A further 49 (13.6%) questionnaires had missing items, therefore only 232 (64.4%) questionnaires were used for analysis. The questionnaire was reliable,  $\alpha = .936$ . A binary logistic regression analysis fitted these two variables together with consumer characteristic variable to predict intention to consume indigenous chicken. Nagelkerke  $R - Square = .453$  indicated a greater improvement from null model to fitted model. The goodness-of-fit Hosmer and Lemeshow (H-L) Test,  $\chi^2 = 14.094$ ,  $df = 8$  ( $p = .079 > .050$ ) indicated a good fit. The Wald criterion demonstrated that only occupation ( $p = .040$ ) and perceived benefits of biosecurity principles (PBBP) ( $p = .022$ ) made a significant contribution to prediction. Therefore, intention to consume indigenous chicken was significantly dependent on two variables: positively on a factor named perceived benefits of biosecurity principles and positively on a variable named occupation. Therefore, it was concluded that perceived benefits of biosecurity principles and occupation significantly predicted preferences for indigenous chicken in Kisumu City, Kenya. Findings have policy and managerial implications.

**Key words:** Intention to consume; occupation; perceived benefits; perceived concerns; biosecurity principles.

---

## Introduction

Kisumu City is situated on 0°6'S 34°45'E at an altitude of 1,131m (3,711 ft) within the

Lake Victoria basin of Kenya along the East Asia/East Africa bird migratory flyway (Bird Life International, 2013). The city principally is the leading commercial, trading, fishing, industrial, communication and administrative centre in the Lake Victoria basin. Poultry is cited as an economic subsector that could be targeted to spur the growth of this region (Ndirangu *et al.*, 2009; KAPP, 2013). The city is the most significant destination for chicken from the region (Onim, 2002; Kagira and Kanyari, 2010; Bett *et al.*, 2012).

Given the city's location along the wild bird migratory route, it is highly susceptible to the introduction and spread of the highly pathogenic avian influenza (HPAI) (Nyaga, 2007a; Omiti and Okuthe, 2008). It also risks other zoonotic infections such as human psittacosis (Jacques, 2006; Beeckman and Vanrompay, 2009), gastroenteritis, and *Campylobacter* infections especially in children causing diarrhea (Lehner *et al.*, 2000; Padungton and Kaneene, 2003) among others. *Campylobacter* was found to be prevalent in 77% of poultry products in the market in western Kenya (Osano and Arimi, 1999), moreover, *Salmonella* is seldom controlled. These are known biosecurity concerns.

Consumers on the contrary were reported to be willing to pay 23.26% per kg more for indigenous chicken meat and 41.53% for eggs (Bett *et al.*, 2011). Therefore, the mediating role of biosecurity principles on the link between attitudes and preferences is unknown. The aim of this study was to analyze consumer preferences for indigenous chicken in Kisumu City, Kenya. Its sub-aim was to assess how consumer attitudes on biosecurity principles influenced consumer preferences because to the best of the researcher's knowledge, no previous research had investigated the link between consumer attitudes and consumer preferences mediated by biosecurity principles and moderated by consumer characteristics. This was because the determinants of consumer preferences for indigenous chicken given biosecurity

principles and consumer characteristics in Kisumu City were unknown.

The concept attitude is defined as an overall evaluation that expresses how much one likes or dislikes an object, issues, person, or action (Wells, 2014). Fishbein and Ajzen (2010) defined consumer attitudes as learned predispositions to respond in a consistently favourable or unfavourable manner with respect to a given object. They asserted that attitudes should be measured by a procedure which locates the subject on a bipolar affective or evaluative dimension vis-à-vis a given object. Moreover, they proposed Fishbein Multi-Attribute Model (FMAM), an established framework for explaining attitude, intention, and choice. FMAM holds that an attitude towards a brand is formed through the summation of varying amounts depending on the strength of the affect associated with salient brand attributes (Wyer, Jr. and Srull, 2014). The individual's beliefs and qualitative aspects (judged goodness or badness) components are therefore no longer regarded merely as indicants of brand attitude. Rather, they are seen as the determinants of the attitude.

Therefore, by placing respondents on affective bipolar dimensions (Kim, 2009), the study was able to construct a new scale to measure consumer attitudes on biosecurity principles in Kisumu City hitherto unknown in literature. The new measure was validated through maximum likelihood exploratory factor analysis (Fabrigar *et al.*, 1999; Conway and Huffcutt, 2003; Costello and Osborne, 2005). This returned a 2-factor solution explaining 42.730% variance with an insignificant goodness-of-fit  $\chi^2 = 19.575$  ( $p = .106$ )  $df = 13$ . A total of 4 items were positively correlated to factor I and was named perceived benefits of biosecurity principles for indigenous chicken. Three other items were negatively correlated to factor II and therefore named perceived concerns of biosecurity principles for indigenous chicken. This finding was consistent with Fishbein and Ajzen (2010) in measuring the concept. Therefore, the two

factors permitted a connection between consumer attitudes and biosecurity principles.

Consumer characteristics are most often used as the basis for market segmentation (Schiffman and Kanuk, 2009; Kotler, 2010; Hoyer *et al.*, 2012). Demographic segmentation divides customers into segments based on demographic values such as age, gender, family size, family life cycle, income, occupation, education, religion, race, generation, social class and nationality (Armstrong and Kotler, 2005). These characteristics are vital measurable statistics of a population. Moreover, they are the most accessible, and cost-effective way to identify a target market. In addition, they are easier to measure and add meaning to any other variables measured in a study.

Demographic variables are associated with the sale of many products and services and provide a description of the target customers so that media buyers and others can reach a desired target market (Larsen, 2010). Other than demographics, media usage and cultural factors were seen as important factors that influence purchase decisions for poultry products (Institute of Grocery Distribution, 2007). Socio-economic status (SES) was included in a study that assessed the comparative and interactive effects on consumers' purchase intention for the GM food in China (Kim, 2009). A study in Ghana aimed at assessing factors influencing the consumption of pork and poultry meat in among 224 students undergraduate found that demographic variables: gender, age, family income level, religion, region, personality type and year in school affected the attitude towards poultry and pork consumption (Antwi-Boateng *et al.*, 2013). However, the optimal mix of consumer characteristics moderating the elicitation of consumer preferences for indigenous chicken in Kisumu City was unknown. Therefore, both null and alternate hypotheses were set to guide the study as a result. These were:

$H_0$ : There were no significant preferences for indigenous chicken in Kisumu City, Kenya.

$H_1$ : There were significant preferences for indigenous chicken in Kisumu City, Kenya.

## Methodology

### Research Design

The study was designed as a descriptive research involving collection of quantitative information that could be tabulated along a continuum in numerical form (Creswell, 2014). The type of descriptive research employed was survey research, specifically a descriptive survey which permitted both description of events and hypothesis testing. Survey research commonly includes a type of measurement that goes beyond descriptive statistics in order to draw inferences (Tashakkori and Teddlie, 2010; de Vaus, 2013). The study was conducted among 5,738 university students aged 18 years and above enrolled in the seven campuses located in Kisumu City, Kenya as at April 2012. A sample of 360 respondents was drawn using systematic sampling technique proportionately for each campus (Saunders *et al.*, 2012). Only 281 (78%) useful questionnaires were returned during the data collection week in July 2013. A further 49 (13.6%) questionnaires had missing items, therefore only 232 (64.4%) questionnaires were used for analysis. The questionnaire was reliable at Cronbach's Alpha  $\alpha = .936 > .600$  (Hair *et al.*, 2010). The items were constructed as on 7-point agreement scale (Vagais, 2006). A 2-factor solution was extracted using maximum likelihood factor analysis. It had 4 items converging on factor I and 3 items converging on factor II respectively with factor loadings  $> .500$  indicating convergent validity (Trochim, 2006). The difference between items cross-loading on two factors was  $> .20$ , factor inter-correlations  $r = -.590 < .700$  and squared factor inter-correlations  $r^2 = 34.81\%$  less than variance explained  $VE = 42.73\%$  indicated discriminant validity (Trochim, 2006).

## Model Specification

A binary logistic regression model was specified and used for analysis to address the aim of this study. The binary logistic model assumed that the underlying stimulus ( $ln$ ) is a random variable which predicted the probability of indigenous chicken preference. The cumulative logistic model was econometrically specified as (Pindyck and Rubinfeld, 2000):

$$P_i = F(Z_i) = \frac{1}{1 + e^{-(a + \sum \beta_i x_i)}}. \quad (1)$$

Where  $P_i$  = the probability that a consumer preferred indigenous chicken given  $X_i$ .

$Z_i$  = the cumulative logistic function.

$X_i$  = the  $i^{th}$  explanatory variable.

$\alpha, \beta_i$  = regression parameters to be estimated.

$e$  = the base of the natural logarithm.

For ease of interpretation of the coefficients, the logistic model was written in terms of the odds and log of odds. The odds ratio was the ratio of the probability that a consumer preferred indigenous chicken ( $P_i$ ) to the probability that he or she did not prefer indigenous chicken ( $1 - P_i$ ).

$$\text{That is, } \left( \frac{P_i}{1 - P_i} \right) = e^{Z_i}. \quad (2)$$

Taking its natural logarithm, Equation 2 yielded:

$$\ln = (P_i / 1 - P_i) = Z_i = a + \beta_i X_i + \dots + \beta_n X_n. \quad (3)$$

If the disturbance term  $U_i$  was taken into account, the binary logistic model became:

$$Z_i = a + \sum_{i=0}^n \beta_i X_i + U_i. \quad (4)$$

The parameters of Equation 4,  $\alpha$  and  $\beta$ , were estimated using the maximum likelihood estimation (MLE) method (Maddala, 2008). The general theoretical model for this study was formalized by modifying Caracciolo *et al.* (2011):

$$Y = \text{Pr ob}(Y_i = 1) = F(\beta'_{CC} CC_i + \beta'_{PBBP} PBBP_i + \beta'_{PCBP} PCBP_i + U_i). \quad (5)$$

in which

$i = 1, 2, \dots, n$  = the index of interviewees

$CC_i$  = indicated the group of variables relative to the respondent's socio-economic and demographic characteristics. It replaced and extended the  $SE_i$  variable in Caracciolo *et al.*, (2011).

$PBBP_i$  and  $PCBP_i$  = the group of perceived concern and perceived benefit variables that represented attitudes on biosecurity principles. These variables represented factor scores extracted from exploratory factor analysis. Together the two groups of variables replaced the group of variables represented by  $TCFOB_i$  in Caracciolo *et al.*, (2011).

$F$  = a known function.

$\beta'$  = a vector of parameters to be estimated.

$U_i$  = autonomous error term ( $\varepsilon \sim N(0, \sigma^2)$ ).

Given the wide array of the consumer characteristic variable, Equation 5 was expanded to accommodate all explanatory variables. The expanded empirical model was specified as:

$$Y_i = a_i + \beta'_{PBBP} PBBP + \beta'_{PCBP} PCBP + \beta'_{Income} Income + \beta'_{Age} Age + \beta'_{TEA} TEA + \beta'_{Gender} Gender + \beta'_{Occupation} Occupation + \beta'_{Residence} Residence + \beta'_{PLoc} PLoc + \beta'_{MaritalStatus} MaritalStatus + \beta'_{MSRH} MSRH + \beta'_{CIncl} CIncl + U_i. \quad (6)$$

Where

$Y_i$  = the dependent variable representing behavioral intentions to consume indigenous chicken in the week following the interview where intention to consume indigenous chicken=1, otherwise, 0.

$PCBP_i$  = the continuous predictor variable extracted through factor analysis representing perceived concern attitudes on biosecurity principles.

$PBBP_i$  = the continuous predictor variable extracted through factor analysis representing perceived benefit attitudes on biosecurity principles.

$Income_i$  = the respondent's average monthly income level measured on a metric scale in Kenya Shillings.

$Age_i$  = the respondent's age in years measured on a metric scale.

$TEA_i$  = respondent's terminal education age measured on a metric scale.

$Gender_i$  = a dummy variable for respondent's gender where female=1 otherwise, 0.

$Occupation_i$  = the respondent's occupation where employed=1, otherwise, 0.

$Residence_i$  = the respondent's place of residence where residing in the urban part of the city=1, otherwise, 0.

$PLoc_i$  = the respondent's preferred purchase location for indigenous chicken where live market=1, otherwise, 0.

$MaritalStatus_i$  = respondent's marital status where married=1, otherwise, 0.

$MSRH_i$  = the continuous variable extracted through factor analysis representing the suitability of media seen read, and heard by respondent in communicating indigenous chicken biosecurity principles to consumers.

$CIncl_i$  = a dummy variable representing the respondent's cultural inclination in respect to indigenous chicken consumption where cultural inclination=1, otherwise, 0.

More than one criterion was employed in examining model fit (Malhotra, 2011). Hosmer-Lemeshow (H-L) test, the inferential test needed its chi-square to be statistically insignificant for good fit (Hosmer and Lemeshow, 2000). Nagelkerke R square test was the descriptive measure for improvement from the null or intercept only model (Nagelkerke, 1991).

## Results

### Descriptive Statistics of Explanatory Variables

Table 1 indicates the frequency distributions of consumer characteristics. Majority of respondents, 196 (70%,  $N = 281$ ) had gross monthly income below Ksh. 20,000. Monthly incomes upto Ksh 40,000 and Ksh 60,000 had less than 40 respondents combined. Some 17 respondents (5%,  $N = 281$ ) had monthly incomes above Ksh. 60,000. Majority of respondents, 197 (70%,  $N = 281$ ) were aged between 21 and 40 years. Close to 30% ( $N = 281$ ) respondents were below 20 years of age. Only two percent of respondents were aged

above 40 years. Majority of respondents (61%,  $N = 281$ ) had spent less than 16 years in formal education. About one third indicated spending between 16 and 20 years in formal education. Less than 10% ( $N = 281$ ) of the respondents had stayed in the education system for more than 20 years. Female respondents were 48% ( $N = 281$ ) of all respondents. Two thirds of the respondents (66%,  $N = 281$ ) resided in the urban part of Kisumu City. Another 77 (27%,  $N = 281$ ) respondents resided in the peri-urban regions of the city. The rest resided in the rural part of the city. One third of the respondents 32% ( $N = 241$ ) indicated they would source their preferred

indigenous chicken products from their own flock while 21 respondents (9%) reported they would source the products from their neighbours and relatives. A total of 51 (21%,  $N = 241$ ) of the respondents said they would source the products from live market traders while only 11% ( $N = 241$ ) indicated they would source the products from poultry stalls and butcheries. Another 9% ( $N = 241$ ) indicated they would source the products from supermarkets, 12% ( $N = 241$ ) said they would source the products from hotels and restaurants while 1% ( $N = 241$ ) said they would source the products from the slaughter house. A total of 40 respondents did not respond to this item.

**Table 1. Frequency Distributions of Consumer Characteristics**

Variable		Frequency	%	Cumulative %
Average Income (N=281) Ksh	BELOW 20,000	196	70	70
	20,000-39,999	38	14	84
	40,000-59,999	30	11	95
	60,000-79,999	9	3	98
	80,000-99,999	4	1	99
	100,000 AND OVER	4	1	100
Age in Years (N=281)	BELOW 20 YEARS	78	28	28
	21-30 YEARS	163	58	86
	31-40 YEARS	34	12	98
	41-50 YEARS	4	1	99
	OVER 50 YEARS	2	1	100
Terminal Education Age (Years) (N=281)	BELOW 16 YEARS	171	61	61
	16-20 YEARS	92	33	94
	21-25 YEARS	13	5	99
	26-30 YEARS	4	1	100
	OVER 30 YEARS	1	0	100
Residence Classification (N=281)	URBAN	184	66	66
	PERI-URBAN	77	27	93
	RURAL	20	7	100
Preferred Place Location (N=241)	OWN FLOCK	76	32	32
	NEIGHBOURS/RELATIVES	21	9	41
	LIVE MARKET TRADERS	51	21	62
	POULTRY STALLS AND BUTCHERIES	29	11	73
	SUPERMARKETS	21	9	82
	HOTEL/RESTAURANT	33	14	96
	SLAUGHTERHOUSE	2	1	97
	OTHER	8	3	100
	Total	241	100	

Source: Main survey data, 2013

Table 2 indicates consumer characteristics descriptive statistics. Mean income was  $M = 1.57$  ( $SD = 1.053$ ) indicating average income was within Ksh 20,000-39,999 range. Mean age was  $M = 1.89$  ( $SD = .714$ ) meaning the average age fell between 21-30 years. Average terminal education age

(TEA) was  $M = 1.48$  ( $SD = .687$ ) meaning it fell below 16 years. Mean gender was  $M = .48$  ( $SD = .5$ ) (see Table 2) corresponding to the frequency results given that the female gender was coded 1 in the questionnaire. Table 2 further indicated that mean marital status was  $M = .48$  ( $SD = .5$ )

because the item was binary coded where 'married' was coded 1 (one). At the same time, mean occupation was  $M = .47$  ( $SD = .5$ ) representing employed respondents because the item was binary coded. Mean residence was  $M = 1.47$  ( $SD = .622$ ) signifying the

respondents resided in the urban part of the city. Mean preferred place of purchase was  $M = 3.19$  ( $SD = 1.999$ ) whereas mean cultural inclination was  $M = .88$  ( $SD = .109$ ) indicating that respondents were culturally inclined to consuming indigenous chicken.

**Table 2. Consumer Characteristics Descriptive Statistics**

Demographic Profile	N	Range	Min	Max	Mean		SD	Variance
					Statistic	SE	SD	Statistic
Average Income (KSh)	281	5	1	6	1.57	0.063	1.053	1.110
Age in years	281	4	1	5	1.89	0.043	0.714	0.510
Terminal Education Age (Years)	281	4	1	5	1.48	0.041	0.687	0.472
Gender	281	1	0	1	0.48	0.030	0.500	0.250
Marital status	281	1	0	1	0.48	0.030	0.501	0.251
Occupation	281	1	0	1	0.47	0.030	0.500	0.250
Residence classification	281	2	1	3	1.42	0.037	0.622	0.387
Preferred Purchase Location	241	7	1	8	3.19	0.129	1.999	3.994
Cultural inclination choice	281	1	0	1	0.88	0.020	0.331	0.109
<b>Media Seen Read and Heard</b>								
Television	281	1	0	1	0.85	0.021	0.357	0.128
Radio	281	1	0	1	0.75	0.026	0.433	0.188
Newspaper	281	1	0	1	0.72	0.027	0.449	0.201
Magazines	281	1	0	1	0.62	0.029	0.486	0.236
Internet	281	1	0	1	0.59	0.029	0.492	0.242
Branded logos	281	1	0	1	0.54	0.030	0.499	0.249
Mail	280	1	0	1	0.50	0.030	0.501	0.251
Product placements	281	1	0	1	0.51	0.030	0.501	0.251
Bill boards	279	1	0	1	0.48	0.030	0.500	0.250
Word of mouth	281	1	0	1	0.56	0.030	0.497	0.247
Social media	280	1	0	1	0.57	0.030	0.496	0.246

SE=Standard Error, SD=Standard Deviation. Source: Main survey data, 2013.

Table 2 also presents the descriptive statistics for the suitability of media seen read and heard (MSRH) where 1 = *suitable* otherwise 0. The means of each medium was: television  $M = .85$  ( $SD = .357$ ), newspaper  $M = .75$  ( $SD = .433$ ), magazine  $M = .62$  ( $SD = .486$ ), Internet  $M = .59$  ( $SD = .492$ ), branded logos  $M = .54$  ( $SD = .499$ ), mail  $M = .50$  ( $SD = .501$ ), Product placement  $M = .51$  ( $SD = .030$ ), billboards  $M = .48$  ( $SD = .030$ ), word of mouth  $M = .56$  ( $SD = .030$ ) and social media  $M = .57$  ( $SD = .030$ ) respectively. The fact that nearly all channels had means  $M > .50$

confirmed that consumers patronized multichannel media was consistent with literature (Pilotta *et al.*, 2004; Storey and French, 2004).

### Factor Analysis of Selected Explanatory Variables

Maximum likelihood exploratory factor analysis resulted in a 2-factor solution as described in Table 3. This finding permitted examination of the relationship between consumer attitude and biosecurity principles for indigenous chicken in Kisumu City which was previously not possible. Prior to this research, no scale existed in literature to measure consumer attitudes on biosecurity principles for indigenous chicken. This prevented empirical examination of the scale and its relationship with other Consumer Behaviour scales.

**Table 3. Consumer Attitudes on Biosecurity Principles for Indigenous Chicken Factor Structure Matrix**

Questionnaire Construct	Factor	
	1	2
<b>Goodness-of-fit test, <math>\chi^2 = 19.575, df = 13 (p = .106) &gt; .050</math></b>		
1. K12: Stocks selected for breeding are sourced from unregulated sources such as local markets, relatives, friends, local hatcheries etc.	<b>.725</b>	-.388
2. K15: Protocols and procedures in the hatcheries if monitored regularly can assure they supply clean day old chicks free from bacterial and viral agents that may emanate from hatcheries.	<b>.672</b>	-.418
3. K13: Separately brooding indigenous chicks (chicks alone or chicks together with mother hen) for at least three weeks of their life ensures their adaptability to their new environment.	<b>.604</b>	-.404
4. K33: Supplementary feed are given in the shade that precludes wild bird getting attracted to it and getting closer to the domestic birds.	<b>.596</b>	-.328
5. K02: There are adequate feeding troughs and watering equipment for all birds in the poultry house.	.435	-.405
6. K01: A poultry house separate from the main house is provided for flocks.	.352	<b>-.702</b>
7. K34: Poultry houses facilitate parasite and disease control. They promote faster growth and protect the chicken from predatory birds and animals and adverse weather conditions and theft during the night as well as during the day time.	.476	<b>-.690</b>
8. K04: Training in good husbandry practices for all poultry farmers can improve biosecurity measures markedly.	.449	<b>-.685</b>
Reliability Alpha ( $\alpha = .789, N = 7$ )	.749	.729
Factor Inter-Correlation		
Factor 1	1.000	
Factor 2	-.590	1.000
Percentage Variance Explained (VE=42.730%)	34.557%	7.730%

Factor loadings  $>.5$  are in boldface. Kaiser-Meyer-Olkin Measure of Sampling Adequacy = .836; Bartlett's Test of Sphericity,  $\chi^2 = 538.046, df = 28 (p = .000)$ . Extraction Method: Maximum Likelihood. Rotation Method: Oblimin with Kaiser Normalization. Source: Main survey data, 2013



Table 4 presents the result of principal component analysis (PCA) of media seen read and heard variable (MSRH). PCA was performed because it was able to take a fairly large set of variables and reduce them to a smaller, more manageable number while retaining as much of the original variance as possible (Conway and Huffcutt, 2003). MSRH had 11 items. Therefore PCA was the most suitable tool to reduce these items and generate factor scores. A 1-factor solution was extracted from the MSRH

variable. The factor was reliable at  $\alpha = .814 > .700$  and explained  $VE = 35.333\%$  variance. Component loadings were  $> .500$  for all items. Therefore, all items in the MSRH variable were positively correlated to the extracted component, meaning that the extracted component reflected the suitability of MSRH.

**Table 4. Media Seen Read and Heard Component Matrix<sup>a</sup>**

	<b>Component 1</b>
Product placements	<b>.705</b>
Bill boards	<b>.694</b>
Branded logos	<b>.642</b>
Magazines	<b>.586</b>
Internet	<b>.581</b>
Soicial media	<b>.581</b>
Television	<b>.567</b>
Radio	<b>.557</b>
Word of mouth	<b>.551</b>
Mail	<b>.528</b>
Newspaper	<b>.513</b>
Reliability Alpha	.814
Percentage Variance Explained	35.333%
Kaiser-Meyer-Olkin Measure of Sampling Adequacy.	.837
Bartlett's Test of Sphericity $\chi^2 = 727.014, df = 55 (p = .000 < .050)$	

Factor loadings  $> .40$  are in boldface. Extraction Method: Principal Component Analysis. a. 1 components extracted. Source: Main survey data, 2013

### Binary Logistic Regression Results

Table 5 indicates that the full model predicted **79.7%** cases correctly. The omnibus test of coefficients  $\chi^2 = 96.115, df = 12 (p = .000 < .050)$  indicated the full model predicted intention to consume indigenous chicken significantly better than the null model. Examining the model's -2Log Likelihood  $-2LL = 225.074$  found it to lower than when the constant only  $-2LL = 321.189$  was estimated, meaning the model predicted the outcome

variable more accurately (Field, 2005). Nagelkerke  $R - Square = .453$  indicated a greater improvement from null model to fitted model. The goodness-of-fit was achieved by Hosmer and Lemeshow (H-L) Test,  $\chi^2 = 14.094, df = 8 (p = .079 > .050)$  which tested the null hypothesis that the observed data were significantly different from the predicted values from the model (Hosmer and Lemeshow, 2000). The test resulted in an insignificant chi-square indicating a good fit. Moreover, both variable coefficients and their corresponding

standard errors were small except for cultural inclination meaning there were no numerical problems with the model. Equation 7 with *p*-statistic values (in parentheses) presents the

full model. The full model was an improvement of the null model and predicted the intention to consume indigenous chicken.

$$\hat{Y} = -22.367_{(.997)} + 0.184_{(.389)}Income + 0.391_{(.194)}Age - 0.191_{(.470)}TEA - 0.0223_{(.945)}Gender + 1.002_{(.040)}Occupation - 0.241_{(.174)}Residence + 0.613_{(.022)}PBBP + 0.099_{(.717)}PCBP + 0.009_{(.917)}PLoc + 21.621_{(.997)}CIncl - 0.011_{(.948)}MSRH + 0.753_{(.111)}MaritalStatus. \quad (7)$$

**Table 5: Binary Logistic Regression for Intention to Consume Indigenous Chicken** (Dependent variable: Yes=1, No=0)

		B	S.E.	Wald	df	Sig.	Exp(B)	95% C.I. for EXP(B)	
								Lower	Upper
Step 1 <sup>a</sup>	Income	.184	.213	.741	1	.389	1.202	.791	1.826
	Age	.371	.286	1.687	1	.194	1.450	.828	2.539
	TEA	-.191	.264	.523	1	.470	.826	.493	1.386
	Gender	-.023	.336	.005	1	.945	.977	.506	1.889
	Occupation	1.002	.487	4.231	1	.040	2.725	1.048	7.082
	Residence	-.241	.178	1.851	1	.174	.785	.555	1.112
	PBBP	.613	.268	5.219	1	.022	1.846	1.091	3.123
	PCBP	.099	.274	.131	1	.717	1.104	.645	1.890
	PLoc	.009	.087	.011	1	.917	1.009	.851	1.196
	CIncl	21.621	6340.134	.000	1	.997	2.453E9	.000	.
	MSRH	-.011	.167	.004	1	.948	.989	.713	1.371
	MaritalStaus	.753	.472	2.543	1	.111	2.124	.842	5.359
	Constant	-22.367	6340.134	.000	1	.997	.000		
Model summary	-2 Log likelihood	225.07							
		4 <sup>b</sup>							
	Cox & Snell R Square	.339							
	Nagelkerke R Square	.453							
Hosmer and Lemeshow Test		$\chi^2 = 14.094, df = 8 (p = .079 > .050)$							
Omnibus Tests of Model Coefficients		$\chi^2 = 96.115, df = 12 (p = .000 < .050)$							
(step=block=model)									
Percentage correct predicted		79.7 %							

a. Variable(s) entered on step 1: Income, Age, Tea, Gender, Occupation, Residence, PBBP, PCBP, PLoc, CIncl, MSRH, Marital Status.

b. Estimation terminated at iteration number 20 because maximum iterations has been reached. Final solution cannot be found. Source: Main survey data, 2013

A binary logistic regression analysis was conducted to predict intention to consume indigenous chicken for 232 consumers in Kisumu City using income, age, terminal education age, gender, occupation, residence, perceived benefits of biosecurity principles, perceived concerns of biosecurity principles, purchase location, cultural inclination, media seen read and heard, and marital status as predictor variables and fitted into Equation 7 model. A test of the full model against a constant only model was statistically significant, indicating that the predictors as a set reliably distinguished between those intending and those not intending to consume indigenous chicken during the week following the interview chi square = 96.115,  $p < .000$  with  $df = 12$ ).

Nagelkerke's  $R^2 = .453$  indicated a greater improvement from the null model in predicting the relationship between prediction and grouping. Prediction success overall was 79.7% for intention to consume.

The Wald criterion demonstrated that only occupation ( $p = .040$ ) and perceived benefits of biosecurity principles (PBBP) ( $p = .022$ ) made a significant contribution to prediction. The rest of the variables were not significant predictors.  $Exp(B)$  values indicated that when occupation was raised by one unit (being employed) the odds ratio was 2.725 times as large and therefore consumers would be 2.725 more times likely to consume indigenous chicken. At the same time when PBBP factor score was increased by one unit (beneficial valuation of biosecurity principles for indigenous chicken) the odds ratio was 1.846 times as large and therefore consumers would be 1.846 more times likely to consume indigenous chicken.

Therefore, the null hypothesis ' $H_0$ : There are no significant preferences for indigenous chicken in Kisumu City' was consequently rejected and the alternative hypothesis ' $H_1$ :

There are significant preferences for indigenous chicken in Kisumu City' accepted.

## Discussion

The finding that gender, age and income were not significant predictors of intention to consume indigenous chicken was consistent with Huang *et al.* (2014) who found that gender, age, family monthly income were not significant predictors of intention to take precautions by avoiding the consumption of broiler chicken meat and products in their study in Malaysia. The finding on suitability of media seen read and heard (MSRH) in communicating indigenous chicken biosecurity as an insignificant predictor of intention to consume indigenous chicken was consistent with Huang *et al.* (2014) who found attention towards bird flu news not significant in predicting this intention to take precautions by avoiding the consumption of broiler chicken meat and products. News on bird flu had substantially reduced in Malaysian media. Similarly, Kenyan media did not feature any messages on indigenous chicken biosecurity during the study period 2011-2014 to enable respondents connect MSRH to intentions to consume indigenous chicken.

The binary logistic result was however inconsistent with Antwi-Boateng *et al.* (2013) study in Ghana who found that gender, age, family income levels religion, region, personality type and year in school affected the attitude towards poultry and pork meat consumption. In light of this, the study's finding was a new contribution to knowledge. In other words, these variables should be examined further to find out their true influence on the predictor variable.

Both gender and residence were also inconsistent with Caracciolo *et al.*, (2011), both in direction and significance. They found that willingness to enter the market of products related to the use of modern technologies was positively dependent on: female gender ( $p = .050$ ) and residence on

the large urban area of Naples ( $p = .050$ ) therefore inconsistent with the finding in Kisumu City, Kenya. Contrary to the reported finding on perceived concerns of biosecurity principles for indigenous chicken (PCBP), Caracciolo *et al.*, (2011) found that their factor named risk was significant in predicting willingness to enter the market both in direction and significance. PCBP was a factor score of a new construct to measure consumer attitudes on biosecurity principles for indigenous chicken. However, the finding on perceived benefits of biosecurity principles, though consistent with Caracciolo *et al.*, (2011), factor named usefulness of technologies in terms of significance, was in the opposite direction. Similarly, PBBP was a factor score of the new construct. Nicol and Davies (2013) moreover indicated that the major benefit of improving animal welfare was consumer acceptance, access to markets and employment. For instance, the nutritional benefit of free-range chicken meat compared to other meats was undeniable (Farrel, 2013). Therefore, as the logistic results indicated, PBBP significantly predicted the likelihood of intention to consume indigenous chicken. This was a new contribution to knowledge that was unknown prior to this research.

Occupation significantly predicted intention to consume indigenous chicken consistent with USAID (2010), who postulated an increase in demand for poultry products due to growth in population, urbanization and increase in per capita income for the middle class. The increase in per capita income was as a result of increase in employment opportunities for the middle class. For instance, more women in this category tended to get employed. Expanded higher education exposed individuals to more or new skills therefore increasing their employability while devolved governments and regional integration recently created new job opportunities. Employment tended to increase personal or household income, thereby increasing the opportunity to buy and or consume poultry products. This

confirmed the assertion by GoK (2009) that urbanization, increasing population and income growth due to employment were boosting the demand for food of animal origin at an unprecedented level. Therefore, variable named occupation rightly moderated consumer preference elicitation by availing and increasing income especially through employment, consequently permitting the individual to choose indigenous chicken. This finding had further Marketing implications: the respondents being students, an increase in employment after matriculation increased the likelihood of consuming indigenous chicken.

Cultural inclination was positively correlated to intentions to consume indigenous chicken. The relationship was however insignificant ( $p > .050$ ). The direction of its contribution was consistent with Muthiani *et al.* (2011), who found that religious festivals (an aspect of culture) periodically shifted local demand and prices of poultry. It was further consistent with Sonaiya and Swan (2004), Njenga (2005) and Kimani *et al.*, (2006) who indicated that cultural factors such as ceremonial and traditional aspects, traditional taste values and choice of carcass parts and organ meats influenced consumption of indigenous chicken. Therefore cultural inclination prediction of intention to consume indigenous chicken, though insignificant, was consistent with known studies.

## Conclusion

From the foregoing result and discussion, the mediating role of biosecurity principles of the link between consumer attitudes and consumer preferences was established through the variable perceived benefits of biosecurity principles (PBBP). PBBP was extracted from a new measure constructed based on Fishbein Multi-Attribute Model (Fishbein and Ajzen, 2010). The variable PBBP therefore first permitted a connection between consumer attitudes and biosecurity principles and thereafter mediated the relationship between consumer attitudes and

consumer presences. In the same vein, the moderating effect of consumer characteristics on consumer preference elicitation was established through the variable named occupation. Occupation was a control variable that significantly ( $p < .050$ )

moderated the relationship between consumer attitudes and consumer preferences. That is, being employed increased the likelihood of consuming indigenous chicken in Kisumu City.

The fitted empirical model (Equation 7) is an improvement of the null model as Table 5 indicates. Its -2Log Likelihood was lower than the intercept only model. Nagelkerke *R squared* = .453 indicated the model as an

improvement of the null model. The model had a good fit because its Hosmer-Lemeshow test is insignificant ( $p > .050$ ). It

predicted 79.7% cases correctly. The model therefore uniquely established the link between consumer attitudes and consumer preferences mediated by biosecurity principles and moderated by consumer characteristics. This is a major contribution of this research, because to the researcher's best knowledge, no previous research had taken this approach. Consequently, perceived benefits of biosecurity principles and occupation significantly predict consumer preferences for indigenous chicken in Kisumu City, Kenya.

### Recommendations

The study recommends using the fitted model in predicting consumers' intentions to consume indigenous chicken in Kisumu City. The model uniquely reveals that the link between consumer attitudes and consumer preferences is mediated by biosecurity principles and moderated by consumer characteristics. Therefore, marketers, consumer behaviorists, agriculturists, economists and policy decision makers might find the model suitable in predicting intentions to consume indigenous chicken in Kisumu City. By manipulating the explanatory variables,

interested parties might simulate the outcome variable and assess the model's efficacy in real life situations. The overall research finding in this study might be a valuable input to policy development related to food safety in poultry. This ground breaking work on indigenous chicken biosecurity is further recommended for future scrutiny and review especially by post-graduate teachers and students in the fields of Marketing, Consumer Behaviour, Economics and Agriculture to assess its value as a teaching aid and a reference or resource material.

### References

- Antwi-Boateng, C., Owusu-Prempeh, V., and Asuamah, S. Y.** (2013). Assessment of factors influencing the consumption of pork and poultry meat in Ghana: A comparative study. *International Journal of Innovative Research in Management*, 2(4), 1-12.
- Armstrong, G., and Kotler, P.** (2005). *Marketing: An Introduction, 7<sup>th</sup> Ed.* Upper Saddle River, N.J. Prentice Hall.
- Beckman, D. S. A., and Vanrompay, D. C. G.** (2009). Zoonotic *Chlamydophila psittaci* infections from a clinical perspective, *Clinical Microbiology and Infection*, 15(1), 11-17.
- Bett, H. K., Bett, R. C., Peters, K. J., Kahi, A. K., and Bokelmann, W.** (2012). Linking utilisation and conservation of indigenous chicken genetic resources to value chains. *J Anim Prod Adv*, 2(1), 33-51.
- Bett, H., Peters, K., Nwankwo, U., and Bokelmann, W.** (2011). Estimating consumer preferences and willingness to pay for the underutilised indigenous chicken products. *Tropentag*, October 5-7, 2011, Bonn accessed from <http://www.tropentag.de> on 2/6/12.
- Bird Life International** (2013). *East Asia/East Africa Flyway*. Retrieved on 22 February 2013 from <http://www.birdlife.org/datazone/userfil>

[es/file/sowb/flyways/6 East Asia East Africa Factsheet.pdf](#).

- Caracciolo, F., Coppola, A., and Verneau, F.** (2011). *Validation of a psychometric scale to measure consumers' fears of modern food technologies*. International European Forum on System Dynamics and Innovation in Food Networks, International European Forum, February 14-18, 2011, Innsbruck-Igls, Austria, pp160-174. [Accessed on 1 April 2012] <http://purl.umn.edu/122005>.
- Conway, J. M., and Huffcutt, A. I.** (2003). A review and evaluation of exploratory factor analysis practices in organizational research. *Organizational Research Methods*, 6(2), 147-168.
- Costello, A. B., and Osborne, J. W.** (2005). Best practices in exploratory factor analysis: Four recommendations for getting the most from your analysis. *Practical Assessment Research and Evaluation*, 10(7), 1-8.
- Creswell, J. W.** (2014). *Research design: Qualitative, quantitative, and mixed methods approaches* 4<sup>th</sup> ed. London: Sage Publications, Inc.
- de Vaus, D. A.** (2013). *Surveys in social research*. (5<sup>th</sup> ed.). London: Routledge.
- Fabrigar, L. R., Wegener, D. T., MacCallum, R. C, Strahan, E. J.** (1999). Evaluating the use of exploratory factor analysis in psychological research. *Psychological Methods*, 4(3), 272-299.
- Farrel, D.** (2013). The nutritional benefits of chicken meat compared to other meats. *Poultry Development Review*. Rome: Food and Agriculture Organization of the United Nations, p. 4. Retrieved March, 15, 2014 from: <http://www.fao.org/docrep/019/i3531e/i3531e.pdf>
- Field, A.** (2005). *Discovering statistics using SPSS*, 2<sup>nd</sup> ed. London: Sage Publications.
- Fishbein, M., and Ajzen, I.** (2010). *Predicting and changing behavior: The reasoned action approach*. New York: Psychology Press (Taylor and Francis).
- GoK** (2009). *Agricultural sector development strategy 2009-2020*. Nairobi: Government Printers.
- Hair, J. F. Jr., Black, W. C., Babin, B. J., and Anderson, R. E.** (2010). *Multivariate data analysis: A global perspective*, 7th Ed. Upper Saddle River, NJ: Pearson.
- Hosmer, D. W., Jr., and Lemeshow, S.** (2000). *Applied Logistic Regression*. New York: John Wiley and Sons.
- Hoyer, W. D., MacInnis, D. J., and Pieters, R.** (2012). *Consumer behaviour*. (6<sup>th</sup> ed.). Mason: Cengage Learning.
- Huang, L. C., Goh, Y. N., and Mohaidin, Z.** (2014). Factors influencing consumer intentions to avoid broiler chicken meat and products in Malaysia. *International Food Research Journal*, 21(1), 181-188.
- Institute of Grocery Distribution, IGD** (2007). *Consumer Attitudes to Animal Welfare*. A Report for Freedom Food by Institute of Grocery Distribution. Retrieved March 13, 2014, from <http://www.rspca.org.uk/servlet/Satellite%3Fblobcol%3Durlblob%26blobheader%3Dapplication%25>
- Jacques, K.A.** (2006). Zoonotic disease: not just from birds, and not just in the flu. In T.P. Lyons, K.A. Jacques and J.M. Hower, eds. *Nutritional biotechnology in the feed and food industries: Proceedings of Alltech's 22nd Annual Symposium, Lexington, Kentucky, USA*. 23-26 April 2006, pp. 149-159. Nottingham University Press, UK.
- Kagira, J. M., and Kanyari, P. W. N.** (2010). Questionnaire survey on urban and peri-urban livestock farming practices in Kisumu municipality, Kenya. *Journal of the South African Veterinary Association*, 81(2), 82-86.
- KAPP** (2013). *Kenya Agricultural Productivity and Agribusiness Project (KAPAP)*. Accessed on 28 January 2013 from <http://www.kapp.go.ke/index.php/other-projects/kapap/kapap-components>.
- Kim, R. B.** (2009). Factors influencing Chinese consumer behavior when buying

- innovative food products. *Agric. Econ. – Czech*, 55(9), 436–445.
- Kimani, T., Obwayo M., and Muthui, L.** (2006). *Avian flu threat: Socio-economic assessment of the impacts on poultry-related livelihoods in selected districts in Kenya*. Pan-African Program for the Control of Epizoonotics (PACE), Nairobi.
- Kotler, P.** (2010). *Principles of marketing: A South Asian perspective*, 13<sup>th</sup> ed. New Delhi: Pearson Education India/Prentice Hall.
- Larsen, N.** (2010). *Market segmentation: A framework for determining the right target customers*. An unpublished BA thesis, Aarhus School of Business. Retrieved March 13, 2014, from <http://pure.au.dk/portal/files/11462/BA.pdf>
- Lehner, A., Schneck, C., Feierl, G., Plees, P., Deutz, A., Brandl, E. and Wagner, M.** (2000). Epidemiologic application of pulsed-field gel electrophoresis to an outbreak of *Campylobacter jejuni* in an Australian youth centre. *Epidemiol. Infect.* 125, 13-16.
- Maddala, G. S.** (2008). *Introduction to econometrics*, 3<sup>rd</sup> ed. Delhi: John Wiley and Sons (Asia) Pte Ltd.
- Malhotra, N. K.** (2011). Personal reflections of my research contributions to marketing in Malhotra, N. K. (eds). *Review of Marketing Research: Special Issue-Marketing Legends*. Bingley: Emerald Group Publishing Ltd.
- Muriithi, D. K., Kihoro J., and Waititu, A.** (2012). Ordinal logistic regression versus multiple binary logistic regression model for predicting student loan allocation, *JAGST*, 14(1), 190-203.
- Muthiani, E. N., Kirwa, E. C., and Ndathi, A. J. N.** (2011). Status of chicken consumption and marketing among the Maasai of Kajiado District, Kenya. *Livestock Research for Rural Development*, 23(158). Retrieved May 25, 2014, from <http://www.lrrd.org/lrrd23/7/muth23158.htm>
- Nagelkerke, N. J. D.** (1991). A Note on a General Definition of the Coefficient of Determination. *Biometrika*, 78, 691–692.
- Ndirangu, L., Birol, E., Roy, D., and Yakhshilikov, Y.** (2009). *The Role of Poultry in Kenyan Livelihoods and the Ex Ante Impact Assessment of HPAI on Livelihood Outcomes*. HPAI Research Brief | No. 11 – Year: 2009: Controlling Avian Flu and Protecting People’s Livelihoods in Africa and Indonesia.
- Nicol, C. J., and Davies, A.** (2013). Poultry welfare in developing countries. *Poultry Development Review*. Rome: Food and Agriculture Organization of the United Nations. p. 110-113. Retrieved March, 15, 2014 from: <http://www.fao.org/docrep/019/i3531e/i3531e.pdf>
- Njenga, S. K.** (2005). *Productivity and Social – Cultural Aspects of Local Poultry Phenotypes in Coastal Kenya*. MSc Thesis, Danish Institute of Agricultural Sciences, Research Centre, Foulum.
- Nyaga, P. N.** (2007a). *The structure, marketing and importance of the commercial and village poultry industry: An analysis of the poultry sector in Kenya*. Rome: Food and Agriculture Organization (FAO) of the United Nations.
- Omiti, J. O., and Okuthe, S. O.** (2008). *An overview of the poultry sector and status of highly pathogenic avian influenza (HPAI) in Kenya — Background Paper*. Collaborative research on pro-poor HPAI risk reduction, Africa/Indonesia Team Working Paper No. 4, Washington, DC, USA.
- Onim, M.** (2002). *Final report of scoping study for urban and peri-urban livestock keepers in Kisumu City, Kenya*. Lowland Agricultural and Technical Services Limited (Lagrotech), Kisumu, Kenya.
- Osano, O. and Arimi, S.** (1999). Retail poultry and beef as sources of *Campylobacter jejuni*. *East Afri. Med. J.*, 76, 141-143.
- Padungton, P., and Kaneene, J. B.** (2003). *Campylobacter spp.* in human, chickens,

- pigs and their antimicrobial resistance. *J. Vet. Med. Sci.*, 65, 161-170.
- Pilotta, J. J., Schultz, D. E., Drenik, G. and Rist, P.** (2004). Simultaneous media usage: A critical consumer orientation to media planning. *Journal of Consumer Behaviour*, 3(3), 285–292.
- Pindyck, R. S., and Rubinfeld, D. L.** (2000). *Econometric models and economic forecasts*. (4<sup>th</sup> ed.). New York: McGraw Hill Inc.
- Saunders, M., Lewis, P., and Thornhill, A.** (2012). *Research methods for business students*. (3<sup>rd</sup> ed.) London: Prentice Hall-Financial Times.
- Schiffman, L. G., and Kanuk, L. L.** (2009). *Consumer behaviour*, 10<sup>th</sup> ed. Boston: Prentice Hall.
- Sonaiya, E. B., and Swan, S. E. J.** (2004). *Small-scale poultry production: Technical guide*. FAO Animal Production and Health. Rome: Food and Agriculture Organization of the United Nations.
- Storey, M., and French, S.** (2004). Food advertising and marketing directed at children and adolescents in the US. *International Journal of Behavioral Nutrition and Physical Activity*, 1, 3.
- Tashakkori, A. and Teddlie, C.** (2010). *SAGE handbook of mixed methods in social and behavioral research*. (2<sup>nd</sup> ed.). London: SAGE Publications, Inc.
- Trochim, W. M.** (2006). The research methods knowledge base. (2<sup>nd</sup> ed.). Internet WWW page, at URL: <<http://www.socialresearchmethods.net/kb/>> (version current as of October 20, 2006).
- USAID** (2010). *Partnership for Safe Poultry in Kenya (PSPK) program: Regional poultry value chain analysis*. Nairobi: United States Agency for International Development.
- Vagias, W. M.** (2006). *Likert-type scale response anchors*. Clemson International Institute for Tourism and Research Development, Department of Parks, Recreation and Tourism Management. Clemson University.
- Wells, D. W.** (2014). *Measuring advertising effectiveness*. New York: Psychology Press.
- Wyer Jr., R. S., and Srull, T. K.** (2014). *Handbook of social cognition, volume 1: Basic processes*. (2<sup>nd</sup> ed.). New York: Psychology Press.



# ***BASIC SCIENCES***

# Promoting Knowledge-based Economy for Sustainable Development for the 21<sup>st</sup> Century: an STS Perspective

By

**Arun Datta<sup>1</sup>**

*1; Centre for Science, Technology and Society Studies (STS), Technical University of Kenya*

---

## Abstract

For the purpose of this paper, knowledge is taken as scientific and technological. Science has contributed towards depletion of natural resources and will help us in restoring the same for sustainable development. Science provides the knowledge for technology but its aims and methods are not very clear. In the last about thirty years, the social aspects of science have been brought to light. Science and technology are for societies. The two have to fit. Culture, aspirations, strengths and weaknesses of the societies must be considered before bringing in technologies.

**Key words:** Sustainable development, Economy, STS Perspective

---

## Introduction

STS stands for Science, Technology and Society Studies. This is an interdisciplinary field that is creating an integrative understanding of history, philosophy and consequences of science and technology. STS scholars study, how science and technology influence, and are in turn influenced by society.

For the purpose of this paper, “knowledge”, is taken as scientific and technological. We will discuss the promotion of science and technology for sustainable development. Michael Thomas Needham, an educator defines “Sustainable Development”, as ‘the ability to meet the needs of the present while contributing to the future generation’s needs’. Many of the world’s finite resources are being extracted at very fast pace. Even the renewable resources are being consumed so fast that they may not remain ‘renewable’

soon. For example the fish stocks, the rain forests, the natural habitat of many species (which forms the back-bone of Kenyan tourism).

The World Bank has put up a story on its web, “worldbank.org” on the 5<sup>th</sup> of June 2014 titled “Measuring Wealth to Track Sustainability”. It says that although most countries show growth, many of them are depleting their wealth. Wealth includes minerals and energy, agricultural land and forests. It sounds logical, in such a situation to turn to science for an economy which is sustainable. It is science which contributed towards depletion of many of natural resources and again it is science that we are turning to, for remedies. Let us try to understand this thing called science.

## Science: A Philosophic View

Science provides the knowledge which is translated into the “know-how” or

technology. Science itself is a complex and historically embedded activity. Scholars disagree about the goals of science. To start with, opinions differ over the activities of the scientists. Kitcher (1993) is of the opinion that the scientists aim for approximate truths, because Truth is beyond humans' reach. Giere (1999) argues that scientists aim to produce representations of the world because the "real" world may not be known. Bas Van Fraassen (1980) writes that scientists merely attempt to make good predictions. Steve Fuller (1993) talks of different epistemic goals espoused by the scientific community. He feels that these goals need to be debated democratically to establish a 'science policy'.

Lynn Nelson (1990) writes that the epistemic goals are achieved socially and that these cannot be distinguished from non-epistemic values. Observations and values are interwoven and socially-dependent. These are not fixed or universal. She argues that knowledge is community-based and not individual.

On the extreme end is the argument that knowledge is constructed rather than discovered by societies. It is during the 1970s and 1980s that such social constructivism guided the work in sociology of science. However, recent work in the interdisciplinary field of Science, Technology and Society studies takes a less radical view of scientific knowledge. It takes scientific knowledge as a result of inputs from both the social and material sources.

Laudan and Laudan (1979) and also Thomas Kuhn (1977) argue that different scientists apply scientific method differently. Value traits such as simplicity, consistency, scope, explanatory power and predictive power are assigned different weights. The same holds for technology, which is the application of science. It follows that diversity of race, class and gender is good in the population of scientists. It increases the variety of creative ideas.

Scientific knowledge is not beyond controversies and can bring about political divides. Sarewix (2004) writes that science supplies contesting parties with relevant but different facts about nature. Secondly, competing disciplinary approaches of a controversy may be tied up to competing political or ethical positions.

From the above discussion, it is clear that science and therefore technology are not neutral. Even if we do not subscribe to any particular view, we are convinced that both creation and application of scientific knowledge has social influences. **If we wish to promote technology-driven economy, we must understand those influences and "domesticate" and mould that technology to our societies' needs to avoid rejection or harm to our communities.**

#### **Knowledge-Based Economies: Some Points to Ponder**

Technology has some socio-cultural perspectives attached with it. These can be divided as indigenous (tradition and community driven) and western (scientifically driven and from the developed world). As the names suggest, the two may not be conducive to each other. A new technology may challenge local traditions. Srinivasa (2004) gives the example of a manual treadle pump, named Kick-Start which helps communities in accessing clean water easily. Its initial design caused women to move their hips to move in a provocative manner. Therefore, many communities rejected it. Later, with indigenous knowledge and perspective, the pedal of the pump was re-designed to accommodate the communities' cultural norms. An organization, named Sustainable Health Enterprises, in Uganda, used indigenous knowledge to make sanitary pads for young women, thus reducing their 'drop-out' rates. Development and better quality of life are paramount however technology should not force a community to forgo its identity, which it wishes to preserve.

Local manufacturing for local markets, with local raw materials seems the best option for communities. However, outsourcing sometimes may be more economically sustainable. All developmental goals cannot be achieved at the same time. Importation means fewer jobs locally, on the other hand, local raw materials may not be the best in terms of quality. A broader view needs to be taken. For example, cell phones are neither designed nor manufactured in Africa. However, thousands of repair-technicians, shops, and M-pesa businesses have emerged. So many people earn a living, because of cell phones.

Level of community involvement in technological projects can pose challenges. For example, a large greenhouse is economical if many people share the cost and benefits. How to allocate space to different shareholders, to their satisfaction? Who harvests the crop? And there are the challenges of maintenance and pilferages. Expensive technologies need organization of many households to work in harmony.

There can be conflicts of interest. For example, a technological enterprise that provides communities with safe drinking water at low cost is beneficial to many. However, it sends bottled water companies or water vendors out of business. Technologies affect different people in different ways. It is the communities who can decide, what tool to use and how.

Western industrial revolutions have shown that technologies lead to lower employment, at least for certain periods. Some communities may benefit from mass automation in some situations. Overall, a choice needs to be made between providing employment and mechanization.

#### ***An example of local technology and innovation***

Pastoralists have often been blamed for environmental degradation because it is normally believed that their animals overgraze. Recent scientific evidence shows that pastoralism was an African innovation. In his book, *Living with Uncertainty*, Ian

Scoones writes that pastoralism is viable and is ideal for dry-lands. He says that innovations have led to brokering of drought response strategies across communities. New technologies such as dams with plastic coatings at the bottom are being deployed. Mobile phones are used for looking for grazing and surveillance.

#### **Conclusion**

The knowledge provided by science can drive the economies in the 21<sup>st</sup> century. Yes, we should promote it. However, we should be aware of the possible pitfalls. To start with, science itself is not a neutral enterprise, it is the result of human endeavors and prone to errors. It has social inputs and implications. Societies are not the same. The society whose economic conditions we intend to improve should be involved in deciding the technology intended for it. Sometimes the age-old practices can be optimized with a little help of new technologies.

#### **References**

- Fuller, S.** (1993). *Philosophy of Science and its Discontents*. 2<sup>nd</sup>ed. New York: The Guilford Press.
- Giere, R.** (1999). *Science Without Laws*. Chicago: University of Chicago Press.
- Kitcher, P.** (1993). *The Advancement of science*. Oxford and New York: Oxford University Press.
- Kuhn, T.** (1977). *The Essential Tension*. Chicago: University of Chicago Press.
- Laudan, R. and Laudan, L.** (1979). Dominance and Disunity of Method: Solving the problems of Innovation and Consensus, *Philosophy of Science* 56(2): 221-37.
- Nelson, L. H.** (1990) *Who Knows? From Quine to Feminist Empiricism*. Philadelphia: Temple University Press.
- Sarewitz, D.** (2004). How science makes environmental controversies worse, *Environmental Science & Policy* 7 (2004) 385-403.

- Srinivas, S. and Jalakashi, C.** (2004): Alternatives to Micro-Irrigation: Evaluation of a Treadle Pump” *Economics and Political Weekly*, vol. 39, no.38, 4271-75.
- Van Fraassen, B.** (1980). *The Scientific image*. New York: Oxford University Press.

## Reviewing the Case of Sustainable Management of Water Hyacinth in Lake Victoria, Kenya

By

C. M. Mutebi\*<sup>1</sup>, G. O. Opande<sup>2</sup>, P. F. Arama<sup>3</sup> and D. Buyela<sup>2</sup>

<sup>1</sup>Kenya Agricultural Research Institute, Kibos Center, P.O. Box 1490-40100, Kisumu,

<sup>2</sup>Department of Botany, Maseno University, Private Bag, Maseno, Kenya

<sup>3</sup>Department of Agriculture, Natural Resources and Environmental Studies, Rongo University College, Box 205, Rongo, Kenya.

\*Corresponding author: [cmutebi@yahoo.com](mailto:cmutebi@yahoo.com)

---

### Abstract

Water hyacinth is an invasive weed found in ponds, rivers and lakes. It has negative and hence disastrous impact on water resources. In combating the weed, there is need to employ methods that are sustainable and cost effective. Physical, biological and integrated control methods coupled with practices that ensure that domestic and agricultural waste do not flow into the water bodies' work well to lessen the weed load in vulnerable areas. This paper is a review of the interworking of these methods in as far as managing water hyacinth in Lake Victoria is concerned. It is possible to have a catalogue of cost effective, environmentally friendly and sustainable methods for overcoming the threat of water hyacinth against the water resources of Lake Victoria.

**Key words:** Control Methods, Lake Victoria, Sustainable, Water hyacinth.

---

### Introduction

The water hyacinth weed, with its characteristic thick fringes and floating mats, has had serious impact on many aspects of life around Lake Victoria (Tomaz, 2000). The weed is invasive and is found in ponds, rivers and lakes. Like all other invasive species, it is easily propagated asexually by root or stem fragments and rapidly matures. It is typically a prolific seed producer and has high seed germination rates. This makes it to be of immense economic importance (Pimentel *et al.*, 2000). It is an exotic species that have been accidentally transferred due to increased foreign travel. It can expend more energy on growth and reproduction

and perhaps aiding their invasive nature and hence, their economic importance (Pimentel, 2000; Hayes, 2002). Usually when an invasive plant enters a new habitat it does out-compete and displace native vegetation thereby becoming established. Some of the ways such displacements affect the native biota include a reduction in biodiversity, habitat and food and an overall change in ecological processes. Water hyacinth infestation leads to evapo-transpiration that increases up to 9.84 times (Kathiresan, 2005). The negative and hence disastrous impact of water hyacinth has been studied extensively thus confirming these processes (Msafiwa, 2001). According to United

Nations, water quality problems are attributed to eutrophication that enhances proliferation of water hyacinth plant (UNEP, 2008). This is evident in Winam Gulf in Kisumu a large arm of Lake Victoria that extends east into Kenya.

### **Sustainable hyacinth control methods**

Invasive weeds such as water hyacinth may be difficult or impossible to control or eliminate once they are established. Attempts to control adversely impact remnant native vegetation (Njuguna and Thitai, 1993). Water hyacinth infestation is seldom totally eradicated. Instead, it is a situation that must be continually managed (United Nations News, 2000; LVEMP, 2004). Elimination of water weeds is a costly process both in of fiscal and temporal terms (Mailu, 2001). A chemical control method pauses an environmental problem and renders the water unsuitable for human and livestock consumption.

Economic uses of water hyacinth can spur harvesting, that can reduce the weed load in the lake. Results of a baseline survey indicate that water hyacinth can be used as an organic fertilizer (VicRes, 2013). Other known economic uses are that have been reported include making of chairs and baskets, coffins, hats, bags, ropes and animal feeds.

### **Mitigating the negative impact of water hyacinth with sustainable methods**

Physical control of water hyacinth involves employing manual labour and mechanical harvesters to remove weeds. However, a major problem with this method is that plants fragmented by mechanical harvesting can re-grow from the fragments, promote weed re-establishment, and worsen the weed problem (Sidorkewicj *et al.*, 2000). Therefore, a finding economic use for the materials physically harvested will be sustainable. Various youth groups along the lake have found use for the harvested materials. To make physical removal sustainable, there is a need to ensure that the returns obtainable from the economic use of the water hyacinth

materials are harnessed and ploughed back to fund the physical control methods.

Water hyacinth thrives best in warm tropical environments whose waters are polluted. Loading of nitrogen (N) and phosphorus (P) in the water aids its growth. The growth rate is strongly dependent upon the concentration of dissolved N and P within its vicinity (Moorhead *et al.*, 1988; Debusk and Dierberg, 1989; Reddy *et al.*, 1989; 1999). Reddy and Tucker (1983) found that rates of N and P uptake were similar to one another and correlated directly with growth. According a report by UNEP eutrophication is a major component in enhancing the proliferation of water hyacinth in the Winam Gulf (UNEP 2008). East Africa's major watersheds that include rivers Nzoia, Yala, Sondu and Miriu empty into Lake Victoria's Winam Gulf. The Gulf, therefore, experiences an ecological disaster due to luxuriant growth of water hyacinth that is enhanced by increased nutrient flow. Water hyacinth growth is enhanced by the human activities. It proliferates more in closed waters than in open waters (Kling *et al.*, 2001). Given that there are no sewerage treatment lagoons within the areas surrounding of winam Gulf, the levels of raw human waste flowing into the lake from the surrounding towns are beyond the acceptable levels (Balirwa, 1998).

### **Biological Control Method**

Biological control method is the reduction of the density of the weed in its actively growing or dormant state by one or more organisms accomplished naturally or through manipulation of the environment. It can also be by mass introduction of one or more antagonists of the weed (Baker and Cook, 1974).

### **Biological Agent Control Methods**

Several fungal plant pathogens have been shown potential in controlling *E. crassipes* under experimental conditions (Nachtigal and Pitelli, 2000; Opande *et al.*, 2004; Mutebi *et al.*, 2013). A biological control method, leads to return on investment. This

is accomplished since the process is self-sustaining once it commences. It is environmentally friendly as no persistent residues are left behind. The capacity of a biological agent to establish in a new ecosystem and spread in the environment is the key advantage for a sustainable and recurrent pest control strategy. Classical biological control is of primary concern because it entails the release of exotic natural enemies with dispersal and permanent establishment as an objective. If successful, the introduction of exotic enemies leads to an irreversible situation. In contrast, the release of native biological control agents in augmentative biological control programs, either in large (inundative) or small (inoculative) numbers, is less likely to interfere with native flora or fauna over a long period of time. Biological control of water hyacinth using insect agents involves large-scale introduction of both *Neochetina bruchi* and *N. eichhorniae* weevils as recently reported in a case in Lake Victoria (Njoka, 2004). Fungal pathogens can also be used in the bio-control of water hyacinth. Some of these pathogens are: *Cercospora rodmanii* (Conway), *Acremonium zonatum* (Sawada) Gams, *Alternaria* sp and *Myrothecium roridum*.

### Biological Control Method at Maseno University

A study was conducted recently to find out the pathogenicity on water hyacinth formulations of *Acremonium zonatum* bio pathogen (Mutebi *et al.*, 2013). Therefore, in this study, Disease severity (DS) score was reported on a visual scale that lies between 0 and 9. Disease incidence (DI) was determined by counting the number of infected leaves on each plant and expressing the number as a percentage of inoculated leaves. DS and DI recordings were done at 0, 14, 28 and 42 days after inoculation. The values got were converted to area under disease progress stairs (AUDPS) based on a previously reported formula (Van der, 196 and improved 2012). The results revealed that the pathogen caused visible progressive disease infection on the leaves during the study period. In the analysis of variance (ANOVA) of the AUDPS for the four formulations, there were significant differences ( $0 < 0.05$ ) in the means. Corn oil exhibited the highest disease severity (DS) and disease incidence (DI) values of 1.9 and 25.6%, respectively and Tween 80 had the lowest at 1.5% (Table 1).

**Table 1: Mean DS and DI values for four oil formulations**

FORMULATION	MEANS	
	DS (Score)	DI (%)
Corn oil	1.9	25.6
Glycerol	1.5	19.9
Mineral oil	0.8	9.43
Tween 80	0.6	1.5
Sterile water	0.0	0.0

Table 1 shows the mean disease severity (DS) and disease incidence (DI) values for the four oil formulations.



**Table 2: Mean AUDPS values for severity (DS) score and percent disease incidence (DI) *Acromonium zonatum* in different oil emulsions on water hyacinth plants**

FORMULATION	MEANS	
	DS	DI
Corn oil	89.95A	977.0A
Glycerol	53.10AB	833.9A
Mineral oil	30.10B	428.4B
Tween 80	23.10B	394.3B
LSD	38.2	396.2

Means for DS and DI with the same letter are not significantly different ( $P < 0.05$ ).

From Table 2, Corn oil significant differences in AUDPS values for both DS and DI can be observed between the different oil formulations. Furthermore, it is observed that corn oil had the highest AUDPS values for DS and DI at 89.95 and 977.0, respectively. Tween 80 had the lowest DS and DI values at 23.10 and 396.2, respectively.

### **Integrated Control**

Attempts have been made to develop an indigenous fungal pathogen as a bioherbicide that can work concurrently with the insect agents to enhance the levels of biological control (Den Breeÿen, 2000; Bateman, 2001). A combination of biological and chemical control in an early state of infestation and a well-coordinated flow of expertise and resources is likely to be the best long-term solution to the water hyacinth problem (Navarro and Phiri, 2000).

### **Challenges faced in applying contemporary control measures**

In many tropical and subtropical regions, the weed grows at rates that far outstrip control abilities of existing biological agents. It can grow up to a meter or so in height and can double its biomass in 6 days. Physical control has therefore got to be intensive and regular and is thus ultimately expensive. The cost of clearing a hectare of weed in the 1990s was estimated to be between US \$ 2400 and 30000 (Haller, 1996). Farri and Boroffice (1999) when considering physical control in Nigeria considered it to be too costly (US \$ 5000 ha<sup>-1</sup>). In addition, a major problem is that plants fragmented by mechanical harvesting can re grow from the fragments, promote weed reestablishment, and worsen the weed problem (Sidorkewicj

*et al.*, 2000). In biological control by insects, low survival rate of only 20% of the insect from egg to adult makes this method, on its own, to be ineffective (Njoka, 2004).

There are certain economic disadvantages in the use of bio control products. Damage to non-target native flora and fauna occasionally occurs. There is also indirect damage to the environment in that once the target weed is destroyed, a new one may emerge and pose a worse problem than there was done by the destroyed weed. The bio control pesticides are limited in economic use in that they cannot stand competition from chemical agents. The applicator for bio agents is more costly than for chemical pesticides. Patenting of bio pesticides is more difficult than it is for chemical herbicides.

The greatest economic handicap of most biological control agents is their specificity. Too often, they target only a single or a few related pathogens. This means that the range of application is extremely narrow without sufficient promise to cause a rush of investors.

Reduction in the abundance of pests may leave empty niches that can be occupied by other noxious species. For example, destruction of stands of major weeds may

leave bare surfaces which could be colonized by another weed (Harris, 1990). The case of hippo grass growing in areas formerly infested with water hyacinth is a good example.

### **Overcoming the challenges**

Proliferation of water hyacinth can be stopped effectively by employing strong preventive measures. These measures entail capping the flow of domestic and farm waste into the water bodies by using all the available methods. There is also a need to sensitize people on the adverse effect caused by moving hyacinth material that may find its way to ponds and other water bodies and sprout there. Early identification and institution of control measures is important (Wittenberg and Cook, 2001)

Known ecological impacts of weeds and control methods gathered from other regions should be taken into consideration in assessing the potential local impacts of control methods (Stocker, 2000). To supplement the insect bio control strategy, fungal agents have been tried. The bio control efficacy of the fungus should be somehow improved by adopting a mycoherbicidal approach. To be successful in this approach, the application of an inundative dose of inoculums at a particular susceptible stage of the weed reduces the lag period for inoculums build up and pathogen distribution that is essential for natural epiphytotics.

### **Conclusion**

It is possible to have a catalogue of cost effective, environmentally friendly and sustainable methods for overcoming the threat against the water resources of Lake Victoria and especially in Winam Gulf corridor that experiences heavy infestation due to its narrow and closed form.

### **Recommendation**

In order to protect the water surface of Lake Victoria from the ravages of water hyacinth, sustainable control methods have to be put in place to offset the huge investment in

terms of financial resources that would normally be involved. This has got to be joint endeavor between all the countries flanking Lake Victoria.

### **Acknowledgement**

We, the authors, would like to thank the Maseno University Workshop Organizing Committee for providing the forum for the discussion of the contents of this paper.

### **References**

- Balirwa, J. S.** (1998). Lake Victoria wetlands and the ecology of the Nile tilapia *Oreochromis niloticus* Linne. PhD thesis, Wageningen Agricultural University, 247.
- Debusk, T. A. and Dierberg F. E.** (1989). Effects of nutrient availability on water hyacinth standing crop and detritus deposition. *Hydrobiologia*, 174, 151-159.
- Den Breejen, A.** (2000). Biological control of water hyacinth in South Africa using plantpathogens. *Water Hyacinth News* 2, 3-7.
- Farri, T. A. and Boroffice, R. A.** (1999). An overview on the status and control of water hyacinth in Nigeria. In: "Proceedings of the first IOBC global working group meeting for the biological and integrated control of water hyacinth". Eds. Hill M.P., Julien M. H. and Center T.D. Weeds Research Division, ARC, South Africa, 182.
- Harris, P.** (1990). Environmental Impact Assessment of Introduced Biological Control Agents. In "Critical issues in Biological Control" (Ed. M. Mackaur, L. E. Ehker and J Roland), 289-300.
- Hayes, K. R.** (2002). Identifying hazards in complex ecological systems. Part 2: Infection modes and effects analysis for biological invasions. *Biological Invasions*, 4, 251-261.
- Kathiresan, R. M.** (2005). Allelopathy for biocontrol of water hyacinth. Fourth World Congress on Allelopathy. The Regional Institute Limited.

- Kling, H. J., Mugidde, R. and Hecky, R. E.** (2001). Recent changes in the phytoplankton community of Lake Victoria in response to eutrophication. In: "The Great Lakes of the World (GLOW): Food-web, Health and Integrity". Eds. Munawar M. and Hecky R.E. Backhuys, Netherlands, 47-65.
- LVEMP.** (2004). Lake Victoria Environmental Management Project Report. 31<sup>st</sup> August, 2004. World Bank.
- Mailu, A. M.** (2001). Preliminary assessment of the social, economic and environmental impact of water hyacinth in lake Victoria basin and status of control. In: Biological and integrated control of water hyacinth. ACIAR Proceedings No. 102.
- Mustafa, A. L., Velini (Eds).** (2000). Recent advances in biology and control of submersed aquatic weeds in Brazil. Abstracts of the Third International Weed Science Congress 3, 220.
- Masifwa, F. W., Twongo, T. and Denny, P.** (2001). The impact of water hyacinth, *Eichhornia crassipes* (Mart) Solms on the abundance and diversity of aquatic macroinvertebrates along the shores of northern Lake Victoria Uganda. *Hydrobiologia* 452, 79–88.
- Moorhead, K. K., Reddy F. R. and Graetz D. A.** (1988). Water hyacinth productivity and detritus accumulation. *Hydrobiologia*, 157, 179-185.
- Mutebi, C. M., Arama, P., Opande, G., Were, J., Omolo, P. and Buyela, D.** (2013). Innandative bio-control of water hyacinth using zonate leaf spot fungal agent. 11<sup>th</sup> African Crop Science Society Conference. 13<sup>th</sup> to 17<sup>th</sup> October, 2013, Entebbe, Uganda.
- Navarro, L. and Phiri, G.** (2000). Water hyacinth in Africa and the Middle East. A survey of proble/ms and solutions. – International Development Research Centre, Canada, 120.
- Njoka, S.W.** (2004). The biology and impact of *Nechoetina* weevils on Water Hyacinth *Eichhornia crassipes* in Lake Victoria Basin, Kenya. Ph.D Thesis, Moi University.
- Njuguna, S. G. and Thiai, G. N. W.** (1993). The control of floating water-weed infestations In Kenya. In: "Control of Africa's floating water weeds". Eds. Greathead A. and de Groot P.J. Commonwealth Science Council, Series no. CSC (93) AGR-18, Proceedings, 295:187.
- Opande, G. O., Onyango, J. C. and Wagai, S. O.** (2004). Lake Victoria: The water hyacinth (*Eichhornia crassipes* [MART.] SOLMS), its socio-economic effects, control measures and resurgence in the Winam Gulf. *Limnologica* 34, 1-2: 105-109.
- Pimentel, D., Lach, L. Zuniga, R. and Morrison, D.** (2000). Environmental and economics of non-indigenous species in USA. *Bioscience*. 53:53-65.
- Reddy, K. K. and Tucker, J.C.** (1983). Productivity and nutrient uptake of water hyacinth, *Eichhornia crassipes*. In: Effect of nitrogen source. *Economic Botany*, 37: 237-247.
- Reddy, K. K., Agami, M. and Tucker, J. C.** (1989). Influence of nitrogen supply rates on growth and nutrient storage by water hyacinth (*Eichhornia crassipes* (Mart.) Solms plants. *Aquatic Botany*, 36: 33-43.
- Sidorkewicj, N. S., Sabbatini, M. R. and Irigoyen, J. H.** (2000). The spread of *Myriophyllum elatinoides* Gaudich. and *M. aquaticum* (Vell.) Verdc. from stem fragments. Abstracts of the Third International Weed Science Congress 3: 224.
- Simko, I. and Piepho, H. P.** (2012). The Area Under Disease Progress Stairs: Calculation, Advantage and Application. *Phytopathology*. Volume 102:381.
- Stocker, R. K.** (2000). Why isn't alien ecological impact extrapolated geographically? Abstracts of the Third International Weed Science Congress 3: 222.
- Tomaz, S. M.** (2000). Aquatic macrophytes in Brazilian reservoirs: an ecological perspective. Abstracts of the Third

- International Weed Science Congress 3: 217.
- United Nations News Highlights.** (2000). "Fighting water weeds in West Africa." Food and Agriculture Organization of the United Nations. 16 Aug 2000. United Nations. 77.
- UNEP.** (2008). Africa: Atlas of our changing environment. Division of early warning and assessment. United Nations Environmental Program. Nairobi, Kenya.
- Van der P.** (1963). Plant Diseases. Epidemics and Control. Academic press, New York.
- VicRes.** (2013). Lake Victoria Research Initiative Newsletter, Volume 6 (2).

## Towards Macroeconomic Convergence and Monetary Coordination: Challenges to Regional Integration in Sub-Saharan Africa

By

Okech, S. O.\*<sup>1</sup>, Ngigi, M.<sup>2</sup>, Basweti, E.<sup>3</sup>, Kibet, N.<sup>1</sup> and Okeyo, B. O.<sup>4</sup>

<sup>1</sup>Department of Agricultural Sciences, Kisii University, P.O. Box 408 – 40200 Kisii, Kenya

<sup>2</sup>Department of Agricultural Economics and Agribusiness Management, Egerton University, P.O. Box 536- 20105, Egerton, Kenya

<sup>3</sup> Department of Agricultural Sciences, Kisii University, P.O. Box 408 – 40200, Kisii, Kenya

<sup>4</sup> Kenya Women Finance Trust Limited, P.O. Box 4179-00506, Nairobi, Kenya

\* Corresponding author e-mail: [silasokech@gmail.com](mailto:silasokech@gmail.com)

---

### Abstract

Regional integrations in Africa hold a long history of existence dating back to pre-independence; but few are on track to their second intended destinations- towards macroeconomic convergence and monetary coordination. This paper follows these long paths highlighting some distinguished achievements made to date and challenges to macroeconomic convergence achievement for African most successful economic blocs -East Africa Community (EAC) and South Africa Development Community (SADC). Findings indicate that some macroeconomic variables (inflationary targets) display a tendency of convergence across countries. On intra-regional trade, the flows are relatively low, but higher on average within some individual countries. Several recommendations made are contained in the study.

**Key words:** Regional integration, Africa, East Africa Community, South Africa Development Community, Variables.

---

### Introduction

Globally, regional integrations are considered as engines in the realization of sustainable economic growth. Nevertheless, in Sub Sahara Africa, sustainable economic growth is constrained by the small nature of economies, high inflation, and instability of exchange rates; financial fragility and the poor state of infrastructural services (Oyejide, 2000; Fielding and Shields, 2005). These constraints are responsible for the non-achievement of UNDP's Millennium Development Goals. Therefore, promoting

macroeconomic integration especially monetary union is not only a necessary condition now but an urgent agenda in Africa than anywhere around the world.

At present, there are numerous regional integration (UMA, ECCAS, ECOWAS, EAC, COMESA, SADC, IGAD and CEN-SAD) operations in Africa seeking to promote economic cooperation, intra-regional trade, socio-economic policy formulation and management of shared infrastructure among members. Some of

these current arrangements, however, are characterized by diversity in common currency unions like CFA franc zone based on French Franc, Common Monetary Area (CMA) based on South African Rand and free floating exchange rates of regional economic powers like South Africa. In addition, most of these blocs vary in range and variety of rules; functions, memberships and are in different stages of implementation. Some exhibit extensive range of product coverage, in the extent to which they address non-tariff barriers and in handling of contingent protection – antidumping actions and other functions partially or suffer from non-implementation crisis.

Empirical result further indicates a long history of existence of regional integrations in Africa dating back to pre-independent period, but few are on track to their second intended destinations- towards macroeconomic convergence and monetary coordination. Traditional ones like South African Customs Union (SACU) dates back to 1800 (Gibb, 1997) - with start stop characteristics, coupled with many obstacles and fewer achievements to count on and only being inspired by the success stories of European and American integrations.

Some of the benefits expected out of good working integrations include - promotion of regional solidarity; enhancement of trade bargaining power; access to markets and for economic survival in the phase of globalization (Debrun *et al.*, 2005). However, to achieve these dreams, urgent shift in approach and perceptions will be a prerequisite to overcoming the obstacles faced by their mentors-European and American integrations. These obstacles call for critical analysis of the macroeconomic, financial and socio-economic variables and ideologies prevalent in most African integration mission.

Moreover, with many ups and downs these organizations have sailed through, it is imperative that keen attention be devoted to

their position today in terms of their monetary convergence plan. However, these blocs are considered to have made some real progress and are assumed to be on track to the achievement of the 2025 target of monetary union thus the need to review some of the progress to date. This paper follows these long paths highlighting some distinguished achievements made to date, challenges to macroeconomic convergence achievement and offer recommendations for African most successful economic blocs - East Africa Community (EAC) and South Africa Development Community (SADC).

The remainder of the paper is structured as follows. Section 2 provides a literature review on integration and monetary union followed by an overview of progress on integration in Southern and Eastern Africa. Section 3 describes the criteria for monetary and fiscal policy harmonization process, particular bloc convergence analysis. Section 4 provides information on challenges to African monetary convergence plan and policy recommendations necessary for the achievement of these targets. A brief summary of the key findings concludes this paper.

### **Literature review on regional integration**

Regional economic integration members need to reinforce trade links amongst themselves. However, to achieve these intended gains, differences in governments' financing needs; correlation of countries shocks with other members; and the strength of negative monetary policy externalities needs further discussion (Debrun *et al.*, 2005).

It is highly expected that should practical convergence occur, income levels should converge at some defined level, and the poorer member states within the block will catch up with the richer ones basing the argument on achievement of European Union. However, such successes are hardly evidenced within most African trading blocs. Venables, (2002) suggests that income convergence should be a likely possible

outcome only if North- North (or at most North-South) integrates. However, South-South/ East-East integration has tended to monetary convergence although they are characterized by unequal distribution of welfare gains due to income divergence.

### **Approaches to understanding integration**

To promote better understanding of integration, Nye, (1968) argued that it is imperative to explain it from three approaches: First-economic integration approach- refers to the abolition of discrimination between financial units belonging to different national states. These have resulted in indexes as free trade area, customs union, common market, economic union and total economic integration (Evans, 1998) depending on the number of tariffs and quotas, external tariffs, free flow of factors, harmonization of economic policies and unification of policies and political institutions.

Secondly, social integration strategy- is the abolition of national impediments to the free flow of transactions with important interpersonal communications connotations as trade, mail, telephone calls and the development of transnational society. This type of integration can be of two forms: mass social integration –using these indicators. Social integration of group indicators might include percentage of students educated in other universities in the region compared to outside the region and political integration plan. Political integration is a political division of labour in a way that lumps the institutional and policy interactional aspects together as though a successful composite index with appropriate weighing. It implies a relationship of community and a feeling of identity and self-awareness. It can be subdivided into four different types: institutional, policy interactional, attitudinal and security community concept i.e. formation of transnational political interdependence).

### **Empirical approaches to understanding African monetary unions**

Most countries join a monetary union to advance in trade with member states and the rest of the world through the removal of currency transaction costs, improve on monetary and exchange rate policies and speedup the process of political integration (Adama *et al.*, 2012). However, in achieving these benefits, members incur losses from their inability to pursue independent monetary policies and failures in using exchange rate as a tool for macroeconomic modification. Therefore, several methods have been proposed in understanding African monetary union plan.

Three main approaches have identified in the literature (Debrun *et al.*, 2011). First approach attempts to measure the asymmetry of shocks, stirred by Optimum Currency Area theory (Mundell, 1961). This approach requires identifying relevant shocks and then focusing on problems these shocks create to the monetary unions. Most of these shocks are the sources of output failure amongst most developing countries. The shocks can therefore be grouped into demand and supply shocks. Supply shocks like price shocks are highly asymmetric and pose the greatest threat to a currency union than demand shocks as they are positively related to output. These shocks, therefore, determine the outcome of a monetary union. The gains from monetary union come from low transaction costs and the reduced exchange rate volatility while losses come from the inability to pursue independent monetary policies and to use exchange rate as an instrument of macroeconomic adjustment.

Second method involves comparing macroeconomic performance of existing monetary unions with that of non-members that have retained their monetary autonomy. Most research have tried to offer understanding of the complex interaction between monetary and fiscal policies in monetary unions and even further offer in depth understanding on whether membership enhances fiscal and monetary disciplines. For example, (Opolot and

Luvanda, 2008) on EAC concluded that there seems to be mixed results concerning fiscal and other macroeconomic indicators. The interactions between variables are mainly influenced by currency valuation levels with overvaluation noted to deteriorate economic development.

Final approach is measures the convergence of diverse macroeconomic indicators between member states in the region. Under this approach, prospective monetary unions are mainly evaluated based on convergence criteria. The indicators include convergence of inflation to a low value, and the reduction of public debts and debt ratios below some critical values especially 5 percent for EAC member states. These form the basis of this study.

However, most of these traditional methods have had varied shortcomings. For instance, they do not provide a means of assessing the benefits and cost ratio that accrue to a country or citizens of a country. Secondly, these procedures do not provide proper understanding of whether joining a union would be better than strengthening domestic institutions but only offer similarities with other countries. Thirdly, institutional features of a monetary union require more attention and observation on whether there is an anchorable to provide the credibility for monetary policy. Finally, it is argued that most of these approaches are not sufficiently dynamic as they overlook the increased trade and synchronicity of business cycles due to an increase in membership to monetary union.

#### **Description of the data set**

This dataset was constructed from International Monetary Fund World Economic Outlook reports database (<http://www.imf.org/external/pubs/ft/weo/2014/01/weodata/index.aspx>).

Information on each country's current account deficit, fiscal account deficit, trade levels and the underlying inflation levels covering the year 2000- 2014 was collected and analyzed accordingly.

#### **Progress on integration in southern and Eastern Africa**

Africa's share of global trade has collapsed from 6 percent in the 1980s to only 2 percent by 2002 (Commission for Africa, 2005) contrary to the vision of promoting intra-regional trade claimed by many of its unions. Some of the explanations given include: Costly and overlapping memberships; different time horizons for full liberalization of trade among member states in terms of tariff and nontariff barriers; delays in signing and full implementation of trade treaties and protocols delays by some member states.

#### **Trade**

Interregional trade in most African countries depicts an inverse relationship to its community. With almost half of the world population, the level of trade amongst African countries and rest of the world has been constant for a long time and in most cases on the declining trends. Monetary union increases intra union business by a factor of 1.7 in Africa (Tsangarides and Qureshi, 2008) thus controlling effect of free trade agreement. In addition, integration increases trade intensity and business cycle synchronization.

It is worth noting that the overall share of intra-regional trade was low (see table 1 and 2 below) considering the massive population and the agricultural potential the continent is endowed. The low levels of intra-African trade is linked to low income, public revenue loss from trade liberalization, large intra country distances and long term in getting benefits from trade (Oyejide, 2000).



**Table 5. Trade Statistics**

	Intra-regional trade (%of GDP)		% of intra African trade		% of total international trade	
	1980-90	1991-01	1980-90	1991-01	1980-90	1991-01
<b>EAC</b>	<b>3.052</b>	<b>4.193</b>	<b>76.414</b>	<b>60.046</b>	<b>10.45</b>	<b>13.61</b>
Burundi	2.518	3.104	84.94	68.498	9.422	11.21
Kenya	4.068	5.452	84.758	55.99	10.067	10.671
Rwanda	3.758	3.538	93.485	66.98	15.526	14.965
Uganda	4.11	5.201	92.311	86.191	17.237	24.07
<b>SADC</b>	<b>5.881</b>	<b>11.091</b>	<b>71.408</b>	<b>81.408</b>	<b>12.142</b>	<b>20.203</b>
Zimbabwe	2.19	3.588	21.653	17.208	6.528	6.318
Zambia	3.124	5.446	34.942	31.887	5.869	10.652
Mauritius	1.648	2.877	23.021	27.408	1.855	3.03
Malawi	4.49	7.187	26.808	27.947	8.99	12.394

Source: Carmignani (2003)

**Table 6. Intra-Regional Trade Arrangement as Percentage of Total Trade (1970-2003)**

	1970	1980	1990	1998	2003
<b>Exports</b>					
COMESA	9.7	9.1	8.1	8.9	8.6
SADC	9.4	2.7	6.9	6	6
<b>Imports</b>					
COMESA	6.7	2.8	3.4	3.9	5.8
SADC	4.9	3.8	6	6.1	6.3

Source: IMF Direction of Trade Statistics, cited in Maruping (2005)

From the table above, COMESA recorded high and stable exports trade compared to SADC between 1990- 2003 period. These might be explained by the concept of the bloc of infrastructural development aimed at reducing over dependence on apartheid under Southern Africa Development Coordinating Conference (SADCC), lack of product diversification and non-value addition activities. However, with the change of vision to economic development much of the trade, mostly exports improved from the mere 2.7 in the 1980s to 6.9 in mid 1990s (Table 2).

On the imports, SADC portion witnessed a positive and steady improvement from 3.8-6.3 between 1980 - 2003 compared to COMESA with a staggering up down movement (Table 2). The increase of imports might be explained partly by the need of the

bloc to enhance economic development between the member countries. Nevertheless, South Africa forms a major hub in terms of imports for most countries and also a major export market for other member countries produce. Intra-regional trade flow accounts for 20 percent of the entire countries but only constitutes a mere 5 percent exclusive of South Africa. Foreign Direct Investment from South Africa accounts for around 6 percent of the total stocks in SADC. In general, average correlation of terms of trade changes amongst members is quite low compared to the potential in all the countries (Table 1).

### **Monetary and Fiscal Policies**

#### **Harmonization process**

The harmonization program was adopted by heads of state in 1992 further to strengthen integration efforts and to establish a

monetary union. The process was adopted in three major phases all geared towards a common currency deadline of 2025. The phases include, first, strengthening of cooperation on macroeconomic policies. Secondly, introduction of currency convertibility and set up of an informal exchange rate union and final participation in a formal system of fixed exchange rates with economic policies harmonized by a universal monetary institution (Carmignani, 2003). After the review of the progress in

### **Pre-conditions for effective convergence of macroeconomic variables**

Abuja treaty of 1991 (Maruping, 2005; Harvery *et al.*, 2001) sets out pre-conditions for more active convergence aimed at complementing macroeconomic variables, reducing risk and cost of asymmetric shocks while fast tracking the achievement of integrated economic and monetary zones in Africa. These include;

- Competent and non-distortionary markets for products, free movement of labour and factors of production
- Efficient financing arrangements to reduce internal adjustment costs and sharing of costs and benefits of integration while incorporating the effects of exogenous shocks like adverse weather, disease, terms of trade and external financing shocks
- Correct timing, arrangement and consensus based choice of a convergence attachment
- Development and retention of expertise
- Enabling policies that reduce risks

From Optimum Currency Area and European Union policy on monetary union documents, EAC established a stage II (2011-2015) compliance criterion to include the following: (Newfarmer and Söderbom, 2012):

- Increase domestic savings-to-GDP ratio by a minimum of 20 percent
- External reserves covering 6 months imports
- Sustained level of current account deficit excluding grants

1995, members began convergence criteria for macroeconomic variables aimed at guiding smooth harmonization process (Harvery *et al.*, 2001). Among the variables identified include-inflation rate, fiscal balance, central bank financing, claims on government, money growth, domestic credit debt service and tax revenue. These variables served as eligibility tests for countries to qualify for an economic grouping.

- Sustained pursuit of debt sustainability
- Budget deficit not exceeding 5 percent of GDP excluding grants (2% including grants)
- Annual average inflation rate not exceeding 5 percent
- Interests rate to be market based
- To sustain a real GDP growth by a minimum of 7 percent

These targets have been criticized because of lack of uniform definition of concepts like domestic savings and what price index should be used. In addition, scholars had noted that the document is based on unrealistic outcomes that are beyond the control of governments like real GDP growth and domestic savings. There is a need for harmonization in measurement and definition of these variables across countries for comparison and operationalization of convergence criterion.

### **Political and institutional preconditions**

Stable and well-functioning institutional structures are necessary conditions for a monetary union. In EAC, relevant institutions supporting monetary union agenda includes; Council of Ministers, East Africa Court of Justice and East Africa Legislative Assembly. Most of these institutions compared to European Union are short in history, devoid of legal frameworks for forcing national governments to implement integration measures and therefore, have a less far-reaching mandates than European Union.

## Specific Blocs' Macro Convergence Analysis

### East African Community (EAC)

This bloc was revived in the year 2000 with principal membership of Kenya, Tanzania and Uganda. However, Rwanda and Burundi latter joined the block. The bloc covers 1.82 million KM<sup>2</sup> and it is a home to 141 million people. Poverty headcount ratio is estimated at 31.1, 35.7, 46.6, 56.9 and 68 percent for Uganda, Tanzania, Kenya, Rwanda and Burundi, respectively (Shriya *et al.*, 2011).

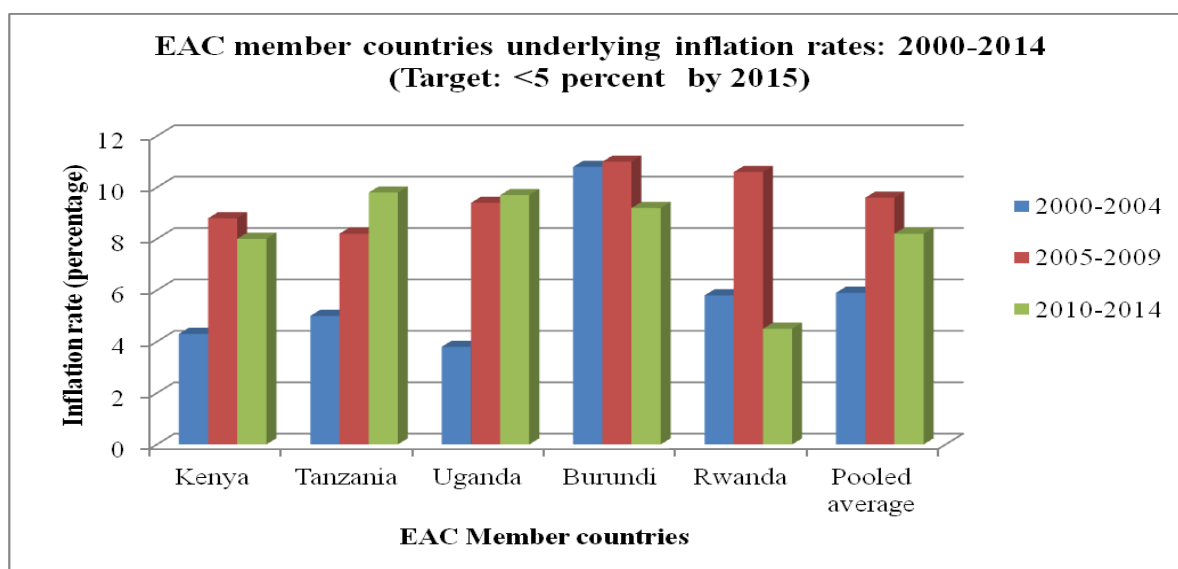
### Macroeconomic convergence status

After revival in 2000, member states started the journey with a customs union in mind making it a different community from other traditional African integrations. However, by 2005, the community had already established institutions necessary for cooperation than those of a customs union borrowed from collapsed treaty in 1977. Maruping (2005) highlighted the following

institutions as borrowed institutions from collapsed EAC: establishment of East Africa court of justice, monetary and fiscal policies including free movement of capital and cooperation in defense and security matters among others. Other targets at initiation were, establishing of a common market by 2012, monetary union by 2015 and finally a political federation.

Secondly, member states immediately set forth regional targets on monetary and fiscal harmonization policies upon which it was to measure its performance. These include- the reduction of current account deficit to GDP to a sustainable level; lowering budget deficit to below 5 percent level (excluding grants). Further targets included maintenance of competitive exchange and market interest rates; low inflation rate (single digit rate of below 5 percent); high real GDP growth rate of 7 percent annually; increasing national savings and aGDP ratio by a minimum of 20 percent in the medium term.

### The performance of EAC Macroeconomic indicators 2000-2014



**Figure 8. The performance of EAC Members' on underlying inflation as a percentage change of average consumer prices (2000-2014).**

Note: Kenya- estimates starts after 2013; Tanzania- estimates starts after 2013; Uganda- estimates starts after 2014; Burundi- estimates starts after 2012; Rwanda - estimates starts after 2012 [Source: Central Bank of Kenya, EAC website; IMF World Economic Outlook (2014); Maruping, (2005)].

**Table 7. Current account deficit (Excl. grants) as a percentage of GDP against a target of low/sustainable levels (<5%) - 2000-2014**

Current account deficit (Excl. grants)/ GDP ratio				
Specific Country	EAC Target	2000-2004	2005-2009	2010-2014
Kenya		-2.5	-3.9	-9.4
Tanzania		-4.5	-9.4	-13.6
Uganda	Low/sustainable levels (<5%)	-5.4	-5.7	-11.7
Burundi		-2	-6.2	-17.6
Rwanda		-1.7	-3.5	-8.6
<b>Pooled average</b>		<b>-3.23</b>	<b>-5.8</b>	<b>-12.2</b>

**Note:** Kenya - estimates starts after 2013; Tanzania - estimates starts after 2011; Uganda - estimates starts after 2013; Burundi - estimates starts after 2010; Rwanda - estimates starts after 2012. **Source:** Central Bank of Kenya, EAC website; IMF World Economic Outlook (2014); Maruping, (2005).

In East Africa, systematic shocks are commonplace especially in the last two decades. It can be observed that, (Figure 1), under inflation target of less than 5 percent, only Uganda has not managed to reach this target and a slight increase of 0.1 from the 2003 value was attributed to political tension within the country during the same period. These indicate shocks common in most African countries could derail the achievement of monetary convergence targets. For example, in 2008, inflation increased to more than 15 percent due to high food prices around the world.

Even though, Kenya reached the target, it is worth noting that between 2002 and 2003 there was an increase of 0.8 percent caused by political tension recorded within the country during this period (Appendix 4). It is only Tanzania that has recorded a steady downward trend in the reduction of this inflation to a manageable level of 5 percent due to stability from government to government. However, all the three members are on track on the three macroeconomic convergence indicators: underlying annual inflation, current and fiscal deficits that exclude external grant financing (Appendix 4). These confirm the findings of Opolot and Luvanda (2008) report which concluded that EAC members are a better place to a

monetary union but with reservations in thoughts on fiscal and other macroeconomic variables.

#### **Achievement of EAC on the set targets**

Marked improvements have been recorded especially in harmonization of monetary and fiscal policies through macroeconomic framework in place, partner currency convertibility, harmonized banking regulations, and value added and double taxation and pre shipment requirement (Debrun *et al.*, 2011; Maruping, 2005). Other sub committees like capital markets development authorities committee and East African Securities Regulatory Authorities have reached cross listing policies, trading policies and harmonized capital markets development activities.

Some slight improvements have also been documented in the industry, transportation, communication, energy, agriculture, natural resources, environment and the process of private sector involvement in the process. It is worth noting (Debrun *et al.*, 2011) that intra-regional trade has increased with total exports (17.5 percent) and imports (7 percent) by the end of 2007 period (table 1). What remains on the way is the achievement of a single currency, Central Bank and political federation.

### Southern African Development Community (SADC)

SADC consists of a heterogeneous group of The Republic of Southern Africa, Angola, Swaziland, Namibia, Lesotho, Malawi, Botswana, Mauritius, Mozambique, Tanzania, Zimbabwe and Zambia. Most of these countries exhibited high levels of tariff rates amongst themselves and to the rest of the world which has significantly been reduced by their integration.

#### Monetary convergence targets

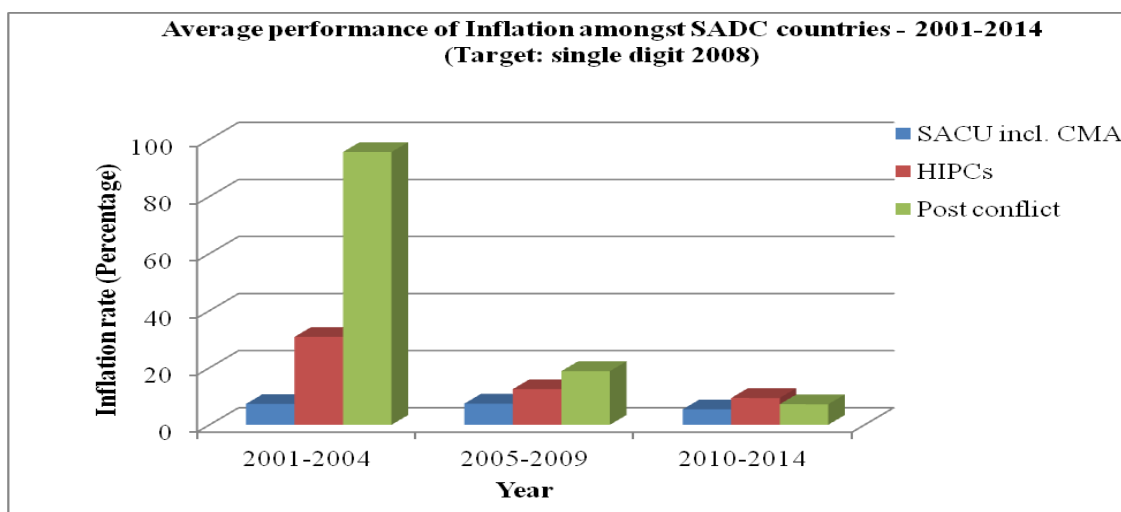
In the SADC region, monetary convergence targets of performance include: a single digit inflation rate of 5% (2012) and 3% (2018); budget deficit-to-GDP ratio below 3% (2012) and below 1% (2012-2018) and a nominal public debt to GDP ratio below 60% (2008-2018) (Debrun, 2005).

The wide disparities in the per capita incomes and economic structures across SADC countries have resulted in different groupings even amongst members. The groupings include: SACU members

including CMA; Highly Indebted Poor Countries (HIPC) and Post Conflict or in crisis countries. It is notable from figure 2, appendix 1 and table 4 above that, SADC members precisely SACU categories have reached their 2008 target of a single digit category contrary to Jenkins and Thomas (1996) and Masson and Patillo (2005) conclusion that SADC members are far from achieving monetary convergence. However, amongst HIPC; it was only Tanzania and D.R. Congo which have achieved. It is important to note that Tanzania that is a member of East Africa Community have an upper hand as the target may be part of its activity under the treaty of which it is a member (Appendix 1 and 2).

These confirm the idea that if a group of two different forms of integration shares the same common vision, it might enhance the members' faster achievement of the target. The limited achievement of set targets might be due to partial political loyalty, significant income disparities between member states and the non-implementation of protocols.

### The performance of macroeconomic indicators: SADC region 2001-2014



**Figure 9. Average performance of Inflation amongst SADC countries - 2001-2014**

**Source:** IMF (2004 and 2005): cited in (Maruping, 2005); IMF World Economic Outlook (2014)

**Note:** SACU Incl. CMA (Botswana, Namibia, South Africa, Mauritius and Swaziland); HIPC (D.R. Congo, Malawi, Mozambique, Tanzania, Zambia); Post conflict/In crisis (Angola, D.R. Congo, Zimbabwe).

**Table 8. Current account deficit (Excl. grants) as a percentage of GDP (2004-2014)**

<b>SACU (incl. CMA)</b>	<b>2004-2008</b>	<b>2009-2014</b>
Botswana	10.9	-3.5
Lesotho	19.6	-1.8
Namibia	7.5	-3.1
South Africa	-5.2	-4.1
Mauritius	-6.3	-9.5
Swaziland	-3.5	-3.4
<b>SACU incl. CMA Average</b>	<b>3.8</b>	<b>-4.2</b>
<b>HIPCs</b>		
D.R. Congo	-4.7	-7.4
Malawi	-8.6	-3.6
Mozambique	-12.3	-29.8
Tanzania	-7.9	-12.9
Zambia	-6.6	3.5
<b>HIPCs Average</b>	<b>-8.02</b>	<b>-10.04</b>
<b>Post conflict/In crisis</b>		
Angola	15.6	4.5
Congo D.R.	-4.7	-7.4
Zimbabwe	-8.6	-24.5
<b>Post conflict average</b>	<b>0.8</b>	<b>-9.1</b>

**Note:** Botswana-estimates starts after 2010; Congo D.R.-estimates starts after 2013; Lesotho-estimates starts after 2009; Madagascar-estimates starts after 2013; Malawi-estimates starts after 2013; Mauritius-estimates starts after 2013; Mozambique-estimates starts after 2013; Namibia-estimates starts after 2013; South Africa-estimates starts after 2012; Swaziland-estimates starts after 2013; Tanzania-estimates starts after 2013; Zambia-estimates starts after 2012; Angola-estimates start after 2011; Zimbabwe-estimates starts after 2013. Source: IMF World Economic Outlook (2014).

### **Challenges to African Monetary Convergence**

African integration efforts of monetary convergence have witnessed a sluggish start and might have to up the pace to achieve the desired result- a single continental currency-monetary convergence by the set deadline of 2018 (COMESA) and 2025 by other regional blocs. It was expected that members should maintain a GDP below 3 percent, a rate of inflation below 3 percent and external reserves for a minimum of 6 months import cover.

Many challenges stand on the way to this ambitious target. First, many of these blocs do not have monetary convergence criteria

as a target. As Maruping noted in 2005, only five organizations-UEMOA, CEMAC, ECOWAS, EAC and SADC shared the same vision of convergence but others were mainly formed to gain colonization and thus had no economic sense in them after independence. This might explain the start stop mentality of most blocks, lack of clear goals and vision within these groups. Secondly, there are noted differences in the socio-economic environment under which nations operate poor governance and political will and sovereignty to super national entity, policy implementation constraints; perceived real benefits and costs thus trimming commitment.

Many African countries belong to several blocs with competing and overlapping visions at the same time rather than complementing each other (Debrun *et al.*, 2005). This burdens coordination, waste public funds on annual membership fees with the final result being misuse of scarce available resources. These groups should be based on efficiency and comparative advantage view associated with the bloc and exercised only if it increases the voter utility further (Panagariya, 2000). This eliminates wasteful duplication thereby saving states from these mixed minds. Finally, there is a need to rationalize the number and membership by setting the boundaries of operation to limit the number of countries joining any trading bloc.

Most of the regional blocs have confused policies and tariff rules regarding the importation of commodities. In most instances, third world countries charge different tariffs, apply different technical standards concerning the importation of commodities from various sources. This results in increased complexity and uncertainty of business and might be the answer to limited trade witnessed in the earlier discussion (Schiff and Winters, 2003). In many blocs, lack of cost-benefit analysis criteria, low political commitment and internal consultation between member countries have slowed the ratification of protocols and delayed implementation of plans. These complexes the achievements of target as states are in various stages of economic developments within the same bloc. There is low Financial and investment needed for planning, coordination, and implementation and monitoring of the bloc activities both at local and national levels. This might be attributed to the low levels of savings as a percentage of GDP, Official Development Assistance and inadequate levels of foreign direct investment to Africa. Secondly, efficient implementation of policy has been hampered by the inconsistencies in information transfer between national and local levels. Regional integration has been largely influenced by limited capacities

available within the member countries. These limit planning, coordination, implementation and proper monitoring and adjustment of the process thus the slow pace of protocol signing.

Trade and mobility of factors of production have been very slow compared to other parts of the world from where integration has succeeded. According to (WAMZ, 2008), the convergence pace is low and need to be increased if the targets are to be achieved. The largely underdeveloped financial markets and the weak labour mobility have been offered as some of the insights into the slow pace of intra-regional business. Limited involvement of the private at both planning and implementation stage thus not maximum deliberate input from them, but they usually possess superior financial resources and own excellent productive capacity. In other countries, private sector remains weak and is still not well organized. Most African countries are affected by vulnerability to external shocks (high oil and commodity prices) and internal shocks (limited political stability; inadequate outside resources, heavy external debt burden; unfavorable terms of trade). These shocks have exerted high pressures on the members' budget making them not concentrate on the integration and implementation of agreed conditions. Finally, large initial differences exist within countries with each in various stage of economic development thus mixed results experienced in different countries. Most of the studies have documented the lack of convergence while others have reported convergence of nominal exchange rates and consumer prices (Burgess, 2009).

### **Conclusion**

The failure of most African integration to improve business and achieve economies of scale forms part of our conclusion. Therefore, there is an urgent need for keeping track of challenges and progress from time to time especially in the monetary convergence with its deadline closing nearer. A few encouraging and pessimistic results can be observed from many previous studies

highlighted in above sub topics. First, some macroeconomic variables do display a tendency to converge across countries. For example, between EAC and SADC members', inflation targets have been managed but it still not stabilized and prone to increase. On intra-regional trade, the flows are relatively low, but higher on average within some individual countries. For example, in SADC region, intra-regional trade have increased but only South Africa account for more percentage while in EAC total exports and imports follows the same trend. This gives opportunity for the countries to increase further as these economies have almost 50 percent of the African active population with them. This makes intra-regional trade to grow through the improved market potential available. Thirdly, most of these countries tend to share a common trend confirming the result that the shocks might be symmetric. However, many studies have noted that economies experiencing symmetric shocks to their macroeconomic variables are considered suitable for monetary union and thus on can walk together. For example in EAC, Kenya post-election violence increased inflation to 3.5 percent up from lower value of 2.7 percent while in Uganda the same scenario was also evidenced. In SADC the countries in crisis, experience most ups and downs in the variables that are similar to most countries in African continent.

### **Policy recommendation**

To enhance the attainment of monetary convergence, the following should be effectively discussed on a case by case basis. First, it is imperative that prior internal consultations be extensively done; involvement public sector, private sector and civil society. These should be inclusive and participatory before any integration process. This will enhance ownership, efficient monitoring and evaluation of each other's activities. Therefore, increasing the commitment of member countries; fastening ratification process, immediate implementation and adherence to protocols are necessary. At the national level, there

should be sound coordination, awareness, and transparent implementation and accountability rules to secure a permanent assurance outside a sheer political rhetoric amongst member.

To increase the pace of integration, strengthening technical capacity and human capacity for informative analysis should be a priority at national levels in member countries (Abuka, 2005). These will ensure consistency in a comprehensive policy formulation and implementation, fair and equitable sharing of the costs and benefits of integration. In addition, to reduce the average delivery cost and harmonize standards, pooling resources and expertise in handling cross-cutting regional challenges as security, infrastructure, conflict prevention HIV/AIDS, gender, peace, and governance are necessary.

There is a need for a suitable policy blend and harmonization at nationwide level targeting low inflation and fiscal discipline to reduce socioeconomic policy divergence. This should involve country specific circumstances that may work against the implementation of integration programmes to reduce the risks of conflicting policy objectives. There is the need to marshal equity investment, foreign direct investment, financial markets and technical support. This may be possible through national, regional or international private sector involvement. In addition, these newly created blocs should create an enabling institutional environment to attract finances for integration. These might only be possible through timely payment of financial contribution

Moreover, integration treaties, leadership, protocols and priorities should be very clear in providing binding frameworks and result-oriented milestones capable of guiding actions for continental integration. There is the need for strengthening of institutions responsible for the implementation programmes at the country or regional levels. This will ensure price stability and compliance supervision. In addition, these



institutions should be independent of all national and regional authorities' influences. There should be a clear distinction between the function of national central banks and East Africa Central bank. In addition, the staffing requirement and effective monitoring, and corrective mechanisms should also be taken into consideration. The timeframe for the transition to monetary convergence and macroeconomic should be agreed upon by all member states and should not be rushed (Maruping, 2005). A workable decision by all members should be agreed upon. These will offer members the opportunity to look at loopholes keenly.

Most blocs inherit underdeveloped financial markets both at local and national levels lacking debt liquidity and currency convertibility criteria to fund sectors (private and public) and cross-border investment. In doing so, there is a need to create common clearing house and central bank based on clear and realistic measurement parameters. This will enhance fiscal compliance by all member states; facilitating payments thereby promoting intra and interregional trade. These systems will reduce the risks of non-convertibility of floating currencies thus helping members who do not possess common currency thereby influences the distribution of costs and benefits in case of external shocks.

## References

- Abuka, C.** (2005). *Infrastructure, regional integration and growth in Africa*: In Africa in the world economy: The national, regional and international challenges: 2005. Retrieved from [www.fondad.org](http://www.fondad.org).
- Adama, C. S., Kessy, P., Kombe, C., and O'Connell, S. A.** (2012). Exchange Rate Arrangements in the Transition to East African Monetary Union. *International Growth Centre*. Working paper 12/0458, July 2012.
- Carmignani, F.** (2003). *The road to regional integration in Africa: Macro economic convergence and performance in COMESA*.

## Areas for further research

Based on the finding of this study, this study more analysis in understanding the welfare implications of expanding a customs union to include all African countries trading blocs or creating a new African monetary union to cover all blocs to reduce overlapping membership. In addition, there is need to expand this study to include both socio-economic, monetary, fiscal policy variables and to other macroeconomic indicators. Third, there is a need for insightful analysis of the effectiveness of budgetary institutions in planning and implementing fiscal policy. Fourth, there is a need for more analysis in analyzing cost-benefit analysis using panel data to include both time series and cross-sectional data sets. Finally, there is a need for investigation how non observable and hard to observe variables like policy makers preference and institutional quality.

## Acknowledgement

The authors wish to thank African Economic Research Consortium (AERC) through Collaborative Masters in Agricultural and Applied Economics (CMAAE) program for financial support in undertaking part of this research. We also extend our sincere gratitude to Dr. Rugube, L. (University of Pretoria, South Africa) who provided guidance in writing this paper.

Working paper No. 67: December 2003.

- Commission for Africa.** (2005). *Our Common Interest*, Report of the Commission for Africa, London.
- Debrun, X., Mason, P. R., and Patillo, C.** (2011). Should African monetary unions be expanded? An empirical investigation of the scope for monetary integration in Africa: *Journal of African Studies*, vol. 20, EARC supplement 2: 104-144.
- Debrun, X., Masson, P., and Pattillo, C.** (2005). Monetary Union in West Africa: Who Might Gain, Who Might Lose, and Why? *The Canadian Journal of*

- Economics* / *Revue canadienne d'Economie*, 38(2): 454-481.
- Evans, D.** (1998). *Options for regional integration in southern Africa*: IDS working paper No. 94: December 1998.
- Fielding, D., and Shields, K.** (2005). The Impact of Monetary Union on Macroeconomic Integration: Evidence from West Africa. *Economica, New Series*, 72(288): 683-704.
- Gibb, R.** (1997). Regional Integration in post-apartheid Southern Africa: The case of renegotiating the Southern African Customs Union. *Journal of Southern African Studies*, 23(1): 67-86.
- Harvery, C., Jenkins, C., Thomas L., Moepeng, P., and Peloentle, M.** (2001). *The Prerequisites for Progress towards a Single Currency in the Common Market of Eastern and Southern Africa*. Report prepared for COMESA Secretariat, Lusaka.
- International Monetary Fund.** (2014). *World Economic Outlook*. Retrieved from <http://www.imf.org/external/pubs/ft/weo/2014/01/weodata/index.aspx>.
- International Monetary Fund.** (2005). *World Economic Outlook 2005*, IMF, Washington D.C.
- Jenkins, C., and Thomas, L.** (1996). Is Southern Africa ready for regional monetary integration? In L. Petersson Eds., *Post-Apartheid Southern Africa: Economic Challenges and Policies for the Future*. London/New York: Routledge, 145–70.
- Maruping, M.** (2005). *Challenges for regional integration in sub Saharan Africa: macroeconomic convergence and monetary coordination. The national, regional and international challenges*, Foneded, The Hague: Dec, 2005.
- Masson, P.R., and Pattillo, C.** (2005). *The Monetary Geography of Africa*, Washington, DC: Brookings Institution.
- Mundell, R.** (1961). A theory of optimum currency areas, *American Economic Review*, 51(4):657-65.
- Newfarmer, R., and Söderbom, M.** (2012). Rwanda and the East African Monetary Union. *International Growth Centre*. Policy brief March 2012.
- Nye, J. S.** (1968). Comparative regional integration: Concept and measurement. *International Organization*, 22(4):855-880.
- Opolot, J., and Luvanda, E.** (2008). Macroeconomic convergence in the East African Community: Progress and Implications for the Proposed Monetary Union. Bank of Uganda, Mimeo. *Bank of Uganda Staff Papers*, 3(1):53-79.
- Oyejide, T. A.** (2000). *Policies for regional integration in Africa*: Economic Research papers No. 62. African Development Bank.
- Panagariya, A.** (2000). Preferential Trade Liberalization: The Traditional Theory and New developments, *Journal of Economic Literature*. 38 (2).
- Schiff, M., and Winters, A.** (2003). *Regional Integration and Development*, The World Bank/Oxford University Press, Washington D.C. /New York.
- Shriya, A., Anderson, J., Guttmann, R., Lee, R., Mandelberg, M., Maurer, S., Mayer, K., Powers, S., Sanford, C., Yang, M. and Zaidi, I.** (2011). *Moving toward a monetary union and forecast-based monetary policy in East Africa*. The Woodrow Wilson School's Graduate Policy Workshop, Princeton University, USA.
- Tsangarides, C. G. and Qureshi, M. S.** (2008). Monetary Union Membership in West Africa: A Cluster Analysis, *World Development*, 36 (7):1261–79.
- WAMZ.** (2008). *Final Report of the 23<sup>rd</sup> Meeting of the Convergence: Council of the Ministers and Governors of Central Banks of the West African Monetary Zone (WAMZ)*. Banjul, The Gambia, November 7, 2008.

## Appendices

**Appendix 1.** Specific SADC member countries performance on inflation rate (2001-2014)

Country classification		2001-2004	2005-2009	2010-2014
<b>SACU (incl. CMA)</b>	Botswana	7.4	9.6	6.5
	Lesotho	7.8	7.2	4.9
	Namibia	8.3	6.6	5.6
	South Africa	5.5	6.8	5.3
	Mauritius	-	6.9	4.1
	Swaziland	7.5	7	6.1
	<b>SACU incl. CMA average</b>	<b>7.3</b>	<b>7.4</b>	<b>5.4</b>
<b>HIPCs</b>	<b>Target: Single digit by 2008</b>			
	D.R. Congo	99.8	23.1	8.8
	Malawi	15.8	10.9	15.8
	Mozambique	12.9	8.3	6.9
	Tanzania	4.7	8.2	9.8
	Zambia	20.8	12.8	7.5
	<b>HIPCs average</b>	<b>30.8</b>	<b>12.5</b>	<b>9.4</b>
<b>Post conflict/In crisis</b>	Angola	62.8	14.9	9.9
	D.R. Congo	10.5	23.09	8.8
	Zimbabwe	213.5	18.8	2.6
	<b>Post conflict average</b>	<b>95.6</b>	<b>18.8</b>	<b>7.2</b>

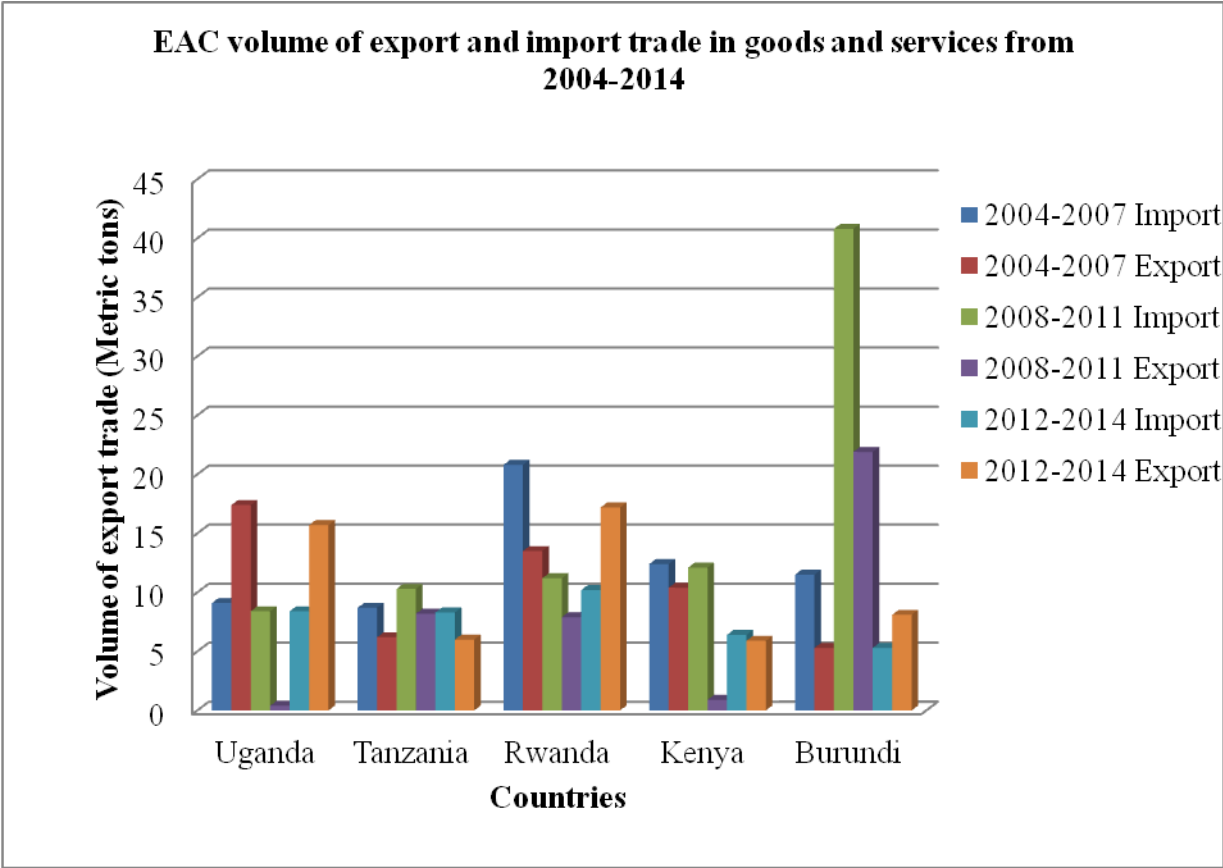
**Note:** Botswana-estimates starts after 2010; Lesotho-estimates starts after 2013; Namibia-estimates starts after 2009; South Africa-estimates starts after 2013; Swaziland-estimates starts after 2013; Mauritius-estimates starts after 2013; Congo D.R.-estimates starts after 2013; Malawi-estimates starts after 2013; Mozambique-estimates starts after 2012; Tanzania-estimates starts after 2013; Zambia-estimates starts after 2013; Madagascar-estimates starts after 2012; Zimbabwe-estimates starts after 2013; Angola-estimates starts after 2012.

**Appendix 2.** Specific SADC members volume of trade in goods and services from 2000-2014

	2000-2004		2005-2009		2010-2014	
	Imports	Exports	Imports	Exports	Imports	Exports
Zambia	11.3	9.3	10.8	9	23.5	17.2
Tanzania	2.3	23.7	8.6	4.2	9.7	7.3
Swaziland	6.4	12.9	-1.6	-5.7	-0.2	2.3
South Africa	6.9	2.9	4.4	0.9	6.7	4.9
Namibia	6.3	5.2	17	7.5	2	0.8
Mozambique	4.7	16.7	10.2	4.9	24.2	14.5
Mauritius	2.7	7.8	2.8	0.9	3.7	7.5
Malawi	10.5	34.9	5.8	7	6.5	11.8
Madagascar	2.5	-0.6	16.3	-5.9	3.8	13
Lesotho	6.5	25.2	6.9	11.7	6.7	9.2
D.R. Congo	-1.1	-20	22.5	15.7	11.3	18.2
Botswana	1.8	0.9	5.3	-2	7	7.3
Angola	8.4	6.8	28	14.1	4	0.4
<b>Average</b>	<b>5.3</b>	<b>9.6</b>	<b>10.5</b>	<b>4.8</b>	<b>8.4</b>	<b>8.8</b>

**Source:** (IMF World Economic Outlook, 2014)

**Appendix 3. Specific EAC members volume of trade in goods and services from 2000-2014**



Source: (IMF World Economic Outlook, 2014).

# Towards Clean Information and Communication Technology Campaign in Public Universities in Kenya

By

Obare E. Oteyo<sup>1\*</sup>, Okoyo H. Okora<sup>2</sup>, Oginda Moses<sup>3</sup> and Ratemo C. Makiya<sup>1</sup>

*1; Department of Information Technology, Maseno University, Kenya,*

*2; Department of Computer Science, Maseno University, Kenya*

*3; Department of Management Science, Maseno University, Kenya*

*\*Corresponding author: [oteyo@maseno.ac.ke](mailto:oteyo@maseno.ac.ke)<sup>\*</sup>; [okoyo.ho@gmail.com](mailto:okoyo.ho@gmail.com)<sup>2</sup>; [moginda@yahoo.com](mailto:moginda@yahoo.com)<sup>3</sup> and [mcratemo@gmail.com](mailto:mcratemo@gmail.com)<sup>1</sup>*

---

## Abstract

Information and Communication Technology (ICT) accounts for about 2% of total Greenhouse gas (GHG) emissions. This figure is likely to grow if the use of ICT keeps on growing unmanaged. Rapid technological advances have contributed to this situation in unanticipated ways. The adverse effects of GHG include global warming, increased pollution levels, harmful effects to the environment and depleting natural resources. This has raised concerns in the ICT industry worldwide, prompting an increasing number of organizations to implement measures geared towards reducing their carbon footprints. As such, the study presented here sought to outline how green ICT strives to address the GHG adverse effects. Green ICT is the study and practice of using computing resources efficiently to achieve economic viability and improved system performance and use while abiding by the social and ethical responsibilities. Green ICT includes the dimensions of environmental sustainability, the economics of energy efficiency, and the total cost of ownership, which includes the cost of disposal and recycling of ICT equipment. Green ICT therefore relates to acquisition, usage and disposal of ICT equipment in an environmentally friendly manner. Therefore, in a survey design that relied on interviews, questionnaires and relevant documents to access information, the current research study set out to determine whether green ICT is implemented in public Universities in Kenya. In addition, the study determined the implementation of green ICT in these institutions. Results from this study would benefit policy makers and other stake holders in public Universities in Kenya, in order to help start thinking and discussing potential role the ICT sector can play in the Universities' transition to low carbon emissions, and the steps that can be taken to accelerate that transition.

**Keywords:** ICT, Greenhouse gas, Green ICT, Global warming and Carbon Footprints.

---

## Introduction

Information and communication technology (ICT) has enabled different types of Institutions in significant ways, yielding substantial benefits to them and their stakeholders. The adoption of ICT by

various institutions and their customers will continue offering them convenience and improving operational effectiveness and efficiency. ICT can also be used in several ways to help address environmental problems we face and to improve

environmental sustainability. But ICT can also be a contributor to environmental problems confronting us. A downside of widespread adoption and use of ICT are the potentially harmful effects it can have on the environment if not managed well (Murugesan, 2011). The rapid innovations, replacement of ICT equipment and migration from analogue to digital technologies and to flat screen televisions (TVs) and liquid crystal display (LCDs) monitors are fueling the increase of electronic waste (e-waste). E-waste contains valuable and precious materials as well as hazardous materials.

The field of Information Systems (IS) research has not given enough emphasis on understanding how green ICT initiatives can be successfully implemented in various institutions. The effectiveness of green ICT implementations, its institutional impact and the validity of claims made by institutions on carbon savings remain a puzzle even when institutions are spending millions on these implementations (Jain, 2011). Hence, great emphasis and research need to get into initiatives relating to green ICT in its totality.

Improving environmental performance, tackling global warming and improving resource management are high on the list of global challenges that need addressing urgently. ICT industry needs to further improve its environmental performance for it is responsible for around 2-3% of the global carbon footprint, and ICT applications have very large potential to enhance performance across the economy and society at large (Organization for Economic Co-Operation and Development, 2009).

Consumers are a powerful ally in the fight against climate change. They can contribute to the reduction of carbon emissions by using energy more efficiently or moving to climate friendly ICT technologies that is green ICTs. For this to happen, however, they need to be sensitized to the impact of their consumption patterns on the environment and have access to affordable clean technologies

(Organization for Economic Co-Operation and Development, 2009).

In the policies and plans for sustainability and eco-responsibility in various institutions, much attention has been directed to three areas: the built environment, energy, and mobility. ICT can be both an environmental problem and an enhancer of environmental benefits if well implemented. Various institutions need to set their own performance metrics to monitor their implementation of sustainable ICT (Cisco Internet Business Solutions Group, 2008).

To consider these issues in detail, it is important to distinguish among the following effects: i) The primary effects of devices and networks; the environmental and social impacts associated with the production, use and disposal of ICT equipment ii) The secondary effects of user applications; the way in which devices and the software run, support everyday educational activities such as learning, research, management, travel and student life, and iii) The tertiary effects of the adaption of economic and social life to user applications, also referred to as the systemic effects (Peter and Lisa, 2009).

### **Green ICT**

The green ICT concept is heavily debated, discussed and analyzed, but there is little agreement on how it should be defined (Murugesan, 2011). Nonetheless, we will adopt some of the most commonly used terms to describe it.

Green ICT is the practice of environmentally sustainable ICT and it also deals with designing, manufacturing, using, and disposing of ICT equipments such as monitors, printers, storage devices, routers among others efficiently and effectively with minimal or no negative impact on the environment. Green ICT strives to achieve economic viability and improved system performance and use, while abiding by our social and ethical responsibilities. Thus, green ICT includes the dimensions of

environmental sustainability, the economics of energy efficiency, and the total cost of ownership, which includes the cost of disposal and recycling. It is the study and practice of using computing resources efficiently (Curtis and Lingarchani, 2011). As such, the main objectives of green ICT are to reduce the use of hazardous materials, maximize energy efficiency during the ICT equipments' lifetime, and promote the recyclability or biodegradability of defunct ICT equipments. The initiative to implement green ICT should be embedded in the overall transformation process for an Institution.

From the definitions above it is noticeable that for one to understand green ICT, it will be necessary for green ICT to be split/fragmented into its constituent components, and therefore measures each component using the Capability Maturity Model (CMM), a standardized way of quantifying the maturity of a process. These metrics are important for green ICT (Murugesan, 2011). Failure to define the main objectives, desires and goals at the strategic level will likely result in them not being achieved. The extent to which a University's strategy is affected depends largely on what an individual university wishes to achieve with their green ICT initiatives. For instance, whilst asking staff members 'to ensure computers are switched off when not in use', might be an appropriate measure and objective. Others, such as 'reducing the overall carbon footprint by 20% in 2 years' may require more pervasive work to be undertaken. Some things are easier to achieve than others and therefore require a greater level of planning (Curtis and Lingarchani, 2011). Whether it is about saving money, complying with governmental guidelines and regulations, promoting one's university, or expressing genuine concern for the environment, corporations, nonprofits, academic institutions, and others have begun to identify themselves as "green and sustainable" or as "going green" (Rosen *et al.*, 2011). Consequently, whatever is motivating universities may not be the central concern, but going green seems

inevitable.

The explosion of ICT, including personal computers, servers and data centers, handheld and telephonic devices, and printers, over the past few decades has led to a particular focus on ICT's environmental impact. ICT services require the integration of green computing practices such as power management, virtualization, improving cooling technology, recycling, electronic waste disposal, and optimization of the ICT infrastructure to meet sustainability requirements (Subramanian, 2011). This is evident in our universities who are embracing technology by training their students in IT skills by acquiring a number of computers to use for training. In addition, it has been established that the staff members and students are buying laptops and personal computers (PCs) and other handheld devices for use.

The concept of Total Cost of Ownership (TCO) for ICT equipment was popularized in the 1990s by research consultancy Gartner. TCO is based on the full cost of equipment over its entire life, in addition to the purchase price. So, it takes into account the purchase price, running costs, maintenance, upgrades among others factors. For PCs, Gartner has computed that the TCO over the life of a PC could exceed the original purchase price by a factor of three or more. Until recently, many TCO computations have not taken into account the costs of the power to run the ICT equipment, presenting a major anomaly. This is because ICT departments and users are rarely billed separately for the electricity they consume and have no visibility of it; a reflection of the current status in most Kenyan universities. However, TCO based calculations are now more important as we consider the costs associated with equipments in terms of the carbon they generate (Murugesan, 2011).

### **Significance of Green ICT**

Information and Communication



Technology (ICT) accounts for above 2% of total Greenhouse gas (GHG) emissions and this figure is likely to grow if the use of ICT keeps on growing unmanaged. Rapid technological advances have contributed to this situation in unanticipated ways. The adverse effects of GHG include global warming, increased pollution levels, harmful effects to the environment and depleting natural resources. This has raised alarm in the ICT industry worldwide, prompting an increasing number of organizations to implement measures geared towards reducing their carbon footprints. (Jain, 2011).

The first order impacts of ICT equipment are associated with production, use and disposal of ICT hardware which have a direct impact on the environment, the second order impacts are caused by the changes in structure and behavior of their application. In the longer term this leads to the third order effect of ICT also known as the rebound effects. Rebound effects occur as resources are widely available and are used in excessive quantities to offset any savings that were claimed against a substitute (Jain, 2011). This also calls for a greater concern in our universities and urgently need to be addressed.

Green ICT objectives are driven largely by two major categories of drivers that is internal drivers and external drivers. Internal drivers are those which are created and controlled within an institution and could include areas such as delivering cost savings, business efficiency gains or enhancing market reputation. External drivers are those which are external to the institution and to which there is limited control on. These could include government legislation or policies, regulations, competition and others (Curtis and Lingarchani, 2011).

ICT is a significant consumer of electricity worldwide and it is at par with the airline industry (provide reference for this statement). Therefore it makes sense, as emission reduction becomes desirable and

even mandatory, that ICT users should look at ways of reducing the energy consumption of their systems. Yet there is more to green ICT than merely reducing the emissions from ICT devices within the organization. Therefore, the importance of green ICT permeates all aspects of the institution. The following trends are impacting data centers, and to a lesser degree, desktop computers, and driving the adoption of green computing practices; Rapid growth of Internet, increasing cooling requirements, increasing energy costs, restrictions on energy supply access, lower server utilization rates and ICT impacts on the environment. The increasing reliance on electronic data is driving the rapid growth in the size and number of data centers. This growth results from the rapid adoption of Internet communications and media, the computerization of business processes and applications.

### **Challenges Facing the Implementation of Green ICT**

The enablers and barriers to ICT transformation need to be understood at both micro and macro levels. However, green ICT implementations in various Universities have not been sufficiently analyzed at the micro level which represents a gap in the current academic literature. Green ICT implementations in various Universities appeared simple in concept but when it was approached in details, it was found to be quite complicated. Hence it is important to focus on studying these implementations at the institutional level like a university (Jain, 2011).

Green ICT implementations represent an Institutional change and hence it is important to know how the existing work practices in a University are modified or how new work practices are being introduced to reduce the impact of institutional ICT implementations on the environment. Different stakeholders have different perspectives and vested interests in different institutions and it is important to maintain harmony amongst stakeholders to succeed in a changing practice. Therefore it is essential

that a University maintains healthy relationships among its stakeholders and within the University for the success of this initiative (Jain, 2011).

Green ICT initiatives are going beyond simply operational or tactical activities, and the initiatives are becoming part and parcel of business strategies and planning. So if the initiatives are not integrated within a University's strategies and planning, it will be difficult to implement it (Curtis and Lingarchani, 2011). Agreeing on what the green ICT principals and objectives will be and adhering to the plan of implementing them is another challenge, as well as changes in behaviors associated with new business processes and associated applications.

Cost is also another potential challenge, especially where Institutions have significant investment tied up in existing environments or where systems and infrastructure have been depreciated in value to the point where it has a limited investment impact on a University. As such, Universities need approaches that will help plan these changes in better alignment with specific lifecycle policies for infrastructure. Where a university has not attempted a project of this nature, a suitable migration strategy should be developed to provide a roadmap that will take the institution from the current state to the desired state. The migration roadmap should include a review and agreement of what the university wants to achieve environmentally so that this can be evaluated in the context of green ICT (Curtis and Lingarchani, 2011).

The current research has documented that there is no official legislation to enforce green ICT practices within most universities, and therefore there is no such practice that has been implemented in those universities. We can summarize this section by deducing that some factors related to green ICT practices which are not implemented are; official legislation enforcing green ICT practices, pressure from management/customers and employees lack

the appropriate knowledge or training.

### **Electronic (E)-Waste**

Electronic Waste (E-Waste) is any litter created by discarded electronic devices and components as well as discarded and degenerating substances involved in their manufacture or use. E-Waste covers computer parts and monitors, printers, cables, batteries, Compact Discs (CDs), Digital Versatile/Video Discs (DVDs), televisions, cell phones, microwaves, Video Cassette Recording (VCRs) players, just to mention but a few. Waste from Electrical and Electronic equipment (WEE) is the other name for e-waste. E-Waste is now recognized as one of the fastest growing waste stream in the industrialized and industrializing countries. The three major groups in which electronic waste contributors can be categorized are computers, mobile phones and television sets (Godbole, 2011).

The rapid innovations and replacement of ICT equipment and migration from analogue to digital technologies and to flat screen Televisions (TVs) and LCD monitors are fuelling the increase of e-waste. E-waste contains valuable and precious materials as well as hazardous materials. For instance, about 60 elements from the periodic table can be found in some complex electronics. It remains unclear how universities address the various elements in the electronic equipment.

Over the last decades the electronics industry has revolutionized the world, electrical and electronic products have become ubiquitous of today's life around the planet. Without these products, modern life would not be possible in post-industrialized and industrializing countries. These products serve in such areas as medicine, mobility, education, health, food-supply, communication, security, environmental protection and culture (United Nations Environment Programme and United Nations University, 2009).

In some cases, after the disposal of e-waste as landfill, environmental impacts can continue to be seen through leaching. The resulting leachate often contains heavy metals and other toxic substances which can contaminate ground and water resources. Even the state-of-the-art landfills which are sealed to prevent toxins from entering the ground are not completely tight in the long-term. Older landfill sites and uncontrolled dumps pose a much greater danger of releasing hazardous emissions. Mercury, Cadmium and Lead are among the most toxic leachiest and those are the common elements used in PCs (Godbole, 2011). The way forward as far as the landfills is concerned remains unknown.

Adjusting the well-known and commonly-used tonnage or mass metric to incorporate factors such as value, energy used, and environmental impact provides a more comprehensive method of measuring the program's success. The measures to take into consideration are: quality of inflows and outflows of e-waste, embedded materials that must be extracted from these flows, value-added performance of individual recyclers, net energy consumption of recycling versus new manufacture and environmental impact of primary versus secondary commodities (Godbole, 2011).

There is no doubt that electronic waste management is the new challenge of the millennium or put another way, it is the curse of the digital economy. One thing is certain; electronic waste is with us to stay and it's likely to continue increasing in volume. We are already facing a serious challenge by refurbishing and reuse of computers, while desirable and encouraged, just delays the ultimate e-waste disposal problem (Godbole, 2011).

Technological advancements have made our lives faster, easier and more efficient, but with the downside of increasing the proliferation of e-waste. The e-waste pile is growing around the world for it runs into millions of tons annually. A number of

countries are drafting legislation for the environmentally friendly disposal of this waste. Disposal techniques vary widely from country to country because they include materials which are valuable and recyclable, as well as toxic. While modern technologies allow for nearly hazard-free recycling of e-waste, precautions must be taken to control harmful emissions and toxins that cause detrimental impacts on health and the environment (Godbole, 2011).

### **Some of the State-of-the-Art in relation to Green ICT adopted by some of the Universities Virtualization**

Virtualization is becoming a primary strategy to address the growing business computing needs. It is fundamentally about ICT optimization in terms energy efficiency and cost reduction. It improves the utilization of existing ICT resources while reducing energy use, capital spending and human resource costs (Subramanian, 2011). This is evident in a few Universities who are trying to virtualize their systems. Virtualization is the emulation of one or more servers/workstations within a single physical computer, that is, the emulation of hardware within a software platform allowing a single computer to take on the role of multiple computers.

Resource virtualization is at the centre of most cloud computing. The concept of virtualization allows an abstract, logical view on the physical resources that includes servers, data stores, networks, and software. The basic idea is to pool physical resources and manage them as a whole and that individual requests can then be served as required from these resource pools. For instance, it is possible to dynamically generate a certain platform for a specific application at the very moment when it is required. Instead of a real machine, a virtual machine is used (Baun *et al.*, 2011).

In the 21<sup>st</sup> century, we are in a transition from a device-centric world to an information-centric world. It is about how you make the information useful and

available and make that the centre of people's lives rather than of specific devices. Devices will have to cleave to the information instead of the other way around. ICT infrastructure, the plumbing, will fade away for most users and businesses, and will increasingly be left to professional providers (Williams, 2010).

We can summarize that some of the main benefits of virtualization to a University are; Reduction of management and resource costs, optimal use of hardware resources, improved business flexibility and improved security and reduced downtime.

### **Cloud Computing**

Cloud Computing is a buzz-word in today's ICT that nobody can escape. There are many interpretations of this term, but there is no standardized definition. Cloud computing fosters the provision and use of ICT infrastructure, platforms, and applications of any kind in the form of services that are electronically available on the Web. The term cloud hints at the fact that these services are provisioned by a provider on the Internet or on the intranet of a larger institution. Users of cloud services, on the other hand, can propose their own offerings as services on the Internet or even on an intranet (Baun *et al.*, 2011).

The rise of the cloud is more than just another platform shift that gets ICT experts excited. It is transforming the ICT industry, by changing the way people are working and the way different institutions are operating. The interesting aspect about cloud computing is that we have redefined cloud computing to include everything that we already do at home, workplaces, and learning institutions. It is now becoming difficult to think about technology without thinking about cloud computing.

Cloud computing is the dynamic delivery of ICT resources and capabilities as a service over the Internet. Cloud computing is a way of computing in which dynamically scalable and often virtualized resources are provided

as a service over the Internet. It generally incorporates infrastructure as a service (IaaS), platform as a service (PaaS), and software as a service (SaaS). It is a model for enabling convenient, on-demand network access to a shared pool of configurable computing resources like networks, servers, storage, applications, and services that can be availed and released with minimal management effort or service provider interaction (SARNA, 2011).

Cloud computing has become a significant technology trend, and many experts expect that cloud computing will reshape ICT processes and the ICT marketplaces. With the cloud computing technology, users use a variety of devices, including PCs, laptops, smart phones, just to mention but a few devices to access programs, storage, and applications over the Internet, via services offered by cloud computing providers hence cutting down on cost (Raton and Furht, 2010). There is great potential for cloud computing applications to help various universities into the true green ICT at lower costs compared to traditional ICT company solutions.

We can summarize that cloud computing is a complex infrastructure of software, hardware, processing, and storage that is available as a service with benefits such as; the availability of an incredible array of software applications, access to lightning-quick processing power, unlimited storage, and the ability to easily share and process information and all these are available through a browser at any time one accesses the Internet (Subramanian, 2011).

### **Thin Client**

Thin clients are a cost-effective solution for institutions that need several computers that all do the same thing or do perform similar operations. For example, students in a given university laboratory could all run the same program from a server, each using his/her own thin client machine. Thin clients also make it easier to manage computer networks since software issues need to be managed

only from the server instead of on each machine.

A thin client sometimes called a lean or slim client is a computer or a computer program which depends heavily on a server to fulfill its computational roles which is different from the traditional fat client, where a computer is designed to take on these roles by itself.

### **ISO 14001**

Fundamentally, it is everyone's job to protect the environment by preventing pollution and continually improving the air we breathe, the water we drink, and the earth we inhabit. Organizations are becoming increasingly concerned in achieving sound environmental performance, often while delivering cost savings and demonstrating that you are a "Good Corporate Citizen". Many organizations decide to Implement ISO 14001 and obtain registration because it assures customers, shareholders, suppliers, regulators and the community at large that the company has a good Environmental Management System (EMS) in place. An organization with an effective EMS will typically meet customer expectations and comply with regulations better than an organization that does not have an effective EMS. Many organizations require their suppliers to have ISO 14001 Registration (The 14000 Store Team).

ISO 14001 refers to a series of standards on environmental management tools and systems. ISO 14001 deals with a company's system for managing its day-to-day operations and how they impact the environment. The ISO standards do not set any environment performance values; they only state that the institution must exhibit a commitment to comply with all relevant laws and regulations. In this sense, they are "concerned with establishing "how to" achieve a goal, not "what" the goal should be. ISO 14001 has received certain criticism. First, the ISO does not provide specifications or require institutions to report emission levels. Second, the institutions' environment

commitments are measured against their own environmental policies; consequently, there is little incentive for them to go beyond mere compliance with local environmental laws. Further, since the standards are determined by local environmental laws, they vary across countries. As a result, institutions' environmental policies vary with their locations and most do not transfer their clean technologies to locations with lax regulations (Godbole, 2011).

ISO 14001:2004 specifies requirements for an environmental management system to enable an organization develop and implement a policy and objectives which take into account legal requirements and other requirements to which the organization subscribes, and information about significant environmental aspects. It applies to those environmental aspects that the organization identifies as those which it can control and those which it can influence. It does not itself state specific environmental performance criteria (International Organization for Standardization, 2011). This calls for various institutions to come up with their own green ICT policy in the quest of maintaining an environmentally sustainable ICT.

### **Conclusion**

The classic hierarchical organizational structure of twentieth century companies is being redesigned and this gives rise to the network organizational structure of the virtual enterprise. Virtualization is one of the technologies implementing green ICT. In the virtual enterprise the activities performed internally are those that directly add value to the company's products and which its customers pay for the services (Michae and Derek, 2011).

Organizations are embracing green ICT guidelines to cut ICT costs, utilize the ICT resources to their maximum, save on power bills and to save the environment from the ill effects of ICT usage. Thus, organizations are now actively looking for optimized ICT solutions that have a lower carbon footprint. This phenomenon of organizational ICT

change for the environment is growing across a wide range of industries and geographical regions, but how much of this is being adopted by the public universities in Kenya is not well documented (Jain, 2011). This paper is intended to be a basis for policy makers to develop justifiable arguments as to why green ICT should be recognized as a vital part of the massive stimulus spending. The targeted institutions are public universities in Kenya which will inevitably shape socio-economic growth for the next decade. In particular, this paper further aims at raising awareness among ICT policy and decision makers on environmental impacts of ICT policies and initiatives, in addition to the need for consideration of socio-economic dimensions in the planning and implementation process (Preminda and Atsuko, 2009).

From government policy to energy market economics and organizational dynamics, there are many reasons why ICT departments should consider and design sustainability into their actions. The most obvious is that being "green" simply means being efficient and not wasting money, resources or time (Global Action Plan, 2009).

The push for green ICT is becoming a big wave among various institutions in the world. More and more business stakeholders are becoming aware of the need to implement ICT infrastructures that are guaranteed to be "green." It must be pointed out that recognizing the need to adopt green ICT is different from actually putting it into action. As of now, most institutions, whether big or small, still do not know where to start in green computing (Subramanian, 2011). This gives more reasons why it is important to come-up with customized guideline to implementing green ICT in Kenyan public universities.

### Recommendations

Green ICT training should be performed to all ICT users is advised.

### References

- Baun, C., Kunze, M., Nimis, J., and Tai, S.** (2011). *Cloud Computing Web-Based Dynamic IT Services*. New York: Springer-Verlag.
- Cisco Internet Business Solutions Group.** (2008). *Green ICT: Sustainability for the 21st Century*. Retrieved July 26, 2013, from Connected Urban Development: <http://www.ictliteracy.info/rf.pdf/CiscoGreenICTReport2008.pdf>
- Council of European Professional Informatics Societies (CEPIS).** (2012). *Energy Efficient Enterprise in Europe Green ICT Awareness in Organisations*. Retrieved August 23, 2013, from <http://cepis.org>: [http://cepis.org/media/GreenICTSurveyReport\\_v1.20131.pdf](http://cepis.org/media/GreenICTSurveyReport_v1.20131.pdf)
- Curtis, D., and Lingarchani, A.** (2011). *Green ICT System Architecture Frameworks*. In B. Unhelkar, *Handbook of Research on Green ICT: Technology, Business and Social Perspectives* (pp. 446-457). New York: IGI Global.
- Global Action Plan.** (2009). *Green ICT Handbook A Guide to Green ICT-Handbook.pdf*. Retrieved August 6, 2013, from <http://greenict.org>: <http://greenict.org.uk/sites/default/files/Green%20ICT%20Handbook.pdf>
- Godbole, N.** (2011). *E-Waste Management: Challenges and Issues*. In B. Unhelkar, *Handbook of Research on Green ICT: Technology, Business and Social Perspectives* (pp. 480-502). New York: IGI Global.
- International Organization for Standardization.** (2011, November 3). *ISO 14001:2004 Environmental management systems -- Requirements with guidance for use*. Retrieved September 5, 2013, from [www.iso.org](http://www.iso.org): [http://www.iso.org/iso/catalogue\\_detail?csnumber=31807](http://www.iso.org/iso/catalogue_detail?csnumber=31807)
- Jain, H.** (2011). *Green ICT Organizational Implementations and Workplace Relationships*. In B. Unhelkar, *Handbook of Research on Green ICT: Technology, Business and Social Perspectives* (pp. 146-150). New York: IGI Global.

- Michae, H., and Derek, H.** (2011). *Business in the Cloud WHAT EVERY BUSINESS NEEDS TO KNOW ABOUT CLOUD COMPUTING*. New Jersey: John Wiley and Sons, Inc.
- Murugesan, S.** (2011). Strategies for Greening Enterprise IT: Creating Business Value and Contributing to Environmental Sustainability. In B. Unhelkar, *Handbook of Research on Green ICT: Technology, Business and Social Perspectives* (pp. 131-145). New York: IGI Global.
- Organization for Economic Co-Operation and Development.** (2009, June). *Towards Green ICT Strategies: Assessing Policies and Programmes on ICT and the Environment-42825130.pdf*. Retrieved August 6, 2013, from <http://www.oecd.org: http://www.oecd.org/internet/ieconomy/42825130.pdf>
- Peter, J., and Lisa, H.** (2009). *Sustainable ICT in Further and Higher Education*.
- Preminda, F., and Atsuko, O.** (2009, December). *Green ICT: A "Cool" Factor in the Wake of Multiple Meltdowns-IDD\_TP\_09\_10\_of\_WP\_7\_2\_907.pdf*. Retrieved August 6, 2013, from [http://www.unescap.org: http://www.unescap.org/idd/working%20papers/IDD\\_TP\\_09\\_10\\_of\\_WP\\_7\\_2\\_907.pdf](http://www.unescap.org: http://www.unescap.org/idd/working%20papers/IDD_TP_09_10_of_WP_7_2_907.pdf)
- Raton, B., and Furht, B.** (2010). *Handbook of Cloud Computing*. New York: Springer Science+Business Media.
- Sarna, D. E.** (2011). *Implementing and Developing Cloud Computing Applications*. New York: Taylor and Francis Group.
- Subramanian, C.** (2011). Adopting Green ICT in Business. In B. Unhelkar, *Handbook of Research on Green ICT: Technology, Business and Social Perspectives* (pp. 643-651). New York: IGI Global.
- The 14000 Store Team. (n.d.).** *14000 Store The tools you need to Achieve and Maintain ISO 14001*. Retrieved October 22, 2013, from <http://14000store.com: http://14000store.com/what-is-iso-14001.aspx>
- United Nations Environment Programme and United Nations University.** (2009). *Sustainable Innovation and Technology Transfer Industrial Sector Studies RECYCLING-FROME-WASTETORESOURCES*. Berlin: Oktoberdruck AG.S
- Williams, M. I.** (2010). *A Quick Start Guide to Cloud Computing Moving your Business into the Cloud*. London: Kogan Page Limited.

# Sustainable Use of Business Intelligence Tools at Kisii Bottlers (K) Limited

By

**Ratemo Cyprian Makiya<sup>1\*</sup>; Obare Erick Oteyo<sup>1</sup>**

*1; Department of Information Technology, Maseno University, Kenya*

*Corresponding author: [\\*cratemo@maseno.ac.ke](mailto:cratemo@maseno.ac.ke) ; [^1oteyo@maseno.ac.ke](mailto:oteyo@maseno.ac.ke)*

---

## Abstract

With the increased use of computer-based information systems in organizations, volumes of electronic data is gathered and stored. This data could be a useful resource in supporting management decision making. Business Intelligence is the way by which organizations can unify and sift the vast amounts of electronic data available so as to glean insights that support management decision making. We focuses on a solution to the current underutilization of Business Intelligence tools in improving decision making from existing volumes of collected electronic data. We assessed the status of Business Intelligence in the organization and determined the appropriate Key Performance Indicators that can be tracked to enhance the use of business intelligence. Data was collected through the use of interviews, and thematic analysis method was used to analyze the responses obtained. Purposive sampling method was used to get respondents, drawn from business and Information Technology functions of the organization. Whereas this study was confined to specific company in the soft drinks industry, the findings can be of relevance to a wider group of related organizations. The study has generated an in-depth understanding of the issues related to the use of business intelligence and anticipated to make a contribution to the existing knowledge on Business Intelligence in general in various organizations. The findings of this research will help shape policies relating to business intelligence for better realization of organizational goals.

**Key words:** Computer-based information systems, key performance indicators, business intelligence.

---

## Introduction

The study was conducted at Kisii Bottlers Kenya Limited, a franchise of the Coca Cola Company in the larger Coca Cola Africa administrative region, and Coca Cola East Africa region. Use of business intelligence to support management decision making at Kisii Bottlers Kenya Limited was noted not to be optimal as manifested in long unnecessary reports, inaccessibility of reports

to some report users and dissatisfaction by some report users, among others.

This study was informed by systems theory and in the context of this study the system is an integrated computer based management information system in the organization; that gather, store, process, evaluate, and distribute needed, timely, and accurate information to management decision



makers. Enterprise reporting is the component of the system that delivers timely, accurate and needed information to decision makers.

The main aim of the study was to investigate the use of Business Intelligence in the soft drinks industry, with a view to proposing a solution to enhance the use of Business Intelligence. The study specifically sought to assess the extent of use of Business Intelligence in the soft drinks industry, to identify the challenges experienced in the use of Business Intelligence, to determine appropriate Key Performance Indicators that can be tracked to enhance use of Business Intelligence.

### **Use of Business intelligence tools in the soft drinks industry in Kenya**

#### ***Adoption and use of Information Technology in the soft drinks industry***

Information Technology has emerged as a basic fact of life in the business strategies of major corporations (Galliers, 1994). Information Technology facilitates the convergence of communications, computers, and information. Currently, companies across the world typically spend about six percent of their total revenue on Information Technology (Anandarajan and Wen, 1999).

Information and communication technologies are the building blocks for socioeconomic development, and therefore nations around the world are attempting to capitalize on the capabilities of this technology to support planning, development, and growth processes (Davern and Kauffman, 2000). Developing nations have tried to invest in its information infrastructure with a focus on developing information and management support systems for the decision-making process in both government and private sectors. The emphasis on using management support systems such as decision support systems and executive information systems to meet socioeconomic development objectives has been central (Anandarajan and Wen, 1999).

Information technology provides companies with the ability to process large amounts of information and do so in a way which presents the information in a clear and concise manner to employees (Business Objects, 2005). The Coca-Cola multinational soft drinks Company, which is a leader in the soft drinks industry locally and worldwide, has a wide market base with many outlets, resulting in the handling of a lot of electronic data through information technology systems. Anticipated benefits of implementing information technology systems include improvements in productivity, better profit performance, and a higher degree of accuracy among information within the firm. The ability to share information among employees is also enhanced (Earl, 1993). Technology now allows information handling to be decentralized via the use of networks and personal computers. Most information systems allow multiple users to access information at the same time, and with flexibility. So employees can write reports and make modifications to their portions of the system quickly and easily. When this is the case, the benefit to organizations can include higher morale as well as higher productivity (Business Objects, 2002).

#### ***The need for faster access to business information in the soft drinks industry***

Lots of money has been spent on enterprise applications such as Oracle and Siebel to replace legacy applications, improve efficiencies and gain greater competitive advantage. A lot more has been spent in installing and customizing these applications to meet each organization's unique business requirements. Above the improved efficiencies, a much greater potential lies within this substantial investment and remains largely untapped (Bakos, 1995). According to Forrester Research, the next wave of competitive advantage will come from empowering front line decision makers with the information that lives within these powerful systems.

Group believes that intelligent use of information in decision comes from the synergy between decision makers and the tools they employ. True Business Intelligence systems include not just the tools and technologies that support quality decision-making, but also the decision makers themselves. Once data is obtained from a variety of sources and integrated with other relevant data the derived information must be delivered to the decision maker in a way that can be meaningfully used and analyzed and when business users can begin to obtain rapid answers to their questions, business intelligence becomes a strategic weapon. "Enterprises having difficulty coping with three terabytes of data today need to quickly find solutions for dealing with 300 terabytes of data tomorrow" (Davern and Kauffman, 2000). To optimally guide the corporate ship on the right direction, one factor will remain paramount: the need for data. Users will always overwhelm the Information Technology department in their search for answers to business questions unless a cost-effective solution which enables users to help themselves is present.

New business initiatives of Kisii Bottlers Kenya Limited demand access to vital information and since the amount of data stored will continue to escalate, along with the number of users and their increased requirements for the use of that data, business intelligence remains a paramount strategy to tap from the data. A faster-paced market, a shifting business model, and an investor community that demands timely information on a company's status are only a few of the concerns faced by executives and managers of such an organization.

#### ***Use of Business Intelligence in the soft drinks industry***

As business profits decline, organizations are recognizing that the provision of quality information is a key to gaining competitive advantage. Supported by increasing improvements in storage, data warehousing and on-line analytical processing (OLAP)

solutions, the Business Intelligence market is expected to continue to rise into the coming years and forecasts predict the Business Intelligence field will grow at 23% annually (Darrow, 2003).

Business Intelligence is an approach to management that allows an organization to define what information is useful and relevant to its corporate decision making (Vitt, 2002). According to Whitehorn there is little consensus on a definition for Business Intelligence; often it depends on who is defining it, and frequently, what they are selling. For instance, 'Business Intelligence: The IBM Way' has a very specific focus on data warehousing and on-line analytical processing (OLAP) (Whitehorn and Whitehorn, 1999). Not surprisingly, IBM's product suite (IBM Visual warehouse and DB2 OLAP server) fits in perfectly with their Business Intelligence focus. Whilst acknowledged that there is little academic research on Business Intelligence (Grey, 2003; Jagielska *et al.*, 2003), there is a growing body of literature, largely vendor and industry focused. This literature tends to centre Business Intelligence as the query, reporting and analysis functions of decision support systems, although these vendor definitions sometimes include analytical applications. This view is also supported by a number of the top Business Intelligence vendors (Business Objects, 2003; Cognos, 2003; MicroStrategy, 2003; SAS, 2004).

In 2007, there was an overwhelming interest on who providers of Business Intelligence services were. IBM acquired its long-time business partner and business intelligence software pioneer Cognos for \$5 billion in cash. This was followed by Oracle's \$3.3 billion buyout of Hyperion in February the same year and SAP's acquisition of Business Objects for \$6.8 billion in October the same year. Also, Cognos had acquired privately held Celequest Corporation, a provider of operational business intelligence solutions based in Redwood City, California earlier. These deals leave MicroStrategy and SAS as the last remaining standalone Business

Intelligence players. These business activities surrounding Business Intelligence indicate the world's recent interest in this area of computing (Business Objects, 2002).

After spending years and possibly millions of investment money in Enterprise Resource Planning - style systems, many companies now store vast amounts of transactional data. The role of business intelligence is to extract the information deemed central to the business, and to present or manipulate that data into information that is useful for managerial decision support (Business Objects, 2007). In their simplest form, these tools permit a decision maker to access an up-to-date, often consolidated, view of business performance (Business Technology Group, 2006). The Coca-Cola Kisii Bottlers Kenya Limited, like other Coca-Cola franchise companies has a heavy distribution channel intended to get as much of her products as possible to customers and as such collects lots of electronic data that is a resource for decision making information through business intelligence tools.

### **Methodology**

This study adopted qualitative approach and interviews were used to collect data. The study followed a multi-informant design as a source of research triangulation for extracting improved contextual information and highlight perceptual differences between key participants across different areas within the organization. In this Information Technology study, this design was used to obtain varying opinions among Information Technology professionals and business management persons about the use of Business Intelligence. Thematic analysis method was used to analyze the responses obtained from respondents.

### ***Data analysis and interpretation***

The interview schedule that was used in the study was divided into three parts. The first part sought information on the extent of use of Business Intelligence in the organization; the second part was used to gather information on the challenges experienced in

the use of Business Intelligence and the third part for collecting information about Key Performance Indicators in use of Business Intelligence.

### **Results**

#### ***Extent of use of business intelligence tools***

Findings indicated that the commonly used electronic sources of information that aided decision-making processes in the organization in the past year were as follows; database reports, Microsoft Excel spreadsheet documents, Microsoft Word documents and internet resources in varied forms. All these electronic sources of information were used in the organization for decision making albeit different frequency. Database reports were however reported to be the most commonly used electronic source of information compared to the rest with 86% of the respondents confirming reliance on database reports for decision making. 76% of the respondents confirmed that they used Microsoft Excel spreadsheet documents in that year, 62% used Microsoft Word documents and 45% used internet resources for decision making information.

According to the information collected in the first part of the interview schedule that required respondents to give information on the extent of use of database reports in the organization, database reports were found to be easy to use due to the fact that they contained accurate information for decision making. This was so because they depended on data repositories that were systematically populated with relevant data about key functions of the organization through reliable and systematic computer based means. The reason for the small percentage of respondents not relying on database reports was their inability to identify the appropriate reports for particular decision-making-information needs. The percentage of respondents who used spreadsheet documents as a source of decision making information did so because the data having been collected using spreadsheets, ad hoc analysis of the collected data was best done

and output presented to management decision makers using spreadsheets. The information on spreadsheets had a limitation of being re-usable since spreadsheets were mostly prepared to derive particular information for a particular purpose or within a timeline without bearing in mind possible need of the same information by the same or different users at a later time. The percentage of respondents who used word documents as a source of decision making information did so because most reports, policy documents were done and stored in this format and such documents contained useful information for decision making. The last category of electronic information resource and least commonly used was internet accessible documents, in various formats. The respondents who used internet resources were however those who were not only computer literate but also were knowledgeable of where and how to get information on the internet that would empower them in making decisions.

***The general factors affecting use of database reports in the organization***

The factors that affected the use of database reports were analyzed under the following identified categories; Design and development of reports, generation of reports, distribution of reports, review and revision of reports.

Design and development of database reports was explained to respondents as the creation of conceptual reporting solutions and the transformation of the conceptual solutions into executable database reports. It was found that the design and development of the original database reports of the organization were based on a borrowed conceptual model from a sister franchise organization, but a number of customizations were made over time to meet specific decision-making-information needs of the organization's report users. User involvement, competence of developers, and management support in the design and development of database reports had the most influence in the use of database reports

in the organization albeit varied frequency. The specific factors that needed to be checked to achieve better use of database reports in the organization include; user commitment in giving necessary information to help in developing useful reports, the developers' attitude about the user's ability to make contribution about the information they desired on reports and how they wanted the information presented on the reports, management commitment in providing financial resources and other possible help and finally choice of software tools and supportive software and hardware infrastructure for the design and development of reports and their continuous use.

Generation of database reports was explained to respondents as the production of viewable reports from stored electronic data at a particular time by executing the report designs against the data. Frequency of report generation, promptness of report generation, format of generated reports and mode of administration of report generation had the most influence in the use of database reports in the organization albeit varied frequency. The specific factors that needed to be checked to achieve better use of database reports in the organization include; users' attitude about the importance of report information, inaccessibility to the reporting system by less privileged employees largely due to infrastructural inadequacies and power outages, ease of use and compatibility of format of generated report with other data in different format and finally the mode of administration of generation of reports.

Distribution of reports was explained to respondents as the process of delivery of generated reports to the intended users in the right form using a specific medium. Medium of report distribution and mode of administration of the report distribution process had the most influence in the use of database reports in the organization albeit varied frequency. The specific factors that needed to be checked to achieve better use of database reports in the organization include;

the reliability of the medium in delivering reports as quickly as possible after being generated, the issue of discipline of report users in accessing generated reports.

Review and Revision of database reports was explained to respondents as the assessment of reports in an effort to identify possible improvements that can be incorporated to improve them, and the actual modification of those reports as per the review. User involvement in the review, competence of developers in facilitating identification of the necessary improvements and the inclusion of those improvements in the reports and management support in the review and revision processes had the most influence in the use of database reports in the organization albeit varied frequency. The specific factors that needed to be checked to achieve better use of database reports in the organization include; user commitment in giving necessary information to help in reviewing reports, the developers' attitude about the user's ability to propose modifications on the reports, management commitment in providing financial and non financial help in the review and revision of reports.

The original reports having been based on an existing conceptual model of another franchise organization, user involvement at that initial stage was minimal. User involvement only came in to shape the reports in an effort to meet the information needs of the users based on the limitations they faced while using the reports. Developers' competence was found to be key to determine how well user requirements were captured and met in the developed reports and consequently how much database reports were used in the organization. Management support having an influence on the amount of financial resources available and which also contributed to determine the level of expertise that was put to use in the design and development of the reports was found to influence the quality of reports and consequently the level of use of the database

reports. Other than financial support, management support extended to include other influence that management could exert on the processes of the design and development of organization's reports like tactful supervision of the design and development progress and internal personnel management relevant in the design and development processes of the reports that had an influence on the level of use of database reports.

It was found that generation of reports by users for use in the organization was not regular despite the fact that the organization's reports were categorized on the basis of how regular they were supposed to be generated i.e. daily, weekly, monthly, quarterly and yearly. Generation of the reports therefore depended on the need for certain information on reports by the users rather than at the expected end of a specific period. It was therefore clear that a regular pattern in the generation of reports would be essential so as to maximize utilization of report information. Promptness in the report generation processes influenced the use of database reports and speedy generating of database reports led to timely utilization of information. Format of generated reports also influenced the level of use of the generated reports and diversity of report formats was necessary to increase the usability of reports in the available diverse report formats. Such output formats as printed paper reports, PDA compatible reports and other mobile devices were suitable for reports users who work away from the organization's premises, in places where desk top computers and laptops cannot be used for long hours because of poor power storage capability. The mode of administration of the report generation processes influenced the status in the use of database reports. The mode of administration of the report generation processes was self-administration and report users determined when to generate reports or when reports were to be generated for them. This eliminated involvement of extra human resources in report generation. It was

however found that a different mode of administration where an autonomous party administered report generation could be advantageous since it eliminate laziness to generate database reports and help report users that lacked knowledge on report generation. It also could make report generation more organized and lead to better utilization of infrastructural resources since generation could be done at night when the network infrastructure is not congested.

It was found that the medium of distribution of reports in the organization was a local area network. This medium was reported to be an appropriate medium for report distribution because it enabled all report users anywhere in the organization to access reports easily and quickly as long as they had a connection to the server via the network. It was however found that the occasional failures of the network system at the time of initiating report distribution was a limiting factor in the delivery of highly needed reports for use. Efforts to minimize the level of downtime of the network system was critical to ensure availability of the report system for report generation and this in turn would enhance the overall use of enterprise report for management decision making. The mode of distribution of reports in the organization was found to be self-administration. This mode was found to be suitable as it did not require any intermediary to facilitate its distribution and hence the distribution was hastened. However, this processes needed to be assessed to ensure that report users access or deliver to themselves reports and use them when they are due.

User involvement throughout the process of review and revision could not be adequate as report users were not extensively consulted on changes they wished to be reflected on reports. Developers' competence was found to be critical to determine how well reports were reviewed and revised and it was found that more competence in the review and revision of reports could lead to high quality reports. Just like in design and development

of reports, management support having an influence on the amount of financial resources available and which also contributed to determine the level of expertise that was put to use in the review and revision of the reports was found to influence the quality of reports. Other than financial support, it was found that management support extended further to include other influence that management could exert on the processes of the review and revision of organization's reports like; tactful supervision of the review and revision progress and internal personnel management relevant in the review and revision processes of the reports.

#### ***Key Performance Indicators in the use of database reports in the organization***

It was found that the key things to be tracked to enhance the design and development of reports and consequently the use of the developed database reports include; percentage number of relevant users consulted during the design and development of reports, the level of relevant competence of the developers of reports, the level of management support in the design and development of reports. The key things to be tracked to improve the generation of reports and consequently the use of the generated database reports include; the level of satisfaction of the promptness of report generation, the level of satisfaction of the format of generated reports, the level of satisfaction of the mode of administration of report generation. The key things to be tracked to enhance the distribution of reports and consequently the use of the delivered database reports include; the level of satisfaction of the medium of report distribution and the level of satisfaction of the mode of report distribution. The key things to be tracked to enhance the review and revision of reports and consequently the use of the revised database reports include; percentage number of relevant report users consulted during the review of reports, the level of relevant competence of the developers of database reports and the level

of management support in the review and revision of database reports.

Findings indicated that systematic tracking of KPIs could assist in making decisions about possible adjustments to involve more and relevant report users to facilitate better design and development of reports. It could assist in taking appropriate actions in the involvement of the right persons in the design and development of reports, sensitizing the management on what could be done to support the processes of design and development of reports among others. The parameters to be tracked include, but not limited to; proportions of relevant report users consulted during the design and development of reports, the level of relevant competence of the developers of reports, the level of management support in the design and development of reports, level of satisfaction of the frequency of report generation, the level of satisfaction of the promptness of report generation, the level of satisfaction of the format of generated reports, the level of satisfaction of the mode of administration of report generation, the level of satisfaction of the medium of report distribution, and the level of satisfaction of the mode of report distribution, proportions of relevant report users consulted during the review and revision of reports, the level of relevant competence of the developers of reports and the level of management support in the review and revision of reports.

### **Conclusion and Future Work**

In the light of this research, it can be seen that electronic reports being the most popularly used of all the cited electronic information resources in the organization indicate the influence of reports in management decision making. This emphasized the need to step up utilization of them through improving the electronic data depositories such as databases, data warehouses, files and all kinds of electronic data sources that are capable of providing information to reporting systems. The level of utilization of reports is influenced by factors related to the design, development,

generation, distribution, review and revision of reports. This implies that at each stage of the report cycle the overall efficiency of reporting systems is influenced and it is therefore necessary for each of the stages of the cycle to be improved for overall improvement in the use of reporting systems. The challenges facing use of database reports are controllable if identified and dealt with. Since the amount of relevant information possessed by decision makers is a critical aspect of efficient decision making, it implies that information about the use of database reports can be tracked and necessitate action from different relevant persons in the organization. The information about use of reporting systems can be tracked and presented by use of a supervision reporting system, and the indicators of the status in the use of reporting in the organization would be help to facilitate action from the responsible persons in the organization.

The study recommends that in order to derive the right information from the organization's electronic data resources, there is a need for the Information Technology department to improve the storage mechanisms of data in the organization for ease of access through data warehousing. Also, in order to tap the influence of employees to promote the use of business intelligence tools, there is need for the Information Technology department to facilitate training to report users and other relevant persons on their role in the different aspects of business intelligence tools. In order to improve the effectiveness of the use of database reports in the organization, there is a need for the top management of the organization to grow the Information Technology department to possess diverse skills relevant to business intelligence such as programming, data warehousing, and database administration among others. In order to provide useful information to the relevant persons in the organization to enhance taking of an appropriate action and promoting use of Business intelligence tools in the organization. There is need for the Information Technology department to

adopt a supervision reporting system such as the one developed in the study for tracking the critical aspects of the reporting. In order to promote the use of business intelligence tools, there is a need for policy formulation and implementation by the Information Technology department relating to design and development of reports, generation of reports, and distribution of reports, review and revision of reports.

This paper proposes a research on the cost evaluation of business intelligence services in the soft drinks industry and in other organizations would give a true reflection of the value of Business Intelligence.

### Limitations of the study

The study was limited in a number of ways as it focused on one player in the soft drinks industry in Nyanza province, Kenya. The findings may therefore only be generalized with caution across other organisations and which implies that another study should be done using a more representative sample population so that the findings can be generalized across all companies in the soft drinks industry and outside the industry. The developed model can be used as a solution to the practical challenges facing use of business intelligence in organizations.

### References

**Anandarajan, A. and Wen, H. J.** (1999). Evaluation of Information Technology Investment. *Management Decision*, 37(4), 329-337.

**Bakos, Y. J.** (1995). Are Computers Boosting Productivity? Yes! *Computer world* 29(13), 129.

**Baskerville, R. and Wood-Harper, A. T.** (1998). Diversity in information action research studies. *European Journal of Information Systems*, 7, 90-107.

**Brynjolfsson, E.** (1993). The Productivity Paradox of Information Technology. *Communications of the ACM* 36(12), 67-77.

**Business Daily Africa - the international window into East African business opportunities - Coca-Cola invests Sh3bn**

**to expand production.** *Business Daily* (2008). [http://www.bdafrica.com/index.php?option=com\\_content&task=view&id=7529&Itemid=5822](http://www.bdafrica.com/index.php?option=com_content&task=view&id=7529&Itemid=5822). 16 September 2008.

**Business Objects Enterprise. Business Objects** (2002). [http://www.businessobjects.com/products/bi\\_deployment.htm](http://www.businessobjects.com/products/bi_deployment.htm). 01 August 2008.

**Business Technology Group.** (2008). How are Balanced Scorecards and Dashboards Different? <http://www.dmreview.com/news/10001076-1.html>. 15 September 2008.

**Darrow, B.** (2003). Making the Right Choice - Solution providers are evaluating a plethora of options as they puzzle over the future of business intelligence. *Computer Reseller News*, 03 July 2003.

**Davern, M. and Kauffman, R.** (2000). Discovering Potential and Realizing Value from Information Technology Investments. *Journal of Management Information Systems Spring*, 121-143.

**Earl, M. J.** (1993). Experiences in Strategies for Information Technology. *MIS Quarterly*, 17 (1), 1-24.

**Galliers, R.D.** (1994). Choosing Information Systems Research Approaches. in R.D.Galliers (ed) *Information System Research: Issues, Methods, and Practical Guidelines*, Blackwell Science, Oxford, 144-162.

**Gregory Hill. Enterprise Reporting.** (2008). Definition. <http://ghill.customer.netspace.net.au/reporting/definition.html>. 15 July 2008.

**Information Week - Enterprise Reporting Makes A Comeback.** (2008). Business Intelligence InformationWeek Hp. [http://www.informationweek.com/news/business\\_intelligence/showArticle.jhtml?articleID=16100762](http://www.informationweek.com/news/business_intelligence/showArticle.jhtml?articleID=16100762). 15 July 2008.

**Marcus G., Arnott D., Ilona J.** (2004). Evaluating the Intangible Benefits of Business Intelligence: Review and Research Agenda. Hp. 2004. [http://s-cah-vishnu.infotech.monash.edu.au/dss2004/proceedings/pdf/29\\_Gibson\\_Arnott\\_Jagielska.pdf](http://s-cah-vishnu.infotech.monash.edu.au/dss2004/proceedings/pdf/29_Gibson_Arnott_Jagielska.pdf) . 13 June 2009.



- Money, A., and Tromp, D.** (1988). The Quantification of Decision Support Benefits within the context of Value Analysis. *MIS Quarterly* 12 (2), 223-236.
- Tallon, P., Kraemer, K., et al.** (2001). Executives Perceptions of the Business Value of Information Technology: *A Process-Oriented Approach*. Irvine, CA, Center for Research on Information Technology and Organizations, Graduate School of Management.
- Whitehorn, M. and Whitehorn, M.** (1999). Business Intelligence: The IBM Solution, Datawarehousing and OLAP. London, Springer-Verlag.

# Bandwidth Enhancement of a Circular Microstrip Patch Antenna through Shape Modification in the S-Band

By

<sup>1</sup>Kipkorir Langat, B. K. \*, <sup>1</sup>Langat, K. P., <sup>1</sup>Musyoki, S.

<sup>1</sup>Department of Telecommunication and Information Engineering, Jomo Kenyatta University of Agriculture and Technology (JKUAT), Nairobi, Kenya.

\*Corresponding author: [engineer.langatben@yahoo.com](mailto:engineer.langatben@yahoo.com)

---

## Abstract

An antenna is a crucial component of a communication system. Many applications require a small, light-weight and cheap antenna that can easily fit to the surface it is attached. All these features are characteristic of microstrip patch antennas. However, microstrip patch antennas have their own disadvantages such as low radiation efficiency, low power, high Q, low Gain and very narrow frequency bandwidth. The main aim of this study was to improve the narrow bandwidth of a circular microstrip patch antenna through shape modification. An initial circular patch of radius 2.85cm was designed at a center frequency of 2GHz using RT/Duroid 5880 substrate with a dielectric constant of 2.2 and height of 0.1575cm. Efforts were then made to improve its bandwidth by removing some parts from the initial circular patch. Other important parameters of the antenna such as radiation efficiency, impedance matching and Gain are not degraded in the process of improving the bandwidth of a microchip patch antenna. The antenna was fed by a microstrip line feed and simulated and analyzed using HFSS 13.0 software. Simulation results of return loss ( $S_{11}$  parameters), Smith chart of S-parameters,  $Z_{11}$  parameters, VSWR, Gain and radiation efficiency will be presented. The results of  $S_{11}$  parameters showed that the modified circular microstrip patch antenna achieved an improved bandwidth as compared to the initial circular microstrip patch antenna. There was also good impedance matching with a  $50\Omega$  line as reflected by the results of  $Z_{11}$  parameters.

**Key words:** Bandwidth enhancement, circular microstrip patch antenna, shape modification, simulation.

---

## Background

An antenna serves to a communication system as a structure for radiating or receiving radio waves. Based on the two functions, there are transmitting and receiving antennas. Many types of antennas are in existence such as horn, reflector, wire, aperture, microstrip and so forth [1]. Each type of antenna has its own advantages and

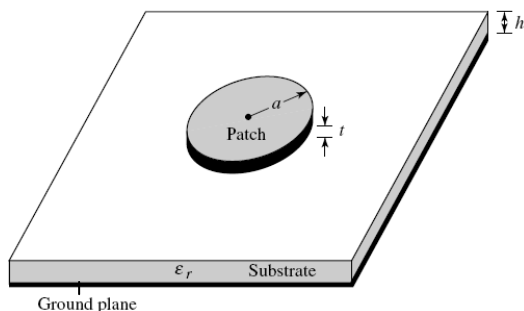
disadvantages. The disadvantages of an antenna degrade the performance of the antenna by lowering its efficiency and effectiveness. Though it is difficult to achieve a perfect antenna with totally no drawback, a great deal of antenna research is on alleviating drawbacks associated with each type of antenna. The main overall goal is to achieve an antenna which is light in weight,

cheap, small in size and can operate over the whole frequency band of a given system (Balanis, 2005).

Microstrip patch antennas are inherently light in weight, small in size and cheap. However, they also have disadvantages such as low radiation efficiency, low power, high Q (sometimes in excess of 100), poor polarization purity, poor scan performance, spurious feed radiation, and very narrow frequency bandwidth. The desirable features of microstrip patch antennas make them suitable for many applications at microwave frequencies. They find applications in high performance aircraft, spacecraft, satellite and missile applications (Balanis, 2005).

Microstrip patch antenna is made up of a radiating metallic patch on top of a dielectric substrate and a ground plane at the bottom of the dielectric substrate. The metallic patch can take different shapes such as square, rectangular, dipole, circular, elliptical, triangular, disc sector, circular ring, ring sector and so on. The shape of the radiating patch gives the name of microstrip patch

antennas. For example, rectangular and circular microstrip patch antenna. Of the many shapes that can be used, square, rectangular, dipole and circular microstrip patch antennas are common because they are easy to design and analyze and have low cross-polarization radiation (Balanis, 2005). Circular microstrip patch antenna is more convenient to design compared to rectangular one. In addition, the radiation properties of a circular microstrip patch antenna can easily be controlled. This is because circular microstrip patch antenna has one degree of freedom to control (radius) while the rectangular one has two (length and width) (Huque *et al.*, 2011). Moreover, the physical size of the circular patch is 16% less than that of the rectangular one at the same design frequency (Garg *et al.*, 2001). Because of the added advantages of circular microstrip patch antennas as compared to rectangular ones, the focus of this study will be on circular microstrip patch antenna. The physical structure of a circular microstrip patch antenna is illustrated in Figure 1 (Balanis, 2005).



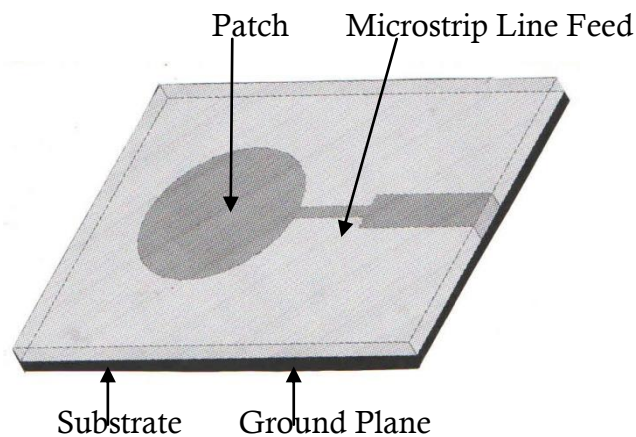
**Figure 1. Circular Microstrip Patch Antenna**

The thickness of the circular metallic patch,  $t \ll \lambda_0$  (where  $\lambda_0$  is free space wavelength). The height of the substrate is also much less than free space wavelength,  $h \ll \lambda_0$ . This is usually in the range  $0.003 \lambda_0 \leq h \leq 0.05 \lambda_0$ . Numerous substrates exist that can be used to design microstrip patch antennas. Each substrate has a unique dielectric constant. The dielectric constants of the common substrates range between 2.2 and 12 (Balanis, 2005). In order to achieve better efficiency, larger bandwidth and loosely bound fields that can easily be radiated into space, thick substrates with low dielectric

constants are desirable. However, the element size becomes larger as substrate height increases. Conversely, microwave circuitry requires thin substrates with high values of dielectric constants in order for the element sizes to be smaller. They will also produce tightly bound fields thus minimizing undesired radiation and coupling. The problem is that the device will experience high losses that in turn lower the efficiency. Thin substrate with high values of dielectric constants also results in smaller bandwidths (Pozar, 1992).

There are a number of methods that can be used to deliver electrical energy to the radiating patch. Some involve direct contact with the radiating patch while others utilize

electromagnetic field coupling. The popular ones are microstrip line, coaxial probe, aperture coupling and proximity coupling (Balanis, 2005; Waterhouse, 2003).

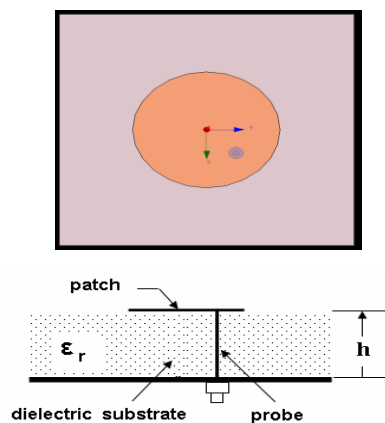


**Figure 2. Microstrip Line Feed for a circular microstrip patch antenna**

Microstrip line feed consists of a very narrow conducting strip that directly connects to the radiating patch (Figure 2). This feeding scheme is easy to construct, easy to match and somehow easy to model. However, surface waves and spurious feed radiation

increases as substrate height increases. This in turn limits the bandwidth to 2-5% (Balanis, 2005; Waterhouse, 2003).

Figure 3 Structure of a coaxial line feed for a circular microstrip patch antenna.

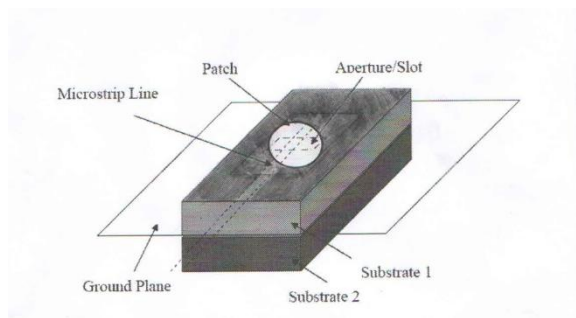


**Figure 3. Structure of coaxial line feed for a circular microstrip patch antenna (Probe Feed)**

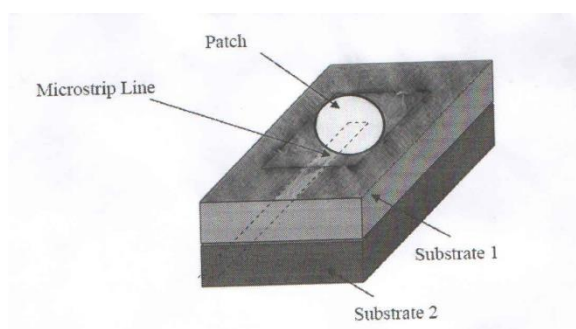
In a coaxial line feeding scheme, in Figure 3, a coaxial transmission line is used. The inner conductor of the coax is directly connected to the radiating patch whereas the outer conductor is attached to the ground plane. It is easy to construct and match and has low spurious radiation. However, it is more difficult to model in thick substrates with narrow bandwidth ( $h > 0.02 \lambda_0$ ) (Balanis, 2005; Waterhouse, 2003). In an aperture

coupled feeding scheme (Figure 4), electromagnetic field coupling is utilized to couple energy from the feed line to the radiating patch. It is made of two substrates with a ground plane in between them. The feed line is situated at the bottom of the lower substrate and its energy is coupled to the patch through an opening on the ground plane. It is possible to optimize the feed and the patch independently in aperture coupled

feed. It is not so complex to model and has moderate spurious radiation. However, it has narrow bandwidth and is the most difficult to fabricate (Balanis, 2005; Waterhouse, 2003).



**Figure 4. Structure of aperture-coupled feed**



**Figure 5. Proximity-coupled feed (electromagnetic coupling scheme) for a circular microstrip patch antenna**

Aperture coupled feed in Figure 5, utilize electromagnetic field coupling to couple energy to the radiating patch. It has two substrates. The feed line is located between the two substrates while the radiating patch is located at the top of the upper substrate resulting in a bandwidth of up to 13%. It is a bit easy to model, and has low spurious radiations but difficult to fabricate (Balanis, 2005; Waterhouse, 2003). Microstrip line feed is easy to fabricate, match and model (Balanis, 2005) making a good choice for this study. For the analysis of electromagnetic field behavior of microstrip patch antennas, transmission line model, cavity model and full wave model are the common models that can be utilized. Full wave model is the most accurate and flexible of the three (Balanis, 2005). Therefore, HFSS 13.0 software based on a full wave model was used in this study.

**Problem statement and justification**

In designing antennas, an antenna designer aims to produce an antenna, which is small in size, easy to fabricate, cheap, broadband, and easily integrated with monolithic microwave integrated circuits (MMIC) (Mitra, 2012). Since no antenna possess all the features in its conventional form, it is easy to start with an antenna that possess most of the features and look for ways of alleviating associated shortcomings. Microstrip patch antenna is one type of antenna that possesses most of the features. However, one of the major disadvantages of microstrip patch antennas is narrow bandwidth (Waterhouse, 2008). Conventional microstrip patch antennas achieve an impedance bandwidth of less than 3% of the centre frequency (Pozar and Schaubert, 1995).

In order for microstrip patch antennas to be more competitive, there is a need to come up

with ways of alleviating their major disadvantages. There are many methods that have been reported in the literature to improve the narrow bandwidth of microstrip patch antennas. The method of shape modification is easy and does not result in extra weight of the microstrip patch antenna as described in this study. Cutting out some parts from it modified the shape of the initial circular microstrip patch. The bandwidth achieved by the modified circular microstrip patch antenna was compared with the bandwidth of the initial circular microstrip patch antenna. The simulation process was carried out using HFSS 13.0 software.

### Antenna parameters used in the analysis

The simulated microstrip patch antennas were analyzed based on the following properties:

#### Return loss

Return Loss, RL, ( $S_{11}$ ) parameter is a measure of power that is reflected from an antenna. It is a measure of the extent the antenna line feed is matched with the antenna (Huang and Boyle, 2008). Since it is difficult to achieve a perfect antenna with a Voltage Standing Wave Ratio (VSWR) of 1:1, a VSWR of 2:1 has been found to be satisfactory for practical antennas. RL of an antenna with a VSWR of 2:1 is found to be 9.5424 dB based on equation 1 below. Therefore, -9.5424dB point is used to determine the impedance bandwidth of an ant

$$RL = 20 \log \left[ \frac{VSWR+1}{VSWR-1} \right] \quad (1)$$

### Circular microstrip patch antenna geometry

The main aim of this study was to improve the bandwidth of a circular microstrip patch antenna through shape modification. Therefore, the simulated results of the modified circular microstrip patch antenna had to be compared with those of the initial circular microstrip patch antenna in order to

Smith chart of  $S_{11}$  parameter provides information concerning polarization and impedance matching that occur between the antenna and the transmission line. The impedance curve touching the unitary circle of the smith chart indicates a good match between the antenna and the transmission line. The radius of the impedance circle gives the polarization factor of the antenna.

### Z-parameters

The most important Z-parameter component of antennas is  $Z_{11}$  (Input Impedance). It is used to determine the impedance matching of the antenna with that of the transmission line. The impedance of an antenna should be real at resonance. Therefore the real part of  $Z_{11}$  parameters should be equal to the characteristic impedance of the transmission line at the resonant frequency. On the other hand, the imaginary part should be equals to zero at the resonant frequency.

### Gain

Gain of an antenna in a given direction is the ratio of the intensity, in a given direction, to the radiation intensity that would be obtained if the power accepted by the antenna were radiated isotropically (Balanis, 2005). The Gain of microstrip patch antennas is typically less than 8dBi (Waterhouse, 2003).

### Radiation efficiency

Antenna radiation efficiency is the ratio of the power radiated by the antenna to the total power input to the antenna (Bakshi and Bakshi, 2009). Typical radiation efficiency of microstrip patch antennas is between 70% and 90% (Bansal, 2004).

determine the improvement in bandwidth that was achieved. The initial circular microstrip patch antenna was designed at a center frequency of 2GHz using RT/Duroid 5880 substrate with a dielectric constant of 2.2 and substrate height of 0.1575cm. Its radius was found to be 2.85cm by using the design equation of circular microstrip patch antenna below:

$$a = \frac{F}{\left\{1 + \frac{2h}{\pi F \epsilon_r} \left[ \ln\left(\frac{\pi F}{2h}\right) + 1.7726 \right] \right\}^{1/2}} \quad (2)$$

$$F = \frac{8.791 \times 10^9}{f_r \sqrt{\epsilon_r}} \quad (3a)$$

In this equation,

$f_r$ - Resonant frequency

$\epsilon_r$  -Dielectric constant of substrate

h- Height of substrate

a- Radius of the patch

The width of the microstrip line feed greatly affects the impedance matching between the transmission line and the microstrip patch antenna. The width of the microstrip line feed,  $W_f$ , that can easily achieve good impedance matching is determined by equation below.

$$Z_0 = \begin{cases} \frac{60}{\sqrt{\epsilon_r}} \ln\left(\frac{8h}{W_f} + \frac{W_f}{4h}\right) & \text{for } \frac{W_f}{h} \leq 1 \\ \frac{120\pi}{\sqrt{\epsilon_r} \left[ \frac{W_f}{h} + 1.393 + 0.667 \ln\left(\frac{W_f}{h} + 1.444\right) \right]} & \text{for } \frac{W_f}{h} \geq 1 \end{cases} \quad (3b)$$

But if the characteristic impedance,  $Z_0$ , and the dielectric constant,  $\epsilon_r$ , are known, the ratio of  $\frac{W_f}{h}$  is obtained using the equations below.

$$\frac{W_f}{h} = \begin{cases} \frac{8e^A}{e^{2A} - 2} & \text{for } \frac{W_f}{h} < 2 \\ \frac{2}{\pi} \left[ B - 1 - \ln(2B - 1) + \frac{\epsilon_r - 1}{2\epsilon_r} \left\{ \ln(B - 1) + 0.39 - \frac{0.61}{\epsilon_r} \right\} \right] & \text{for } \frac{W_f}{h} \geq 2 \end{cases} \quad (4)$$

$$A = \frac{Z_0}{60} \sqrt{\frac{\epsilon_r + 1}{2} + \frac{\epsilon_r - 1}{\epsilon_r + 1}} \left( 0.23 + \frac{0.11}{\epsilon_r} \right) \quad (5)$$

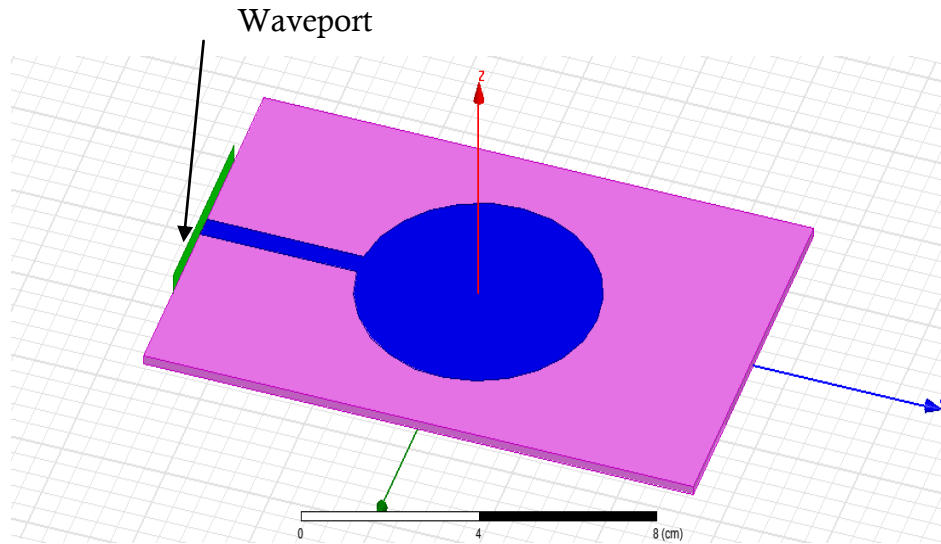
and

$$B = \frac{377\pi}{2Z_0\sqrt{\epsilon_r}} \quad (6)$$

By utilizing equation 4 for  $\frac{W_f}{h} \geq 2$ , microstrip line feed width of 0.4853cm was found to be suitable for this design for a  $50\Omega$  transmission line. However, for easy implementation of the simulated antenna, microstrip line feed width of 0.5cm was used.

### Simulation of the initial circular microstrip patch antenna

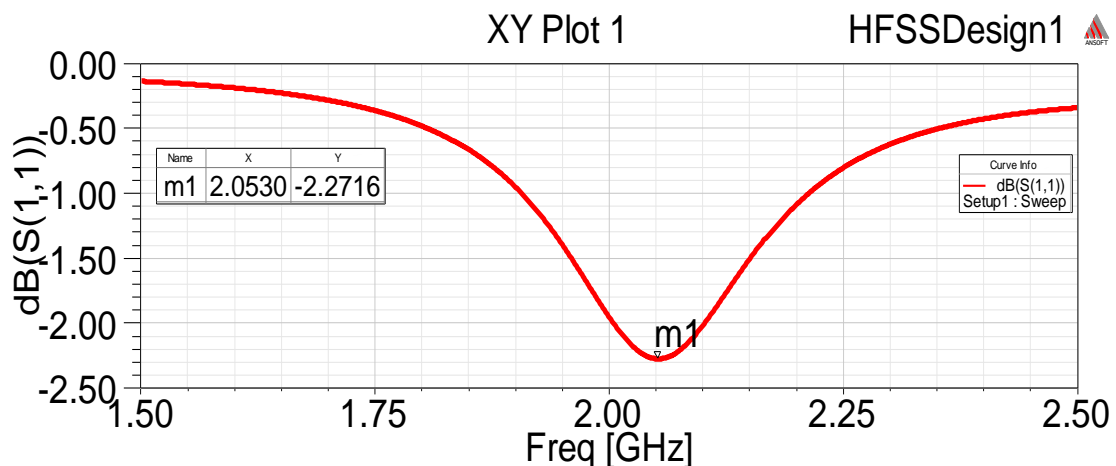
The geometry of the initial circular microstrip patch antenna is shown in figure 6 below.



**Figure 6. Initial circular microstrip Patch Antenna**

The dimensions of the substrate were 13.2cm×8.7cm×0.1575cm. The substrate used was RT/Duroid 5880. The radius of the patch was 2.85cm while the microstrip line feed had a length of 3.75cm and width of 0.5cm. The waveport had a width of 4.4cm and height of 0.5cm.

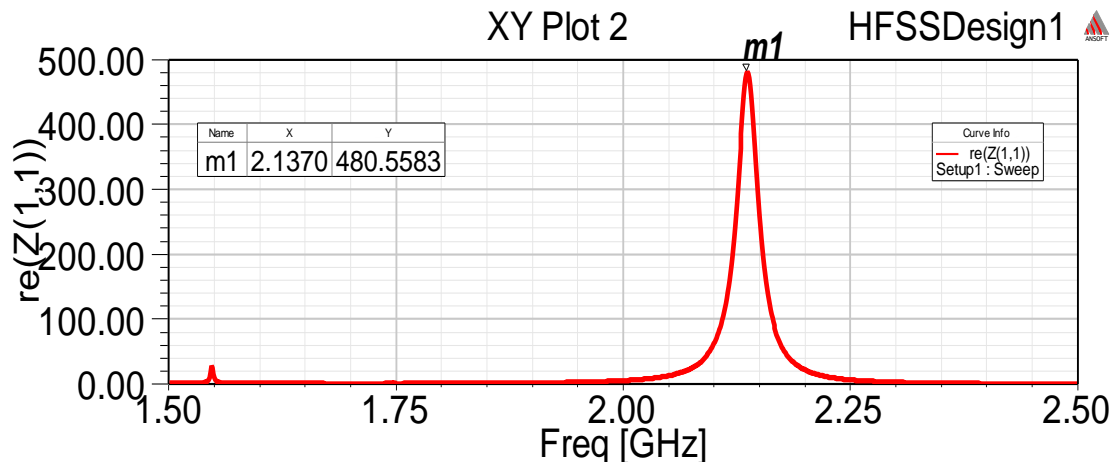
The antenna was simulated and analyzed at a centre frequency of 2GHz over the frequency range 1.5GHz-2.5GHz using HFSS 13.0. Simulation results were then presented.



**Figure 7. Return Loss ( $S_{11}$  Parameters) versus Frequency**

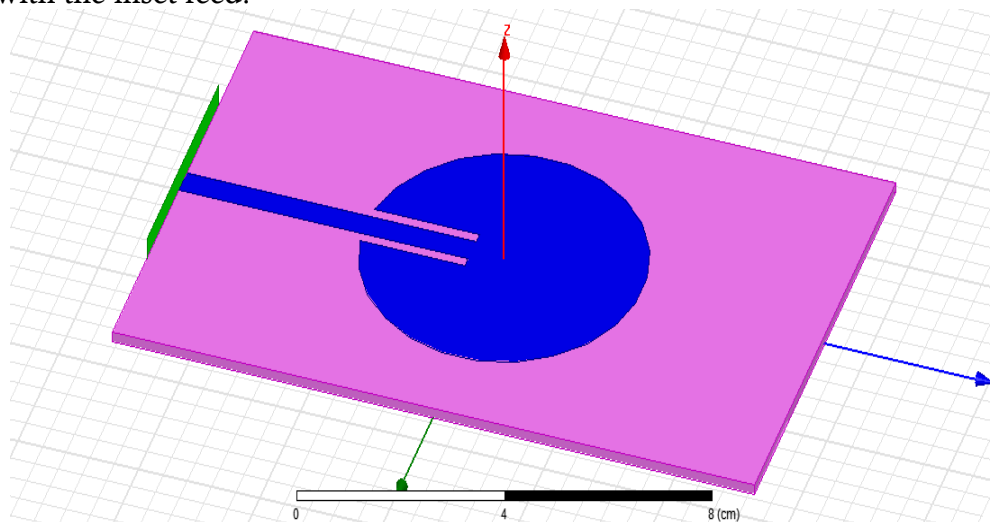
The simulated results of  $Z_{11}$  parameters was also as shown in figure 8 below.





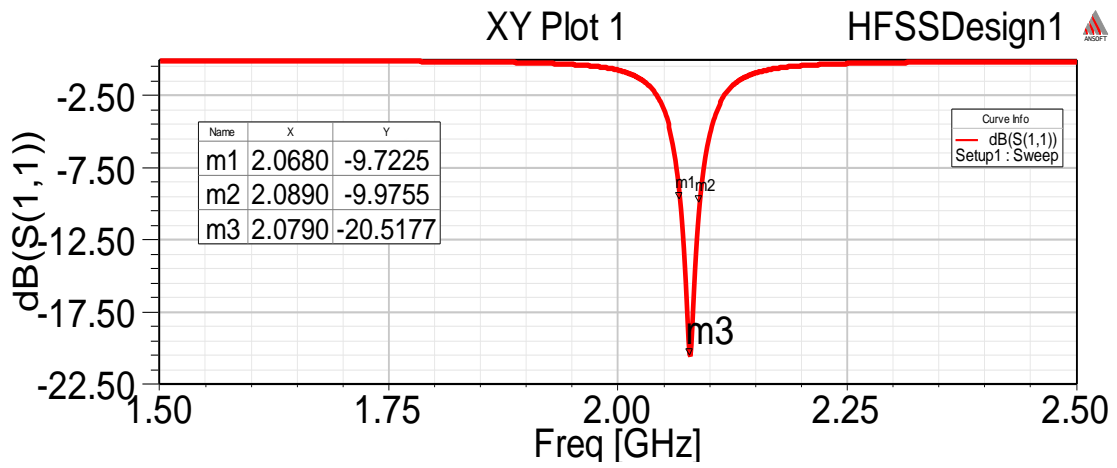
**Figure 8. Real Part of  $Z_{11}$  Parameters versus Frequency**

The result of RL indicates that the curve was not able to cross -9.5424dB point. This indicates that the antenna did not achieve good impedance matching. The same is indicated by the results of  $Z_{11}$  parameters. The impedance at resonance was  $480.6\Omega$  indicating a great mismatch with  $50\Omega$  transmission line. In order to improve the impedance matching, an inset feed was introduced. An inset feed of width 0.2cm recessed a distance of 2.2cm from the edge of the patch was used. Figure 9 below shows the initial circular microstrip patch antenna with the inset feed.

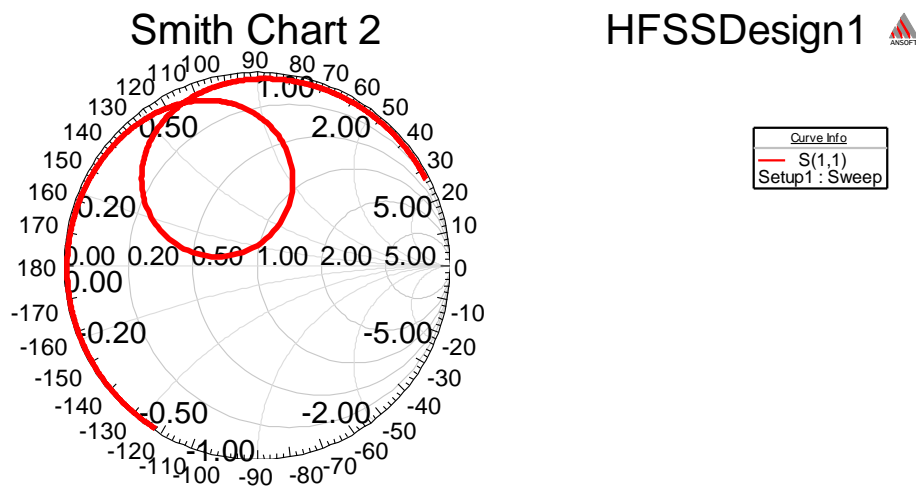


**Figure 9. Initial Circular Microstrip Patch Antenna with Inset Feed**

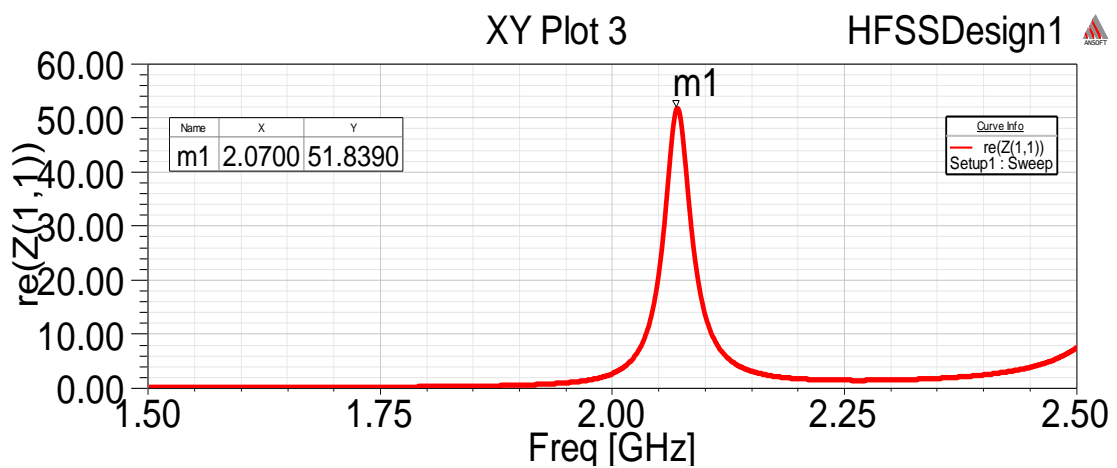
Simulation results of the initial circular microstrip patch antenna with the inset feed were as shown in the figures below.



**Figure 10. Return Loss ( $S_{11}$  Parameters) versus Frequency**



**Figure 11. Smith Chart of  $S_{11}$  Parameters**



**Figure 12. Real Part of  $Z_{11}$  Parameters versus Frequency**

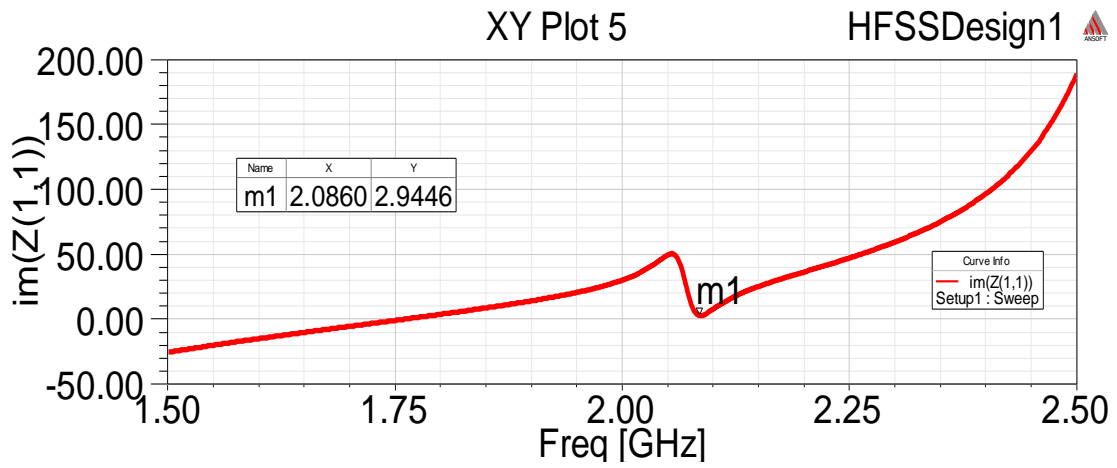


Figure 13. Imaginary Part of  $Z_{11}$  Parameters versus Frequency

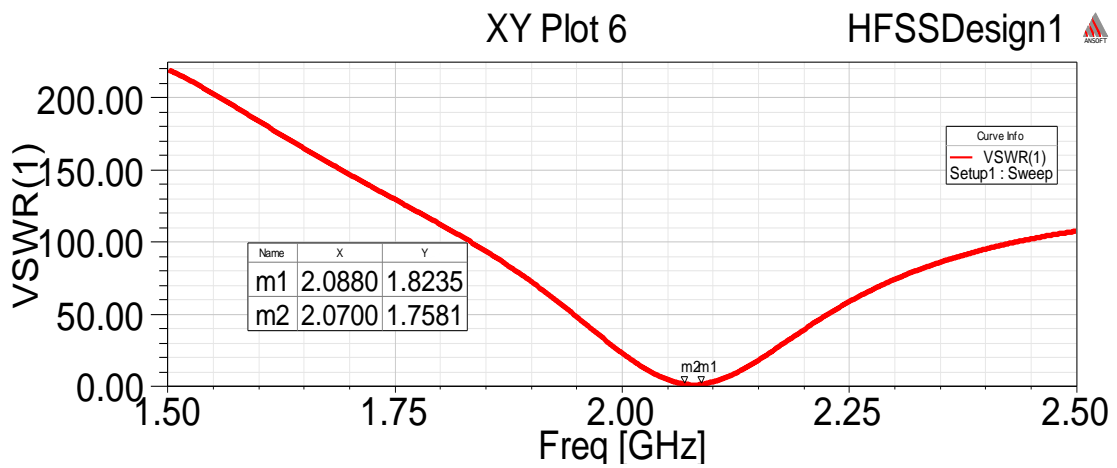


Figure 14. VSWR versus Frequency

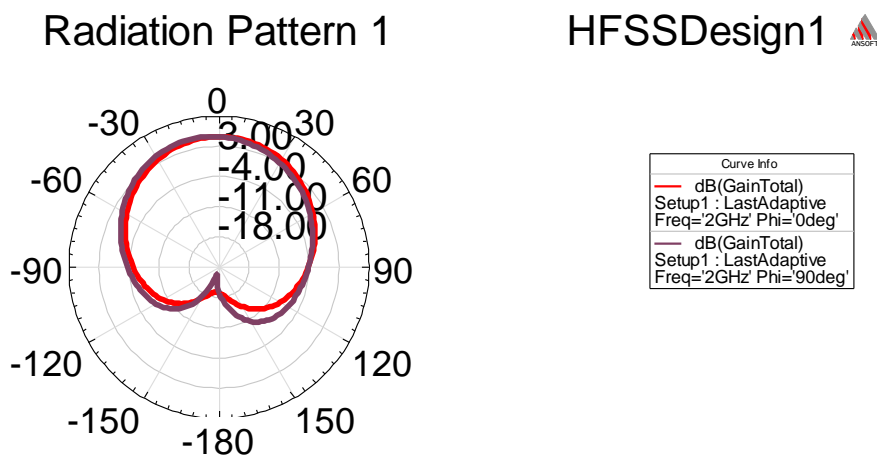


Figure 15. 3D Plot of Gain

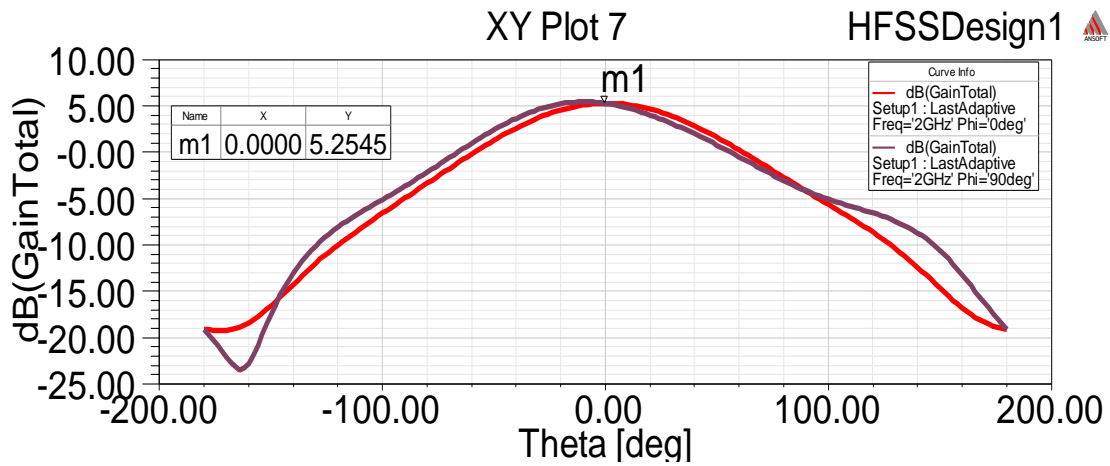


Figure 16. Rectangular Plot of Gain

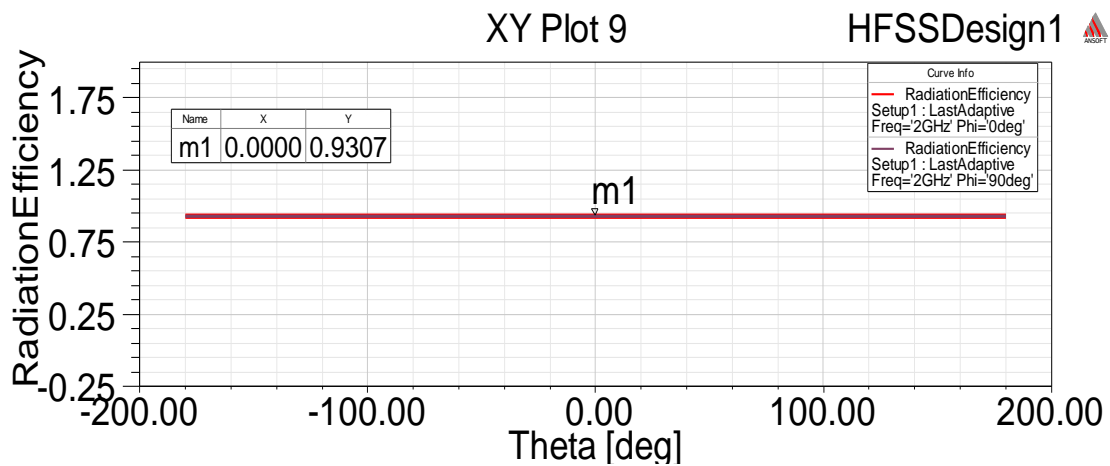


Figure 17. Radiation Efficiency

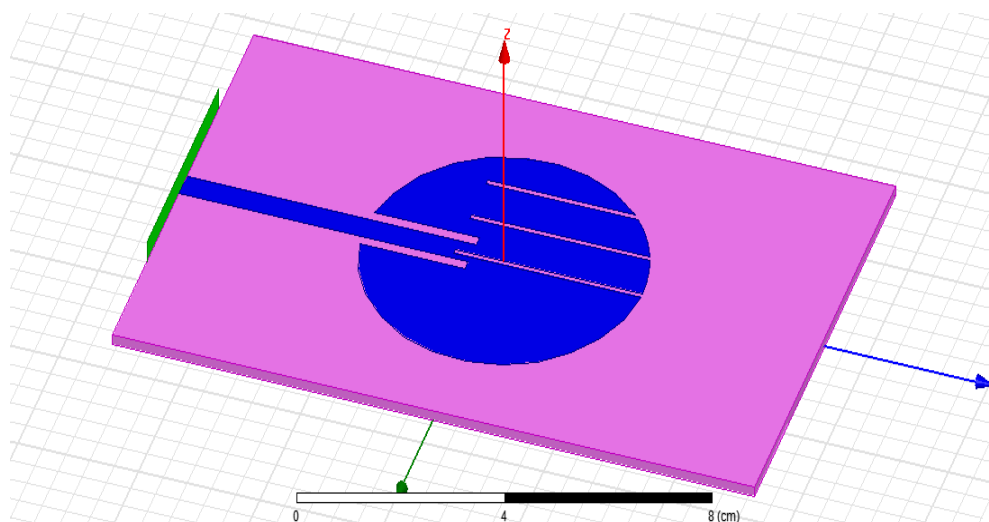
The return loss of the antenna now crosses -9.5424dB with a return loss of -20.5177dB at resonant frequency of 2.079GHz. The slight shift in the resonant frequency from the one used in the design is associated with the fact that the cavity model in which the design equation of circular microstrip patch antennas (equations 2 and 3) is based, is less accurate than the full wave model in which HFSS 13.0 is based. The impedance bandwidth of the initial circular microstrip patch antenna with the inset feed is 21MHz for return loss better than -9.5424dB. The antenna also showed a good impedance matching with a 50Ω transmission line. The impedance at resonant frequency was 51.839Ω with only a small reactance. The

VSWR of the antenna was less than 2 over the bandwidth. The antenna achieved a Gain of 5.2545dB at theta equals to zero degrees direction. The antenna also achieved good radiation efficiency of 93.07%.

### Simulation of the modified circular microstrip patch antenna

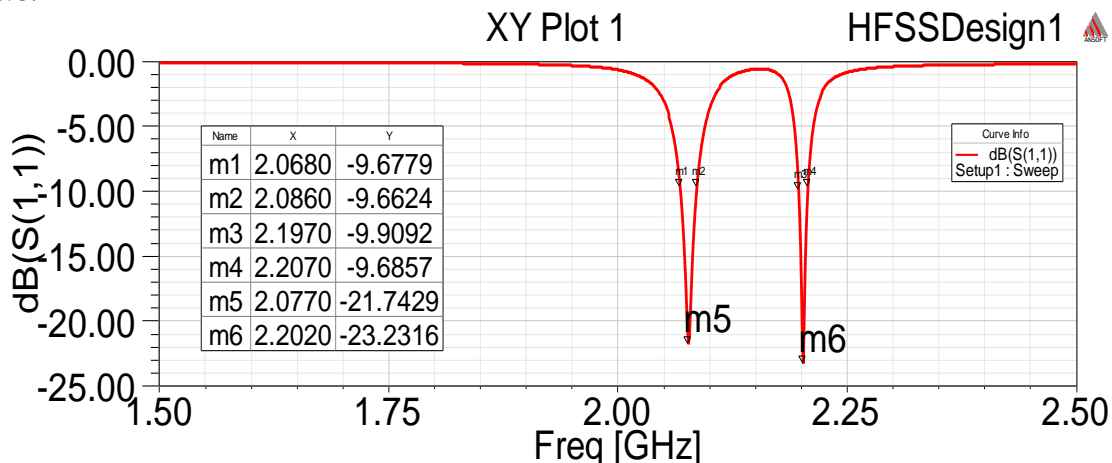
Without changing other parameters of the antenna, three narrow rectangles of width 0.1cm positioned at coordinates (-2cm,-1cm), (-1cm, -1cm) and (0cm, -1cm) with the centre of the patch reference at coordinate (0cm, 0cm) and of length 3.2cm, 3.8cm and 4cm respectively (i.e all the three rectangles extends to the edge of the patch) were cut

out from the initial circular patch as shown in figure 18 below.

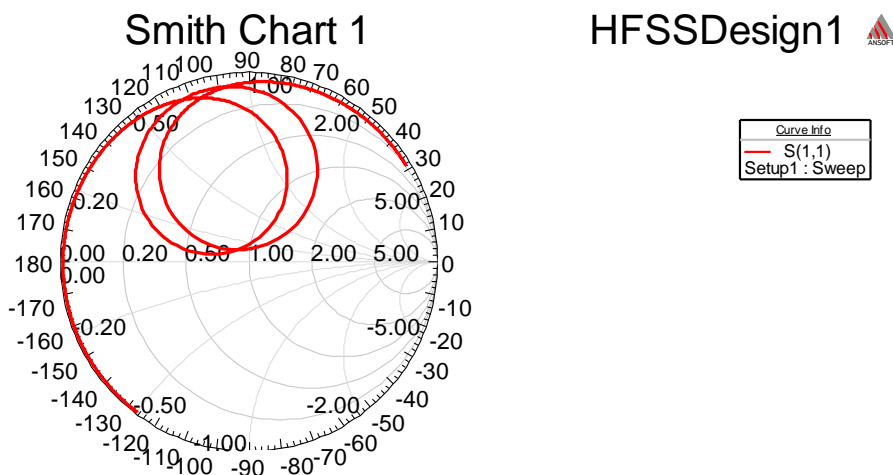


**Figure 18. Modified Circular Microstrip Patch Antenna**

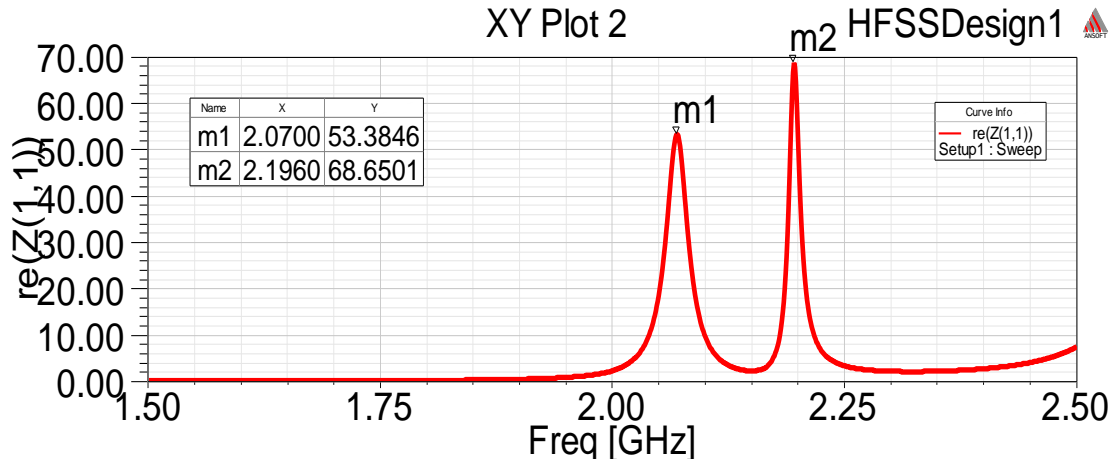
The modified circular microstrip patch antenna was simulated and analyzed at a centre frequency of 2GHz over the frequency range 1.5-2.5GHz and the simulation results were as follows.



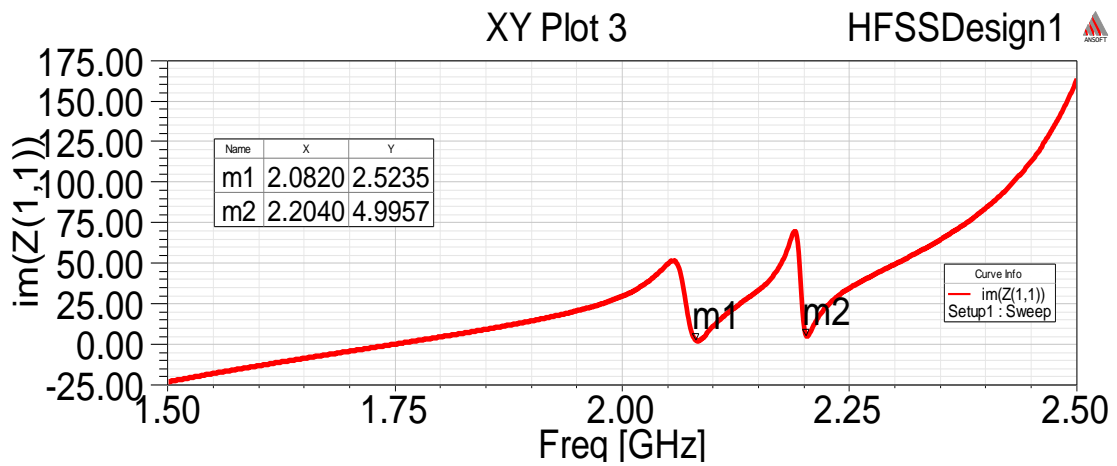
**Figure 19. Return Loss ( $S_{11}$  Parameters) versus Frequency**



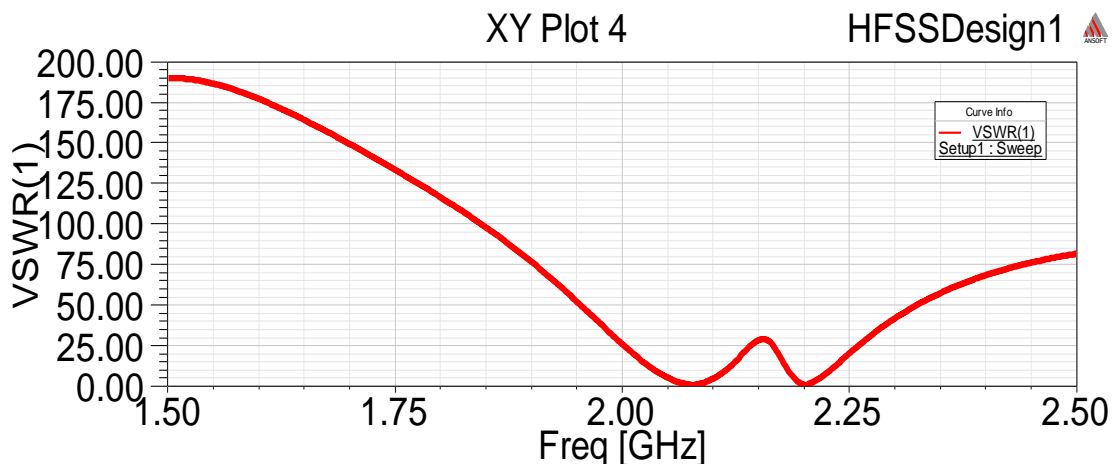
**Figure 20. Smith Chart of  $S_{11}$  Parameters**



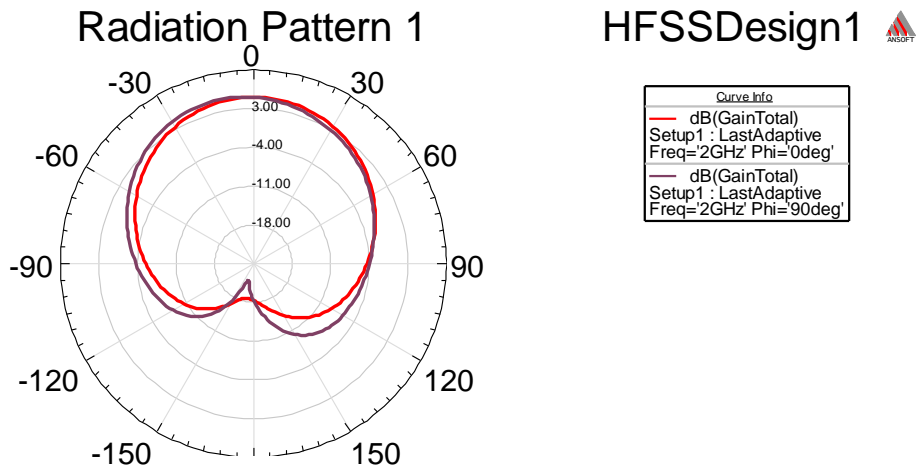
**Figure 21. Real Part of  $Z_{11}$  Parameters versus Frequency**



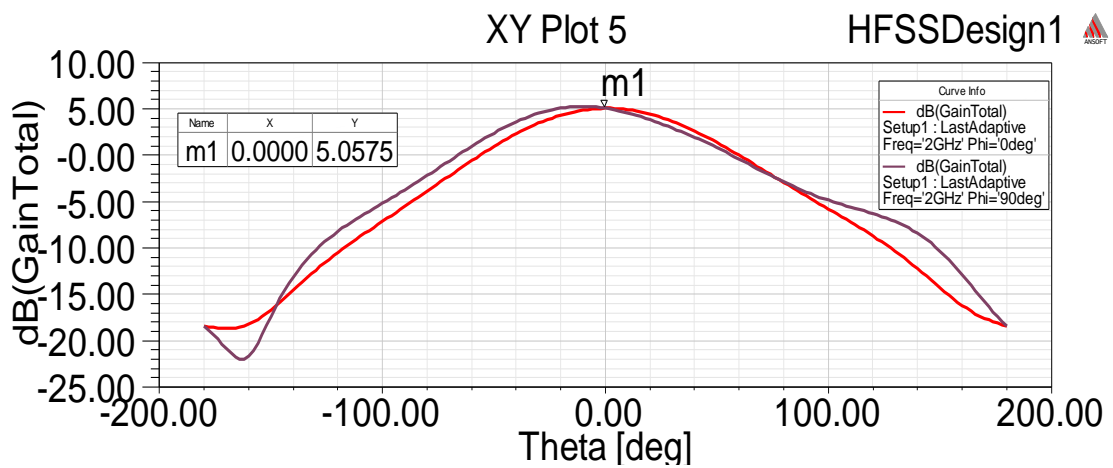
**Figure 22. Imaginary Part of  $Z_{11}$  Parameters versus Frequency**



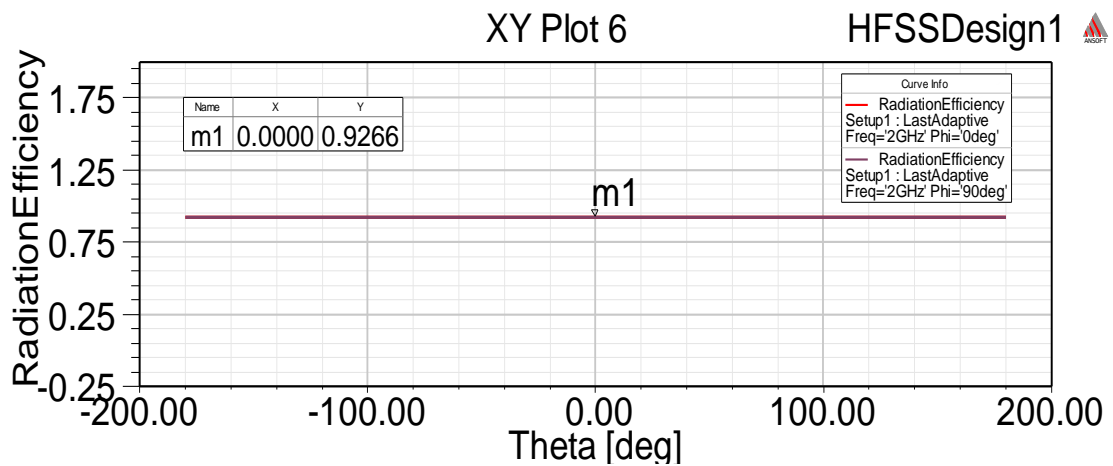
**Figure 23. VSWR versus Frequency**



**Figure 24. 3D Plot of Gain**



**Figure 25. Rectangular Plot of Gain**



**Figure 26. Radiation Efficiency**

The modified circular microstrip patch antenna resonated at 2.077GHz and 2.202GHz with bandwidth of 18MHz and 10MHz respectively for return loss better than -9.5424dB. The antenna achieved a total bandwidth of 28MHz. The return loss of the antenna was -21.7429dB in the lower band and -23.2316dB in the upper band. The impedance of the antenna was 53.3846Ω in the lower band and 68.6501Ω in the upper band. The antenna experienced only a small reactance in both of the bands. The Gain of the antenna was 5.0575dB at theta equals to zero degrees direction and radiation efficiency was 92.66%.

### Conclusion

In this study, the radiation performance of a modified circular microstrip patch antenna was simulated using HFSS 13.0 simulation software. The results obtained were compared with those of the initial circular microstrip patch antenna. The results showed that the modified circular microstrip patch antenna achieved a better bandwidth than the initial one. The modified circular microstrip patch antenna resonated at two frequencies in the S-band achieving a total bandwidth of 28MHz for return loss better than -9.5424dB. This is an improvement when compared with the bandwidth of 21MHz achieved by the initial circular microstrip patch antenna. Other parameters of the modified circular microstrip patch antenna such as  $Z_{11}$  parameters, Gain and radiation efficiency remained almost the same as those of the initial circular microstrip patch antenna. This is to say other essential parameters of the antenna were not degraded in the process of improving the bandwidth. The modified circular microstrip patch antenna presented in this study is a good candidate for further optimization to achieve greater bandwidth. The antenna will further be tuned to resonate at 2GHz since the targeted frequency is 2GHz.

### Acknowledgement

The authors would like to thank the Maseno University Conference Secretariat for taking their valuable time to go through this paper. All the valuable feedbacks and the acceptance of this paper are highly appreciated.

### References

- Balanis, C. A.** (2005). *Antenna Theory Analysis and Design*. John Wiley and Sons, New Jersey.
- Huque, M. T. I., Chowdhury, M. A., Hosain, M. K. and Alam, M. S.** (2011). Performance Analysis of Corporate Feed Rectangular Patch Element and Circular Patch Element 4×2 Microstrip Array Antennas. *International Journal of Advanced Computer Science and Applications*. Vol. 2(7).
- Garg, R., Bhartia, P., Bahl, I. and Ittipiboon, A.** (2001). *Microstrip Antenna Design Handbook*. Artech House Inc.
- Pozar, D. M.** (1992). Microstrip Antennas. *Proc. IEEE*. Vol. 80(1): 79-81.
- Waterhouse, R.** (2003). *Microstrip Patch Antennas: A Designer's Guide*, Springer.
- Mitra, D., Das, D. and BhadraChaudhuri, S. R.** (2012). Bandwidth Enhancement of Microstrip Line and CPW-Fed Assymetrical Slot Antennas. *Progress in Electromagnetic Research Letters*. 32: 69-79.
- Waterhouse, R.** (2008). *Printed Antennas for Wireless Communications*, John Wiley and Sons, New Jersey.
- Pozar, D. M. and Schaubert, D. H.** (1995). *Microstrip Antennas: The Analysis and Design of Microstrip Antennas and Arrays*, John Wiley and Sons, New Jersey.
- Huang, Y. and Boyle, K.** (2008). *Antennas: From Theory to Practice*, John Wiley and Sons, New Jersey.
- Bakshi, U. A. and Bakshi, A. V.** (2009). *Antenna and Wave Propagation*, Technical Publications.
- Bansal, R.** (2004). *Handbook of Engineering Electromagnetics*, CRC Press.



## Assessment of Infant Feeding Practices Among Mothers in Uranga Division, Siaya County, Kenya

By

Kipyegon, C. A.<sup>1\*</sup>

<sup>1</sup>*School of Public Health, Maseno University, Kisumu, Kenya*

*\*Corresponding Author: [andrewcheruiyot03@yahoo.com](mailto:andrewcheruiyot03@yahoo.com)*

---

### Abstract

Breastfeeding is recommended as an appropriate method of infant feeding due to the benefits both to the infant and the mother. Low prevalence of exclusive feeding has been reported in many parts of the world. The main objective of the study was to assess the infant feeding practices among mothers in Uranga Division, Siaya County, Kenya. A cross-sectional community-based study that was undertaken targeting households with children who are under five years old. The results showed that 88% had no secondary education and 10% having no formal education. Seventy five percent had their first pregnancy during teenage years. The recommended number of antenatal care (ANC) visits was attended by 55% of mothers studied. Hospital delivery was found to be at 63%. The results further showed that 53.9% of mothers practiced exclusive breastfeeding for 6months, 23% breastfed their infants for a duration of 1-2years and ordinary porridge was the most preferred complementary food. Association between place of delivery and exclusive breastfeeding was found to be significant (pearson chi square at 95% confidence interval). Results of the study have increased data on infant feeding which various stakeholders in formulating programmes and policies to promote breast feeding might utilize.

**Key words:** infant feeding, exclusive breast feeding

---

### Background

American Academy of Pediatrics (AAP) recommended breastfeeding as the appropriate method of infant feeding (Eidelman and Feldman-Winter, 2005). Breastfeeding prevalence still remains low worldwide. National survey done in the Singapore, China, India and Malaysia showed the following. 94.5% of mothers attempted breastfeeding, at 1month 71.6% were still breast feeding, 49.6% continued to

do so at 2months, and 29.8% persisted till 4months. By 6months, the breastfeeding prevalence rate fell to 21.1 % (Foo et al., 2005). A study carried out in Norway showed higher rates than in the Asian countries (Lande et al., 2003). Kiarie et al showed that mothers who planned to breastfeed were more likely to feed their infants as planned (Kiarie *et al.*, 2004). Extensive research in various countries provide evidence that breastfeeding has clear

health benefits for infants while reducing their risk for a large number of diseases such as gastrointestinal and respiratory infections (Jason *et al.*, 1984), diabetes mellitus (Owen *et al.*, 2005) and asthma (Mihirshahi *et al.*, 2007).

Research on infant feeding has been done in many parts of the world and in Africa but there exist paucity of documented facts on infant feeding in Uranga division, Siaya County.

### **Problem statement**

Poor infant feeding practices still remain a problem. Poor infant feeding include short duration of exclusive breastfeeding, mixed feeding and early cessation of breast feeding. Inappropriate complementary feeding and weaning is still a challenge among mothers. Although researches on infant feeding exist in the rest of the world, there none that has been documented in Siaya County. The main objectives of this study was to assess the infant feeding practices among mothers in Uranga Division, Siaya county and specifically determine preferred infant feeding practices among mothers in Uranga Division, Siaya County.

### **Justification**

Infant mortality still remains high especially in Kenya (KDHS, 2010). In developing world, breastfeeding is strongly correlated to a reduction in infant mortality and morbidity (Booth, 2001). This study will guide policy makers on initiating programmes that likely to promote appropriate infant feeding practices in Siaya County.

### **Methodology**

#### **Study site**

The study was carried out in Uranga Division, Siaya County, Kenya. Siaya County is one of the counties in the former Nyanza province in the Southwest part of Kenya. The total area of the county is approximately 2,456.1km<sup>2</sup>. The county lies between latitude 0<sup>o</sup> 26' to 0<sup>o</sup> 18' North and longitude 33<sup>o</sup> 58' to 34<sup>o</sup> 33' west. Uranga

division is one of the administrative divisions in Siaya County. Has population of approximately 41,564 with approximate area of 183.4km<sup>2</sup>. Siaya County has an estimated population growth rate of 0.9% per annum. Life expectancy for both males and females is 52.6 years. Infant mortality rate is approximately 102/1000 and under-five mortality at 113/1000. Total fertility rate is 4.3 children per women. Low population growth rate can be attributed to high prevalence of HIV and AIDS. Poverty level stands at 58.02%. The causes of poverty include poor soil leading to low yields, over reliance on traditional methods of agriculture, unpredictable rainfall patterns, high rate of deaths due to HIV and AIDS, and cultural believes and practices. Current data shows Doctor to patient ratio in the county is 1:96,000 and the average distance to health facilities is 6km. The most prevalent diseases are malaria, respiratory disorders and diarrhea (National Co-ordination Agency for Population and Development, 2005).

#### **Study design**

The study embraced Community-based descriptive cross-sectional study. In this case, data was collected at one point in time to get a snap shot of what was practiced at that time.

#### **Study population**

Households with children under five years were targeted for the study.

#### **Inclusion criteria**

All mothers with under five residing in Uranga Division, Rwambwa were included in the study.

#### **Exclusion criteria**

Information concerning the last born child was obtained from mothers with more than one child below five years.

#### **Sample size determination**

Sample size was calculated based on the formula previously reported by Fishers *et al.* In this formula N= 93 (total number of

households with children under five years residing in Rwambwa sub-location). Therefore the sample size of 76 households was studied.

### Sampling technique

Purposive sampling method was used to select the villages in Uranga Division; snowballing sampling method was applied to select households to be studied.

### Data collection method and tools

Pre-tested structured questionnaire was administered to mothers with under-five.

### Data analysis

Data was entered in SPSS and proportions calculated. Tables and charts were used for presentation. Chi Square was applied in establishing association between place of delivery and preferred method of infant feeding.

### Ethical consideration

Permission was obtained from Maseno University School of Public Health and Community Development, and the local administration of Uranga Division. Verbal consent was sort from all participants.

## Results

### Demographic features

Approximately 88% of mothers interviewed had not gone beyond primary school. Ten percent had no formal education.

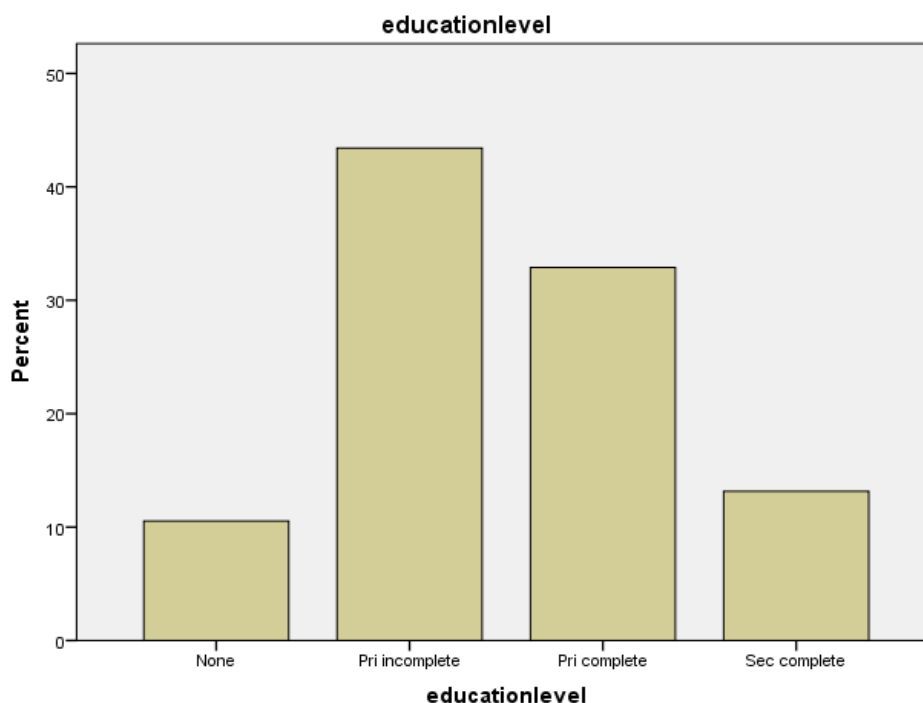


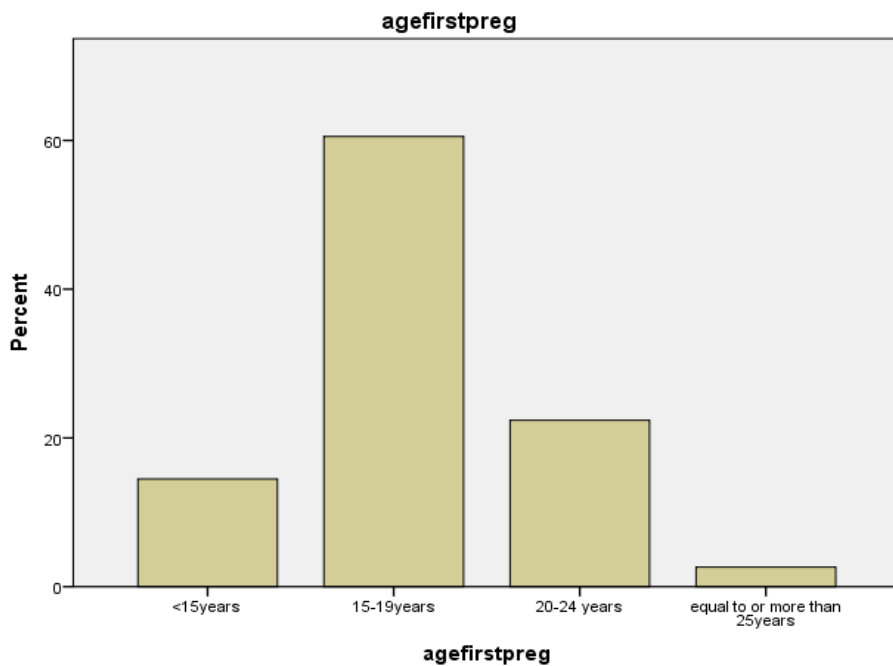
Figure 10. Education level of the respondents

Majority of mothers studied were married, few were single mothers while others were widows.

**Table 1. Marital status**

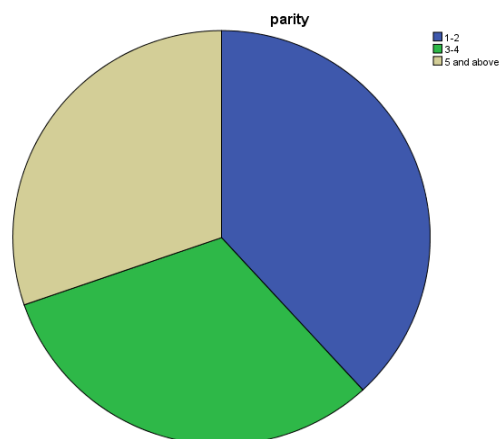
	Frequency	Percent	Valid Percent	Cumulative Percent
Valid Married	67	88.2	88.2	88.2
Valid Widowed	7	9.2	9.2	97.4
Valid Single	2	2.6	2.6	100.0
Total	76	100.0	100.0	

Early age of first pregnancy was noted with 75% having the first born during teenage years. Fifteen percent delivered become pregnant before their 15<sup>th</sup> birthday.



**Figure 11. Age at first pregnancy**

Most mothers had 1-2 children, with 30% having 5 or more children.



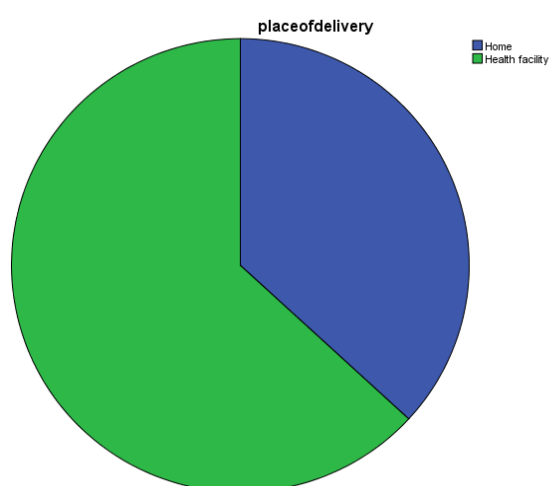
**Figure 12. Number of children per woman**

Attendance to ANC clinic was noted to be commendable, with only 7% of mothers reporting not to have attended the prenatal clinic at all. The recommended number of times, i.e. 4 or more was attended by 55% of mothers studied.

**Table 2. Number of ANC visits**

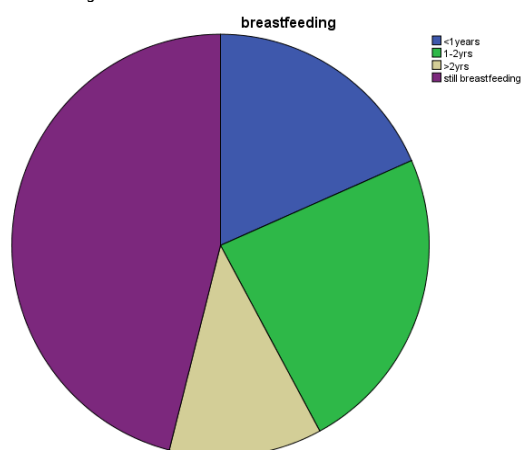
	Frequency	Percent	Valid Percent	Cumulative Percent
None	7	9.2	9.2	9.2
less 4	27	35.5	35.5	44.7
Valid 4 and above	42	55.3	55.3	100.0
Total	76	100.0	100.0	

Hospital delivery was found to be high at 63%, with the remainder delivering at home.



**Figure 13. Place of delivery**

All mothers in Uranga Division reported to have initiated breastfeeding for their infants. Although majority of the mothers were still breastfeeding, 23% reported to have breastfed their children for duration between 1 and 2 years while 18% breastfed their children for duration less than 1 year.



**Figure 14. Duration of breastfeeding**

Contrary to previous researches, 53% reported to have exclusively breastfed their babies for 6 months. The results are as shown in the table. It was also found out that place of delivery has effect on exclusive breastfeeding.

**Table 3. Duration of exclusive breastfeeding**

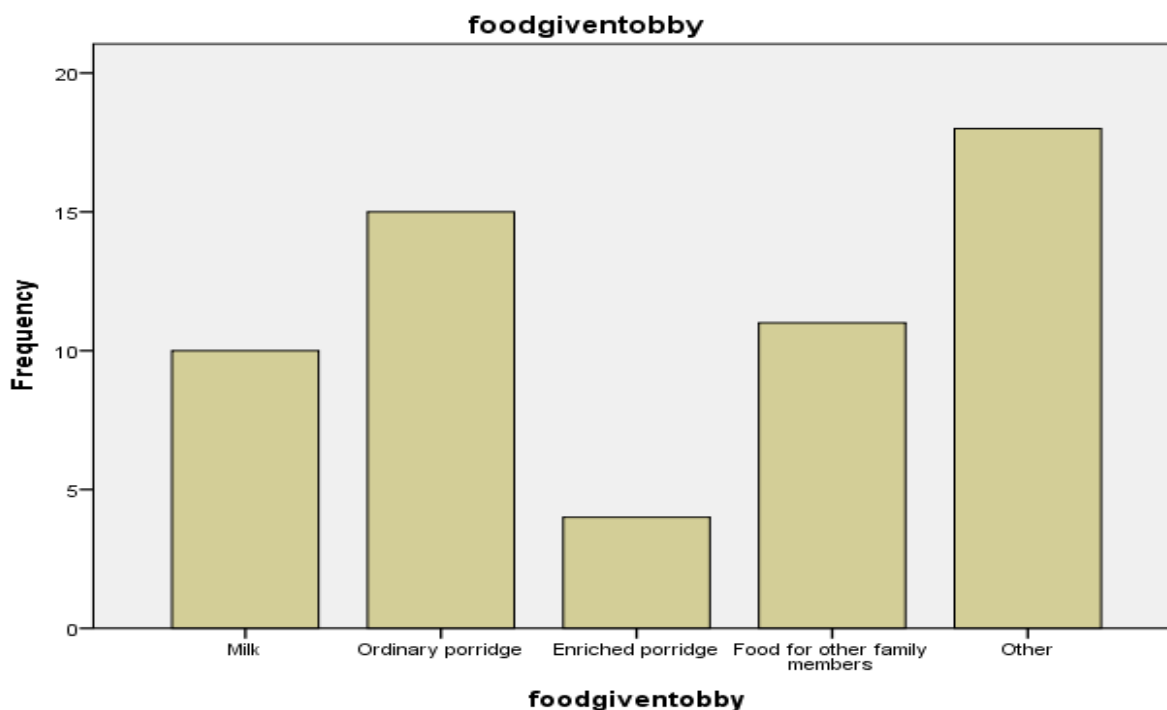
		Frequency	Percent	Valid Percent	Cumulative Percent
Valid	Less than 6months	30	39.5	39.5	39.5
	6months and above	41	53.9	53.9	93.4
	N/A	5	6.6	6.6	100.0
	Total	76	100.0	100.0	

Association between place of delivery and exclusive breastfeeding was found to be significant.

**Table 4. Place of delivery against exclusive breastfeeding**

		Exclusive breastfeeding			Total
		Less than 6months	6months above	and N/A	
Place of delivery	Home	12	8	2	22
	Health facility	12	21	3	36
Total		24	29	5	58

Ordinary porridge was the most preferred complementary feed among mothers in Uranga Division. Milk was given children by 17% of the mothers, will 14% of the children eat food for the rest of the family. Enriched porridge was given by 9% of the mothers. The results are shown in the bar graph below.



**Figure 15. Complementary food given to infants**

### Discussion

Mothers in Uranga Division were found to breastfeed their children for a shorter duration than the recommended 2 years (40%). Previous researches showed low prevalence of exclusive breastfeeding in the world, findings from Uranga Division portray a different picture with higher prevalence of 53.9%. The National survey done in Kenya showed a prevalence of exclusive breastfeeding at 32% (KDHS, 2010). Place of delivery has an impact on exclusive breastfeeding whereby mothers who deliver in a health facility were more likely to exclusively breastfeed for 6 months. This finding might be due to nutrition counseling given to mothers in health facilities. Ordinary porridge was the preferred complementary feed due to availability and less costly. Other complementary feeds include Cerelac, and avocados. These findings are in line with high poverty level in the area with majority earning less than Kshs. 2000.

### Conclusion and Recommendation

The reason for high prevalence of exclusive breastfeeding in Uranga needs further exploration so that it can be applied in other parts of the country and the world. There is need to further sensitize mothers on the importance of exclusive breastfeeding, and more importantly on longer duration of breastfeeding. Raising the level of income for household income might improve on appropriate complementary feeds. Mothers should be encouraged to deliver in health facilities because it improves length of exclusive breastfeeding.

### Acknowledgement

I would like to thank Maseno University School of Public health for giving me an opportunity to do this study. I would also like to give appreciation to the late Dr. Carren A. Watsierah for her encouragement and guidance throughout the study period. I wish to extend further gratitude to Evelyn M. Nyambane for her support during dissemination of this study. Lastly, I thank Deborah M. Ongaro for helping me during manuscript preparation.

## References

- Booth, I.** (2001) Does the duration of breast feeding matter? Maybe but not enough to counter current support for breast feeding. *BMJ: British Medical Journal* 322, 625.
- Eidelman, A. and Feldman-Winter, L.** (2005) From the American Academy of Pediatrics: Policy Statement: Breastfeeding and the Use of Human Milk. *Pediatrics* 115, 496-506.
- Foo, L. L., Quek, S. J. S., Ng, S. A., Lim, M. T. and Deurenberg-Yap, M.** (2005) Breastfeeding prevalence and practices among Singaporean Chinese, Malay and Indian mothers. *Health Promotion International* 20, 229-237.
- Jason, J. M., Nieburg, P. and Marks, J. S.** (1984) Mortality and Infectious Disease Associated with Infant-Feeding Practices in Developing Countries. *Pediatrics* 74, 702-727.
- KDHS** (2010) Kenya Demographic and Health Survey 2008-09. Kenya Central Bureau of Statistics ICF, Macro. Calverton, Maryland. Central Bureau of Statistics.
- Kiarie, J.N., Richardson, B. A., Mbori-Ngacha, D., Nduati, R. W. and John-Stewart, G. C.** (2004) Infant feeding practices of women in a perinatal HIV-1 prevention study in Nairobi, Kenya. *Journal of acquired immune deficiency syndromes* (1999) 35, 75.
- Lande, B., Andersen, L. F., Bærug, A., Trygg, K. U., Lund-Larsen, K., Veierød, M. B. and Bjørneboe, G. E. A.** (2003) Infant feeding practices and associated factors in the first six months of life: The Norwegian Infant Nutrition Survey. *Acta Pædiatrica* 92, 152-161.
- Mihrshahi, S., Ampon, R., Webb, K., Almqvist, C., Kemp, A. S., Hector, D., Marks, G. B. and for the, C. T.** (2007) The association between infant feeding practices and subsequent atopy among children with a family history of asthma. *Clinical & Experimental Allergy* 37, 671-679.
- National Co-ordination Agency for Population and Development, M.o.P.a.N.D.** (2005) Siaya District Strategic plan 2005-2010 for implementation of the National population policy for sustainable development.
- Owen, C. G., Martin, R. M., Whincup, P. H., Smith, G. D. and Cook, D. G.** (2005) Effect of Infant Feeding on the Risk of Obesity Across the Life Course: A Quantitative Review of Published Evidence. *Pediatrics* 115, 1367-1377.



# On a Complex Spacetime Frame: New Foundation for Physics and Mathematics

By

Joseph Akeyo Omolo<sup>1\*</sup>

*1; Department of Physics and Materials Science, Maseno University, Private Bag, Maseno, Kenya*

*\*Corresponding author E-mail: [ojakeyo04@yahoo.co.uk](mailto:ojakeyo04@yahoo.co.uk)*

---

## Abstract

This paper provides a derivation of a unit vector specifying the temporal axis of four-dimensional space-time frame as an imaginary axis in the direction of light or general wave propagation. The basic elements of the resulting complex four-dimensional spacetime frame are complex four-vectors expressed in standard form as four-component quantities specified by four unit vectors, three along space axes and one along the imaginary temporal axis. Consistent mathematical operations with the complex four-vectors have been developed in Euclidean form, which provide extensions of standard vector analysis identities to complex four-dimensional spacetime. The general orientation of the temporal unit vector relative to all the three mutually perpendicular spatial unit vectors leads to appropriate modifications of fundamental results describing the invariant length of the spacetime event interval, time dilation, mass increase with speed and relativistic energy conservation law. Contravariant and covariant forms have been defined, providing appropriate definition of the invariant length of a complex four-vector and appropriate definitions of complex tensors within the complex four-dimensional spacetime frame, thus setting a new geometrical framework for physics and mathematics.

**Key words:** spacetime, physics, mathematics, unit vector, operations

---

## Introduction

Four-dimensional space-time frame is the natural reference frame for describing the general dynamics of physical systems. Its basic elements are four-vectors, which are suitable for expressing field equations and associated physical quantities in consistent forms. An interesting point to note is that, while physicists and mathematicians are quite comfortable using four-vectors to develop field theories and generalizations of geometry, no attempt has ever been made to identify a unit vector to specify the temporal direction in a manner equivalent to the

specification of the three space axes by corresponding unit vectors  $\hat{x}, \hat{y}, \hat{z}$ . The current representation of four-vectors in contravariant and covariant forms is obviously *incomplete*, since a unit vector specifying the temporal axis has not been defined.

The definition and specification of a reference frame for theoretical description and experimental verification of various features of the dynamics of a physical system should be complete and the relative orientations of its coordinate axes should be

as general as possible. In general, each *coordinate axis* is a vector specified by a *unit vector* giving its direction and a *coordinate* giving its magnitude. In the current definition of the dynamical spacetime reference frame, only the three spatial axes, namely *x*-axis, *y*-axis and *z*-axis, have been fully defined by specifying their corresponding unit vectors and coordinates. The temporal axis has not been fully defined since a corresponding unit vector giving its direction has not been identified. The current definition of the dynamical spacetime frame is therefore incomplete. It is important to note that *the general orientation of the temporal axis relative to the three spatial axes cannot be fixed without specifying the temporal unit vector*, contrary to the present assumption implicit in conventional four-vector mathematics that the temporal axis is perpendicular to all the three mutually perpendicular spatial axes. We observe that there is no physically

justifiable reason why a dynamical reference frame such as the four-dimensional spacetime frame must be composed of mutually perpendicular coordinate axes. We therefore propose that the relative orientations of all the four spacetime coordinate axes should be general enough to accommodate as much information as possible about the dynamics of a physical system.

The purpose of this paper is to derive and specify the temporal unit vector to complete and generalize the specification of the dynamical four-dimensional spacetime frame. The derivation is presented in the next section and the appropriate definition of four-vectors, together with suitable mathematical operations and physical consequences are developed in the subsequent sections.

### The temporal unit vector

The starting point is the realization that dynamics in a general four-dimensional spacetime frame is governed by wave equations, which we express in the form

$$\left(-\frac{1}{c^2} \frac{\partial^2}{\partial t^2} + \vec{\nabla}^2\right)\psi = -f(\vec{r}, t) \quad (1)$$

where  $\psi(\vec{r}, t)$  is an arbitrary function which may represent a temporal or spatial component of a four-vector, while  $f(\vec{r}, t)$  is a function representing external sources.

In the standard Cartesian coordinate system, the spatial component of the derivative operator  $\vec{\nabla}$  is a three-component vector defined as

$$\vec{\nabla} = \frac{\partial}{\partial x} \hat{x} + \frac{\partial}{\partial y} \hat{y} + \frac{\partial}{\partial z} \hat{z} \quad (2a)$$

where  $\hat{x}, \hat{y}, \hat{z}$  are the mutually perpendicular unit vectors along the three space directions.

The Laplacian  $\vec{\nabla}^2$  is then obtained as a vector dot product

$$\vec{\nabla}^2 = \vec{\nabla} \cdot \vec{\nabla} = \frac{\partial}{\partial x} \hat{x} \cdot \frac{\partial}{\partial x} \hat{x} + \frac{\partial}{\partial y} \hat{y} \cdot \frac{\partial}{\partial y} \hat{y} + \frac{\partial}{\partial z} \hat{z} \cdot \frac{\partial}{\partial z} \hat{z} \quad (2b)$$

The second order partial differential operator on the l.h.s. of of the wave equation (1) is then expressed in the form

$$-\frac{1}{c^2} \frac{\partial^2}{\partial t^2} + \vec{\nabla} \cdot \vec{\nabla} = -\frac{1}{c^2} \frac{\partial^2}{\partial t^2} + \frac{\partial}{\partial x} \hat{x} \cdot \frac{\partial}{\partial x} \hat{x} + \frac{\partial}{\partial y} \hat{y} \cdot \frac{\partial}{\partial y} \hat{y} + \frac{\partial}{\partial z} \hat{z} \cdot \frac{\partial}{\partial z} \hat{z} \quad (2c)$$

The form in equation (2c) makes it evidently clear that some information is missing, since the spatial component  $\vec{\nabla}^2$  can be expressed in vector dot product form with the vector  $\vec{\nabla}$

defined in equation (2a), while the temporal component  $-\frac{1}{c^2} \frac{\partial^2}{\partial t^2}$  cannot be expressed in a

similar vector dot product form without defining and specifying a unit vector along the temporal direction.

I observe that the missing information is hidden in the speed of light occurring in the temporal component in the form  $\frac{1}{c^2}$  (or for any general wave with phase velocity, the

information is hidden in the speed occurring in the temporal component in the form  $\frac{1}{v^2}$  ).

This follows from the fact that the speed  $c$ , wave number  $k$  and angular frequency  $\omega$  of light are related in the form

$$c = \frac{\omega}{k} \Rightarrow \frac{1}{c^2} = \frac{k^2}{\omega^2} \quad (3a)$$

Note that for a general wave characterized by a phase velocity  $\bar{v}$ , the same relation applies, i.e.,  $v = \frac{\omega}{k}$ , and we can replace  $c$  with  $v$  everywhere.

I introduce the wave vector  $\vec{k}$  to obtain the dot product form

$$k^2 = \vec{k} \cdot \vec{k} \Rightarrow \frac{1}{c^2} = \frac{\vec{k}}{\omega} \cdot \frac{\vec{k}}{\omega} \quad (3b)$$

Expressing the wave vector  $\vec{k}$  in terms of its unit vector  $\hat{k}$  and wave number  $k$  through the standard definition

$$\vec{k} = k\hat{k} \quad (3c)$$

I write equation (3b) in the useful form

$$\frac{1}{c^2} = \frac{k}{\omega} \hat{k} \cdot \frac{k}{\omega} \hat{k} \quad (3d)$$

Substituting  $\frac{1}{c^2}$  from equation (3d) into the temporal component, introducing the imaginary

number  $i = \sqrt{-1}$  and reintroducing the speed  $c$  by substituting  $\frac{1}{c} = \frac{k}{\omega}$  from equation (3a),

we express the temporal component in the desired one-dimensional dot product form

$$-\frac{1}{c^2} \frac{\partial^2}{\partial t^2} = \frac{i}{c} \frac{\partial}{\partial t} \hat{k} \cdot \frac{i}{c} \frac{\partial}{\partial t} \hat{k} \quad (4)$$

which is now consistent with the dot product forms of the spatial components in equation (2d).

This is the main result in this paper. I have succeeded in deriving and identifying the *unit wave vector*  $\hat{k}$  as the unit vector specifying the temporal direction in four-dimensional spacetime frame. The occurrence of the imaginary number  $i = \sqrt{-1}$  leads to the interpretation that the temporal axis is an *imaginary axis* specified by the unit wave vector  $\hat{k}$  defining the direction of light / wave propagation within a four-dimensional *complex* spacetime frame.

### ***The derivative four-vector***

Substituting equation (4) into equation (2c) now provides the complete dot product form obtained as

$$-\frac{1}{c^2} \frac{\partial^2}{\partial t^2} + \vec{\nabla} \cdot \vec{\nabla} = \frac{i}{c} \frac{\partial}{\partial t} \hat{k} \cdot \frac{i}{c} \frac{\partial}{\partial t} \hat{k} + \frac{\partial}{\partial x} \hat{x} \cdot \frac{\partial}{\partial x} \hat{x} + \frac{\partial}{\partial y} \hat{y} \cdot \frac{\partial}{\partial y} \hat{y} + \frac{\partial}{\partial z} \hat{z} \cdot \frac{\partial}{\partial z} \hat{z} \quad (5a)$$

The r.h.s. of equation (5a) can be expressed in a general four-component vector dot product form to obtain

$$-\frac{1}{c^2} \frac{\partial^2}{\partial t^2} + \vec{\nabla} \cdot \vec{\nabla} = \left( \frac{i}{c} \frac{\partial}{\partial t} \hat{k} + \vec{\nabla} \right) \cdot \left( \frac{i}{c} \frac{\partial}{\partial t} \hat{k} + \vec{\nabla} \right) + d \quad (5b)$$

where  $d$  is a derivative operator composed of extra terms which arise if the temporal unit vector,  $\hat{k}$ , has general orientation not perpendicular to the spatial unit vectors,  $\hat{x}, \hat{y}, \hat{z}$ , thus satisfying

$$\hat{k} \cdot \hat{x} \neq 0 ; \hat{k} \cdot \hat{y} \neq 0 ; \hat{k} \cdot \hat{z} \neq 0 \Rightarrow d \neq 0 \quad (5c)$$

The derivative operator  $d$  vanishes in the special case where the temporal unit vector is perpendicular to all the three spatial unit vectors, thus satisfying

$$\hat{k} \cdot \hat{x} = 0 ; \hat{k} \cdot \hat{y} = 0 ; \hat{k} \cdot \hat{z} = 0 \Rightarrow d = 0 \quad (5d)$$

It is then clear that the first term on the r.h.s. of equation (5b) is the dot product of a four-component derivative vector, which we shall call the *spacetime derivative four-vector* denoted by  $\nabla$  taking the form

$$\nabla = \frac{i}{c} \frac{\partial}{\partial t} \hat{k} + \vec{\nabla} = \frac{i}{c} \frac{\partial}{\partial t} \hat{k} + \frac{\partial}{\partial x} \hat{x} + \frac{\partial}{\partial y} \hat{y} + \frac{\partial}{\partial z} \hat{z} \quad (6a)$$

Moving the imaginary number  $i = \sqrt{-1}$  down to the denominator to rewrite the temporal component of the spacetime derivative four-vector in the form

$$i \frac{\partial}{\partial t} = \frac{\partial}{\partial(-ict)} = \frac{\partial}{\partial x_k} \quad (6b)$$

we identify the imaginary temporal coordinate  $x_k$  defined along the temporal axis by

$$x_k = -ict \quad (6c)$$

The temporal coordinate  $x_k = -ict$  is seen to be defined in terms of an imaginary time  $it$ .

We have thus rediscovered the concept of imaginary time, first introduced independently by Poincare [1] and Lorentz [2] in their original theories of electrodynamics in a four-dimensional spacetime frame. The rediscovery of an imaginary time in the present paper thus takes us back to the very original ideas of a space time frame, but now completely specified through a derivation and clear identification of the temporal unit vector.

We use equation (6a) to obtain

$$\nabla \cdot \nabla = \left( \frac{i}{c} \frac{\partial}{\partial t} \hat{k} + \vec{\nabla} \right) \cdot \left( \frac{i}{c} \frac{\partial}{\partial t} \hat{k} + \vec{\nabla} \right) \quad (6d)$$

which we substitute into equation (5b) to obtain

$$\nabla \cdot \nabla = -\left( \frac{1}{c^2} \frac{\partial^2}{\partial t^2} - \vec{\nabla}^2 + d \right) \quad (6e)$$

Full expansion of  $\nabla \cdot \nabla$  as defined in equation (6d), considering general orientation of  $\hat{k}$  specified by equation (5c), provides the general form of  $d$  to be used in equation (6c),

revealing a modification of the standard d'Alembertian operator  $\frac{1}{c^2} \frac{\partial^2}{\partial t^2} - \vec{\nabla}^2$  which is a wave propagation operator in classical and quantum field theories. The usual form of the d'Alembertian operator is obtained in the conventional four-vector mathematics based on the assumption that the temporal and spatial axes in a spacetime frame are all mutually perpendicular.

## Vectors in four-dimensional complex spacetime

Having defined the complex spacetime derivative four-vector  $\nabla$  in equation (6a), we proceed to the general definition of the other physical or mathematical four-vectors in similar form and then developing the appropriate mathematical operations with four-vectors in the four-dimensional complex spacetime.

To motivate the definition of a general complex four-vector, we consider two fundamental equations in electrodynamics, namely the continuity equation for electric charge conservation and the Lorentz gauge condition in the form

$$\frac{\partial \rho}{\partial t} + \vec{\nabla} \cdot \vec{J} = 0 \quad ; \quad \frac{\partial \phi}{\partial t} + \vec{\nabla} \cdot \vec{A} = 0 \quad (7a)$$

where  $\rho$  is the electric charge density,  $\vec{J}$  is the electric current density,  $\phi$  is the electromagnetic field scalar potential and  $\vec{A}$  is the electromagnetic field vector potential.

Introducing  $\frac{i}{c} \frac{c}{i} = 1$  and the temporal unit vector  $\hat{k}$  according to  $\hat{k} \cdot \hat{k} = 1$ , we express equation (7a) in the complete dot product form

$$\left(\frac{i}{c} \frac{\partial}{\partial t} \hat{k}\right) \cdot \left(\frac{c}{i} \rho \hat{k}\right) + \vec{\nabla} \cdot \vec{J} = 0 \quad ; \quad \left(\frac{i}{c} \frac{\partial}{\partial t} \hat{k}\right) \cdot \left(\frac{c}{i} \phi \hat{k}\right) + \vec{\nabla} \cdot \vec{A} = 0 \quad (7b)$$

which we recognize as four-component divergence equations expressible in the general four-vector divergence form

$$\left(\frac{i}{c} \frac{\partial}{\partial t} \hat{k} + \vec{\nabla}\right) \cdot \left(\frac{c}{i} \rho \hat{k} + \vec{J}\right) = 0 \quad ; \quad \left(\frac{i}{c} \frac{\partial}{\partial t} \hat{k} + \vec{\nabla}\right) \cdot \left(\frac{c}{i} \phi \hat{k} + \vec{A}\right) = 0 \quad ; \quad \hat{k} \cdot \vec{J} = 0 \quad ; \quad \hat{k} \cdot \vec{A} = 0 \quad (7c)$$

in the case where the temporal unit vector is perpendicular to the spatial unit vectors such that  $\hat{k} \cdot \vec{J} = 0, \hat{k} \cdot \vec{A} = 0$ .

In equation (7c), we identify the complex spacetime derivative four-vector  $\nabla$  defined earlier in equation (6a), the electric current density four-vector  $J$  and the electromagnetic field potential four-vector  $A$  defined within the four-dimensional complex spacetime frame in the form

$$J = \frac{c}{i} \rho \hat{k} + \vec{J} = -ic \rho \hat{k} + \vec{J} \quad ; \quad A = \frac{c}{i} \phi \hat{k} + \vec{A} = -ic \phi \hat{k} + \vec{A} \quad (7d)$$

Throughout this work, we use conventional notation, denoting four-vectors by uppercase symbols such as  $J, A$  and the usual three-component vectors in three-dimensional Euclidean space by symbols with arrow signs over them such as  $\vec{r}, \vec{\nabla}, \vec{J}, \vec{A}$ .

We now proceed to define a general complex four-vector  $V$  in the form

$$V = V_k \hat{k} + \vec{V} = -ic \Lambda \hat{k} + V_x \hat{x} + V_y \hat{y} + V_z \hat{z} \quad (8a)$$

with the imaginary temporal component  $V_k$  and the spatial vector component  $\vec{V}$  defined by

$$V_k = -ic \Lambda \quad ; \quad \vec{V} = V_x \hat{x} + V_y \hat{y} + V_z \hat{z} \quad (8b)$$

where  $\Lambda$  is a scalar quantity specifying the nature of the temporal component of the four-vector. All the vector components and therefore the four-vectors are general functions of the position vector  $\vec{r} = x\hat{x} + y\hat{y} + z\hat{z}$  and the time  $t$ , i.e.,  $\Lambda = \Lambda(\vec{r}, t), \vec{V} = \vec{V}(\vec{r}, t), V = V(\vec{r}, t)$ .

In general, the temporal component of each four-vector occurs along the imaginary temporal axis,  $i\hat{k}$ , multiplied by a factor  $-c$ , where  $c$  is the speed of light. We observe that if we base the derivation on a general wave equation characterized by a phase velocity  $\vec{v}$ , then  $c$

would be replaced everywhere by the speed  $v = |\vec{v}|$  of the general wave. The speed  $v = c$  then becomes specific to light or electromagnetic wave.

### Mathematical operations with complex four-vectors

The general four-component vector form in equation (8a) with all unit vectors specified now allows us to carry out four-vector mathematical operations in the complex spacetime frame in the familiar Euclidean form, exactly the same as the standard mathematical operations with the three-component vectors in three-dimensional Euclidean space.

In developing the mathematical operations in general form, we shall take the temporal unit vector  $\hat{k}$  to be of general orientation relative to the spatial unit vectors  $\hat{x}, \hat{y}, \hat{z}$ , satisfying the conditions in equation (5c). We use two general four-vectors  $V$  and  $U$  defined by

$$V = V_k \hat{k} + \vec{V} \quad , \quad V_k = -ic\Lambda \quad ; \quad U = U_k \hat{k} + \vec{U} = -ic\phi \hat{k} + \vec{U} \quad , \quad U_k = -ic\phi \quad (9)$$

to develop the mathematical operations with four-vectors in complex spacetime frame. The basic mathematical operations are essentially addition, subtraction, dot product, cross product, divergence and curl, which we carry out here in Euclidean form.

#### Addition and subtraction

Four-vector addition and subtraction is straightforward, taking the form

$$W = U \pm V = (U_k \pm V_k) \hat{k} + (\vec{U} \pm \vec{V}) \quad (10)$$

#### The dot product

The dot product of the four-vectors  $U$  and  $V$  is obtained as

$$U \cdot V = (U_k \hat{k} + \vec{U}) \cdot (V_k \hat{k} + \vec{V}) \quad (11a)$$

which we expand term by term, maintaining the order of components in the products to obtain

$$U \cdot V = U_k V_k + \vec{U} \cdot \vec{V} + \hat{k} \cdot (U_k \vec{V} + \vec{U} V_k) \quad (11b)$$

Substituting  $U_k = -ic\phi, V_k = -ic\Lambda$  from equation (9) into equation (11b), we express the dot product in the final form

$$U \cdot V = \vec{U} \cdot \vec{V} - c^2 \phi \Lambda - ic \hat{k} \cdot (\phi \vec{V} + \vec{U} \Lambda) \quad (11c)$$

The four-vector dot product obtained in equations (11b)-(11c) takes the general form, with the temporal unit vector  $\hat{k}$  having general orientation relative to the spatial unit vectors  $\hat{x}, \hat{y}, \hat{z}$ , here satisfying the conditions

$$\hat{k} \cdot \hat{x} \neq 0 \quad , \quad \hat{k} \cdot \hat{y} \neq 0 \quad , \quad \hat{k} \cdot \hat{z} \neq 0 \quad \Rightarrow \quad \hat{k} \cdot \vec{U} \neq 0 \quad ; \quad \hat{k} \cdot \vec{V} \neq 0 \quad (11d)$$

The dot product can be made even more general by taking the three spatial unit vectors  $\hat{x}, \hat{y}, \hat{z}$  also to have general orientation relative to each other.

The special case where all the four spacetime unit vectors are mutually perpendicular satisfying equation (5d) gives the usual result for four-vector dot product according to

$$\hat{k} \cdot \vec{U} = 0 \quad , \quad \hat{k} \cdot \vec{V} = 0 \quad ; \quad U \cdot V = \vec{U} \cdot \vec{V} - c^2 \phi \Lambda \quad (11e)$$

generally obtained through the conventional four-vector mathematics in standard textbooks in classical electrodynamics and relativistic physics. A comparison of the general result in

equation (11c), which has an imaginary part under the condition (11d) and the result in equation (11e) under the special conditions given in equations (5d) and (11e), reveals that conventional four-vector mathematics is inadequate in scope and content. The physical consequences of the inadequacy of conventional four-vector mathematics commonly used in electrodynamics and relativistic physics will follow from equation (11c) expressed in the form

$$U \cdot V = -(1 + i \frac{c\hat{k} \cdot (\varphi\vec{V} + \vec{U}\Lambda)}{c^2\varphi\Lambda - \vec{U} \cdot \vec{V}})(c^2\varphi\Lambda - \vec{U} \cdot \vec{V}) \quad (11f)$$

with an *invariant length*  $\overline{UV}$  obtained in the general form

$$\overline{UV} = |-U \cdot V| = \sqrt{1 + \frac{(c\hat{k} \cdot (\varphi\vec{V} + \vec{U}\Lambda))^2}{(c^2\varphi\Lambda - \vec{U} \cdot \vec{V})^2}}(c^2\varphi\Lambda - \vec{U} \cdot \vec{V}) \quad (11g)$$

where we immediately notice a modification factor depending on the general orientation of the temporal unit vector  $\hat{k}$  relative to the spatial unit vectors  $\hat{x}, \hat{y}, \hat{z}$ , such that  $\hat{k} \cdot \vec{U} \neq 0, \hat{k} \cdot \vec{V} \neq 0$ . The fundamental physical consequences based on the general form of the invariant length in equation (11g) will be obtained in section-5 below.

### ***The cross product***

The cross product of the four-vectors  $U$  and  $V$  is obtained as

$$U \times V = (U_k \hat{k} + \vec{U}) \times (V_k \hat{k} + \vec{V}) \quad (12a)$$

which we expand term by term to obtain

$$U \times V = U_k V_k \hat{k} \times \hat{k} + \vec{U} \times \vec{V} + U_k \hat{k} \times \vec{V} + \vec{U} \times V_k \hat{k} \quad (12b)$$

Using  $\hat{k} \times \hat{k} = 0, \vec{U} \times \hat{k} = -\hat{k} \times \vec{U}$  gives

$$U \times V = \vec{U} \times \vec{V} + \hat{k} \times (U_k \vec{V} - \vec{U} V_k) \quad (12c)$$

Substituting  $U_k = -ic\varphi, V_k = -ic\Lambda$  into equation (12c), we obtain the four-vector cross product in the final form

$$U \times V = \vec{U} \times \vec{V} - ic\hat{k} \times (\varphi\vec{V} - \vec{U}\Lambda) \quad (12d)$$

### ***Divergence of a four-vector***

Setting  $U$  equal to the spacetime derivative four-vector  $\nabla$  according to

$$U = \nabla = \frac{i}{c} \frac{\partial}{\partial t} \hat{k} + \vec{\nabla} = -ic(-\frac{1}{c^2} \frac{\partial}{\partial t}) \hat{k} + \vec{\nabla} = -ic\varphi\hat{k} + \vec{U} \quad (13a)$$

with

$$\varphi = -\frac{1}{c^2} \frac{\partial}{\partial t} ; \vec{U} = \vec{\nabla} \quad (13b)$$

in the general four-vector dot product obtained in equation (12d), we obtain the divergence of a general four-vector  $V$  in the final form

$$\nabla \cdot V = \frac{\partial \Lambda}{\partial t} + \vec{\nabla} \cdot \vec{V} + i\hat{k} \cdot (\frac{1}{c} \frac{\partial \vec{V}}{\partial t} - \vec{\nabla}(c\Lambda)) \quad (13c)$$

### ***Curl of a four-vector***

Setting  $U$  equal to the spacetime derivative four-vector  $\nabla$  according to equations (13a)-(13b) in the general four-vector cross product obtained in equation (12d), we obtain the curl of a general four-vector  $V$  in the final form

$$\nabla \times V = \vec{\nabla} \times \vec{V} - i\left(\frac{1}{c} \frac{\partial \vec{V}}{\partial t} + \vec{\nabla}(c\Lambda)\right) \times \hat{k} \quad (14)$$

#### **Four-vector identities**

We now derive some basic four-vector identities in complex four-dimensional spacetime frame, which generalize standard vector identities in three-dimensional Euclidean space.

##### **a) Curl of gradient four-vector**

A gradient four-vector  $\nabla\Phi$  generated through application of the spacetime derivative four-vector  $\nabla$  on a scalar function  $\Phi$  is obtained as

$$\nabla\Phi = \left(\frac{i}{c} \frac{\partial}{\partial t} \hat{k} + \vec{\nabla}\right)\Phi = -ic\left(-\frac{1}{c^2} \frac{\partial\Phi}{\partial t}\right)\hat{k} + \vec{\nabla}\Phi \quad (15a)$$

Setting the general four-vector  $V$  equal to the gradient four-vector according to

$$V = \nabla\Phi = -ic\left(-\frac{1}{c^2} \frac{\partial\Phi}{\partial t}\right)\hat{k} + \vec{\nabla}\Phi = -ic\Lambda\hat{k} + \vec{V} \quad (15b)$$

with

$$\Lambda = -\frac{1}{c^2} \frac{\partial\Phi}{\partial t} ; \vec{V} = \vec{\nabla}\Phi \quad (15c)$$

in the general curl of a four-vector obtained in equation (14), we obtain the curl of a gradient four-vector  $\nabla\Phi$  in the form

$$\nabla \times \nabla\Phi = \vec{\nabla} \times \vec{\nabla}\Phi - i\left(\frac{1}{c} \frac{\partial \vec{\nabla}\Phi}{\partial t} - \vec{\nabla}\left(\frac{1}{c} \frac{\partial\Phi}{\partial t}\right)\right) \times \hat{k} \quad (15d)$$

which on using the standard three-dimensional space vector analysis results

$$\vec{\nabla} \times \vec{\nabla}\Phi = 0 ; \frac{1}{c} \frac{\partial \vec{\nabla}\Phi}{\partial t} = \vec{\nabla}\left(\frac{1}{c} \frac{\partial\Phi}{\partial t}\right) \quad (15e)$$

gives the final result

$$\nabla \times \nabla\Phi = 0 \quad (16)$$

This shows that the curl of a gradient four-vector vanishes. This four-vector identity generalizes the corresponding vector identity in standard three-dimensional Euclidean space given in the first part of equation (15e).

##### **b) Divergence of curl of a four-vector**

Taking the divergence of the curl of the general four-vector  $V$  in equation (14), we obtain

$$\nabla \cdot \nabla \times V = \left(\frac{i}{c} \frac{\partial}{\partial t} \hat{k} + \vec{\nabla}\right) \cdot \left(\vec{\nabla} \times \vec{V} - i\left(\frac{1}{c} \frac{\partial \vec{V}}{\partial t} + \vec{\nabla}(c\Lambda)\right) \times \hat{k}\right) \quad (17a)$$

which on expanding term by term becomes

$$\nabla \cdot \nabla \times V = \frac{i}{c} \frac{\partial}{\partial t} \hat{k} \cdot \vec{\nabla} \times \vec{V} + \frac{1}{c} \frac{\partial}{\partial t} \hat{k} \cdot \left(\frac{1}{c} \frac{\partial \vec{V}}{\partial t} + \vec{\nabla}(c\Lambda)\right) \times \hat{k} + \vec{\nabla} \cdot \vec{\nabla} \times \vec{V} - i\vec{\nabla} \cdot \left(\frac{1}{c} \frac{\partial \vec{V}}{\partial t} + \vec{\nabla}(c\Lambda)\right) \times \hat{k} \quad (17b)$$

Applying standard three-dimensional space vector analysis results

$$\vec{\nabla} \cdot \vec{\nabla} \times \vec{V} = 0 ; \hat{k} \cdot \left(\frac{1}{c} \frac{\partial \vec{V}}{\partial t} + \vec{\nabla}(c\Lambda)\right) \times \hat{k} = 0 \quad (17c)$$

we express equation (13b) in the form

$$\nabla \cdot \nabla \times V = i\left\{\hat{k} \cdot \vec{\nabla} \times \frac{1}{c} \frac{\partial \vec{V}}{\partial t} - \vec{\nabla} \cdot \left(\frac{1}{c} \frac{\partial \vec{V}}{\partial t} + \vec{\nabla}(c\Lambda)\right) \times \hat{k}\right\} \quad (17d)$$

Application of standard three-dimensional space vector identity



$$\vec{\nabla} \cdot (\vec{Q} \times \vec{R}) = \vec{R} \cdot (\vec{\nabla} \times \vec{Q}) - \vec{Q} \cdot (\vec{\nabla} \times \vec{R}) \quad (17e)$$

gives

$$\vec{\nabla} \cdot \left( \frac{1}{c} \frac{\partial \vec{V}}{\partial t} + \vec{\nabla}(c\Lambda) \right) \times \hat{k} = \hat{k} \cdot \vec{\nabla} \times \left( \frac{1}{c} \frac{\partial \vec{V}}{\partial t} + \vec{\nabla}(c\Lambda) \right) - \left( \frac{1}{c} \frac{\partial \vec{V}}{\partial t} + \vec{\nabla}(c\Lambda) \right) \cdot \vec{\nabla} \times \hat{k} \quad (17f)$$

which on using

$$\vec{\nabla} \times \vec{\nabla}(c\Lambda) = 0 \quad ; \quad \vec{\nabla} \times \hat{k} = 0 \quad (17g)$$

takes the final form

$$\vec{\nabla} \cdot \left( \frac{1}{c} \frac{\partial \vec{V}}{\partial t} + \vec{\nabla}(c\Lambda) \right) \times \hat{k} = \hat{k} \cdot \vec{\nabla} \times \frac{1}{c} \frac{\partial \vec{V}}{\partial t} \quad (17h)$$

Substituting equation (17h) into equation (17d) gives the final result

$$\nabla \cdot \nabla \times V = 0 \quad (18)$$

This shows that the divergence of curl of a four-vector vanishes. This four-vector identity generalizes the corresponding vector identity in standard three-dimensional space given in the first part of equation (17c).

### c) *General vanishing four-vector dot product: $U \cdot (U \times V)$*

The important identity on the vanishing of the divergence of curl of a four-vector in equation (18) can be generalized by taking the dot product of the four-vector  $U$  and the cross product of the four-vectors  $U$  and  $V$  which on using the general result in equation (12c) is obtained as

$$U \cdot (U \times V) = (U_k \hat{k} + \vec{U}) \cdot \{ \vec{U} \times \vec{V} + \hat{k} \times (U_k \vec{V} - \vec{U} V_k) \} \quad (19a)$$

which we expand term by term and use standard three-dimensional space vector identities

$$\vec{U} \cdot (\vec{U} \times \vec{V}) = 0 \quad ; \quad \hat{k} \cdot \{ \hat{k} \times (U_k \vec{V} - \vec{U} V_k) \} = 0 \quad (19b)$$

to obtain

$$U \cdot (U \times V) = \hat{k} \cdot (U_k \vec{U} \times \vec{V}) + \vec{U} \cdot \{ \hat{k} \times (U_k \vec{V} - \vec{U} V_k) \} \quad (19c)$$

Applying a three-dimensional space vector identity

$$\vec{U} \cdot \{ \hat{k} \times (U_k \vec{V} - \vec{U} V_k) \} = \hat{k} \cdot \{ (U_k \vec{V} - \vec{U} V_k) \times \vec{U} \} \quad (19d)$$

and using

$$\vec{U} V_k \times \vec{U} = V_k \vec{U} \times \vec{U} = 0 \quad (19e)$$

gives

$$\vec{U} \cdot \{ \hat{k} \times (U_k \vec{V} - \vec{U} V_k) \} = -\hat{k} \cdot (U_k \vec{U} \times \vec{V}) \quad (19f)$$

which we substitute into equation (15c) to obtain the final result

$$U \cdot (U \times V) = 0 \quad (19g)$$

This result generalizes the divergence of curl of a four-vector obtained in equation (18). It is a generalization of the corresponding vector identity in standard three-dimensional Euclidean space given in the first part of equation (19b).

### d) *Divergence and curl of $f V$*

For a scalar function  $f(\vec{r}, t)$ , we use the definitions of  $\nabla$  and  $V$  from equations (6a) and (8a) to obtain

$$\nabla \cdot (fV) = \left(\frac{i}{c} \frac{\partial}{\partial t} \hat{k} + \vec{\nabla}\right) \cdot \{f(V_k \hat{k} + \vec{V})\} ; \nabla \times (fV) = \left(\frac{i}{c} \frac{\partial}{\partial t} \hat{k} + \vec{\nabla}\right) \times \{f(V_k \hat{k} + \vec{V})\} \quad (20a)$$

Expanding these term by term gives

$$\nabla \cdot (fV) = \left(\frac{i}{c} \frac{\partial f}{\partial t} \hat{k} + \vec{\nabla}f\right) \cdot V_k \hat{k} + \left(\frac{i}{c} \frac{\partial f}{\partial t} \hat{k} + \vec{\nabla}f\right) \cdot \vec{V} + f \left(\frac{i}{c} \frac{\partial}{\partial t} \hat{k} + \vec{\nabla}\right) \cdot V_k \hat{k} + f \left(\frac{i}{c} \frac{\partial}{\partial t} \hat{k} + \vec{\nabla}\right) \cdot \vec{V} \quad (20b)$$

$$\nabla \times (fV) = \left(\frac{i}{c} \frac{\partial f}{\partial t} \hat{k} + \vec{\nabla}f\right) \times V_k \hat{k} + \left(\frac{i}{c} \frac{\partial f}{\partial t} \hat{k} + \vec{\nabla}f\right) \times \vec{V} + f \left(\frac{i}{c} \frac{\partial}{\partial t} \hat{k} + \vec{\nabla}\right) \times V_k \hat{k} + f \left(\frac{i}{c} \frac{\partial}{\partial t} \hat{k} + \vec{\nabla}\right) \times \vec{V} \quad (20c)$$

which we reorganize to obtain the four-vector identities

$$\nabla \cdot (fV) = \nabla f \cdot V + f \nabla \cdot V ; \nabla \times (fV) = \nabla f \times V + f \nabla \times V \quad (20d)$$

These four-vector identities generalize the corresponding vector identities in standard three-dimensional Euclidean space.

**e) Divergence of four-vector cross product:**  $\nabla \cdot (U \times V)$

We use the general form of the curl of a four-vector from equation (14) to obtain

$$U \cdot \nabla \times V = \vec{U} \cdot \vec{\nabla} \times \vec{V} - i \hat{k} \cdot \{c \varphi \vec{\nabla} \times \vec{V} + \left(\frac{1}{c} \frac{\partial \vec{V}}{\partial t} + \vec{\nabla}(c\Lambda)\right) \times \vec{U}\} \quad (21a)$$

$$V \cdot \nabla \times U = \vec{V} \cdot \vec{\nabla} \times \vec{U} - i \hat{k} \cdot \{c \Lambda \vec{\nabla} \times \vec{U} + \left(\frac{1}{c} \frac{\partial \vec{U}}{\partial t} + \vec{\nabla}(c\varphi)\right) \times \vec{V}\} \quad (21b)$$

after applying standard three-dimensional space vector identities

$$\hat{k} \cdot \left(\frac{1}{c} \frac{\partial \vec{V}}{\partial t} + \vec{\nabla}(c\Lambda)\right) \times \hat{k} = 0 ; \hat{k} \cdot \left(\frac{1}{c} \frac{\partial \vec{U}}{\partial t} + \vec{\nabla}(c\varphi)\right) \times \hat{k} = 0 \quad (21c)$$

$$\vec{U} \cdot \left(\frac{1}{c} \frac{\partial \vec{V}}{\partial t} + \vec{\nabla}(c\Lambda)\right) \times \hat{k} = \hat{k} \cdot \left(\frac{1}{c} \frac{\partial \vec{V}}{\partial t} + \vec{\nabla}(c\Lambda)\right) \times \vec{U} \quad (21d)$$

$$\vec{V} \cdot \left(\frac{1}{c} \frac{\partial \vec{U}}{\partial t} + \vec{\nabla}(c\varphi)\right) \times \hat{k} = \hat{k} \cdot \left(\frac{1}{c} \frac{\partial \vec{U}}{\partial t} + \vec{\nabla}(c\varphi)\right) \times \vec{V} \quad (21e)$$

Subtracting equation (21b) from equation (21a) and applying standard three-dimensional vector identities, together with appropriate rules of differentiation of vector products, we obtain the final result

$$V \cdot \nabla \times U - U \cdot \nabla \times V = \vec{\nabla} \cdot \vec{U} \times \vec{V} + i \hat{k} \cdot \left\{ \frac{1}{c} \frac{\partial}{\partial t} (\vec{U} \times \vec{V}) + \vec{\nabla} \times (c\varphi \vec{V}) - \vec{\nabla} \times (c\Lambda \vec{U}) \right\} \quad (21f)$$

We now use the four-vector cross product from equation (8b) to obtain

$$\nabla \cdot U \times V = \left(\frac{i}{c} \frac{\partial}{\partial t} \hat{k} + \vec{\nabla}\right) \cdot (\vec{U} \times \vec{V} - i c \hat{k} \times (\varphi \vec{V} - \Lambda \vec{U})) \quad (22a)$$

which we expand as appropriate and apply standard three-dimensional space vector identities

$$\hat{k} \cdot \hat{k} \times (\varphi \vec{V} - \Lambda \vec{U}) = 0 ; \vec{\nabla} \cdot \hat{k} \times (\varphi \vec{V} - \Lambda \vec{U}) = -\hat{k} \cdot \vec{\nabla} \times (\varphi \vec{V} - \Lambda \vec{U}) \quad (22b)$$

to obtain the final result

$$\nabla \cdot U \times V = \vec{\nabla} \cdot \vec{U} \times \vec{V} + i \hat{k} \cdot \left\{ \frac{1}{c} \frac{\partial}{\partial t} (\vec{U} \times \vec{V}) + \vec{\nabla} \times (c\varphi \vec{V}) - \vec{\nabla} \times (c\Lambda \vec{U}) \right\} \quad (22c)$$

Substituting equation (21f) into equation (22c) gives the four-vector identity

$$\nabla \cdot (U \times V) = V \cdot (\nabla \times U) - U \cdot (\nabla \times V) \quad (22d)$$

This four-vector identity generalizes the corresponding vector identity in standard three-dimensional Euclidean space given earlier in equation (17e).

**f) The curl of curl a four-vector:**  $\nabla \times (\nabla \times V)$

Let us start by taking the four-vector curl of the curl of the general complex four-vector in equation (14) to obtain

$$\nabla \times (\nabla \times V) = \left( \frac{i}{c} \frac{\partial}{\partial t} \hat{k} + \vec{\nabla} \right) \times (\vec{\nabla} \times \vec{V} + i\hat{k} \times \left( \frac{1}{c} \frac{\partial \vec{V}}{\partial t} + \vec{\nabla}(c\Lambda) \right)) \quad (23a)$$

which we on expansion takes the form

$$\begin{aligned} \nabla \times (\nabla \times V) = & i\hat{k} \times \left( \vec{\nabla} \times \frac{1}{c} \frac{\partial \vec{V}}{\partial t} \right) - \frac{1}{c} \frac{\partial}{\partial t} \hat{k} \times \left\{ \hat{k} \times \left( \frac{1}{c} \frac{\partial \vec{V}}{\partial t} + \vec{\nabla}(c\Lambda) \right) \right\} \\ & + \vec{\nabla} \times (\vec{\nabla} \times \vec{V}) + i\vec{\nabla} \times \left\{ \hat{k} \times \left( \frac{1}{c} \frac{\partial \vec{V}}{\partial t} + \vec{\nabla}(c\Lambda) \right) \right\} \end{aligned} \quad (23b)$$

Next, we take the four-vector gradient of the divergence of the general complex four-vector in equation (13c) to obtain

$$\nabla(\nabla \cdot V) = \left( \frac{i}{c} \frac{\partial}{\partial t} \hat{k} + \vec{\nabla} \right) \left( \frac{\partial \Lambda}{\partial t} + \vec{\nabla} \cdot \vec{V} + i\hat{k} \cdot \left( \frac{1}{c} \frac{\partial \vec{V}}{\partial t} - \vec{\nabla}(c\Lambda) \right) \right) \quad (23c)$$

which we expand in the form

$$\begin{aligned} \nabla(\nabla \cdot V) = & \frac{i}{c} \frac{\partial}{\partial t} \hat{k} \left( \frac{\partial \Lambda}{\partial t} + \vec{\nabla} \cdot \vec{V} \right) - \frac{1}{c} \frac{\partial}{\partial t} \hat{k} \cdot \left\{ \hat{k} \cdot \left( \frac{1}{c} \frac{\partial \vec{V}}{\partial t} - \vec{\nabla}(c\Lambda) \right) \right\} \\ & + \vec{\nabla} \left( \frac{\partial \Lambda}{\partial t} + \vec{\nabla} \cdot \vec{V} \right) + i\vec{\nabla} \cdot \left\{ \hat{k} \cdot \left( \frac{1}{c} \frac{\partial \vec{V}}{\partial t} - \vec{\nabla}(c\Lambda) \right) \right\} \end{aligned} \quad (23d)$$

I apply standard three-dimensional Euclidean space vector identities giving

$$\begin{aligned} \hat{k} \times \left\{ \hat{k} \times \left( \frac{1}{c} \frac{\partial \vec{V}}{\partial t} - \vec{\nabla}(c\Lambda) \right) \right\} = & \hat{k} \cdot \hat{k} \cdot \left( \frac{1}{c} \frac{\partial \vec{V}}{\partial t} - \vec{\nabla}(c\Lambda) \right) - \left( \frac{1}{c} \frac{\partial \vec{V}}{\partial t} - \vec{\nabla}(c\Lambda) \right) \\ \frac{1}{c} \frac{\partial}{\partial t} \hat{k} \cdot \left\{ \hat{k} \cdot \left( \frac{1}{c} \frac{\partial \vec{V}}{\partial t} - \vec{\nabla}(c\Lambda) \right) \right\} = & \frac{1}{c} \frac{\partial}{\partial t} \hat{k} \times \left\{ \hat{k} \times \left( \frac{1}{c} \frac{\partial \vec{V}}{\partial t} - \vec{\nabla}(c\Lambda) \right) \right\} + \frac{1}{c} \frac{\partial}{\partial t} \left( \frac{1}{c} \frac{\partial \vec{V}}{\partial t} - \vec{\nabla}(c\Lambda) \right) \end{aligned} \quad (23e)$$

$$\vec{\nabla} \cdot \left\{ \hat{k} \cdot \left( \frac{1}{c} \frac{\partial \vec{V}}{\partial t} - \vec{\nabla}(c\Lambda) \right) \right\} = \hat{k} \times (\vec{\nabla} \times \frac{1}{c} \frac{\partial \vec{V}}{\partial t}) + (\hat{k} \cdot \vec{\nabla}) \left( \frac{1}{c} \frac{\partial \vec{V}}{\partial t} - \vec{\nabla}(c\Lambda) \right) \quad (23f)$$

$$\vec{\nabla}(\vec{\nabla} \cdot \vec{V}) = \vec{\nabla} \times (\vec{\nabla} \times \vec{V}) + \vec{\nabla}^2 \vec{V} \quad (23g)$$

which we substitute into equation (23d) as appropriate to obtain the final form

$$\begin{aligned} \nabla(\nabla \cdot V) = & \frac{i}{c} \frac{\partial}{\partial t} \hat{k} \left( \frac{\partial \Lambda}{\partial t} + \vec{\nabla} \cdot \vec{V} \right) + \vec{\nabla} \frac{\partial \Lambda}{\partial t} + \vec{\nabla} \times (\vec{\nabla} \times \vec{V}) + \vec{\nabla}^2 \vec{V} - \frac{1}{c} \frac{\partial}{\partial t} \hat{k} \times \left\{ \hat{k} \times \left( \frac{1}{c} \frac{\partial \vec{V}}{\partial t} - \vec{\nabla}(c\Lambda) \right) \right\} \\ & - \frac{1}{c} \frac{\partial}{\partial t} \left( \frac{1}{c} \frac{\partial \vec{V}}{\partial t} - \vec{\nabla}(c\Lambda) \right) + i\hat{k} \times (\vec{\nabla} \times \frac{1}{c} \frac{\partial \vec{V}}{\partial t}) + i(\hat{k} \cdot \vec{\nabla}) \left( \frac{1}{c} \frac{\partial \vec{V}}{\partial t} - \vec{\nabla}(c\Lambda) \right) \end{aligned} \quad (23h)$$

Subtracting equation (23b) from equation (23h) and using standard three-dimensional Euclidean space vector identities giving

$$\vec{\nabla} \times \left\{ \hat{k} \times \left( \frac{1}{c} \frac{\partial \vec{V}}{\partial t} + \vec{\nabla}(c\Lambda) \right) \right\} = \left\{ \vec{\nabla} \cdot \left( \frac{1}{c} \frac{\partial \vec{V}}{\partial t} + \vec{\nabla}(c\Lambda) \right) \right\} \hat{k} - (\hat{k} \cdot \vec{\nabla}) \left( \frac{1}{c} \frac{\partial \vec{V}}{\partial t} + \vec{\nabla}(c\Lambda) \right) \quad (24a)$$

$$\hat{k} \times (\hat{k} \times \vec{\nabla}(c\Lambda)) = (\hat{k} \cdot \vec{\nabla}(c\Lambda)) \hat{k} - \vec{\nabla}(c\Lambda) \quad (24b)$$

We obtain

$$\begin{aligned} \nabla(\nabla \cdot V) - \nabla \times (\nabla \times V) &= \frac{i}{c} \frac{\partial}{\partial t} \hat{k} \left( \frac{\partial \Lambda}{\partial t} + \vec{\nabla} \cdot \vec{V} \right) + \vec{\nabla}^2 \vec{V} - \frac{1}{c^2} \frac{\partial^2 \vec{V}}{\partial t^2} + \frac{2}{c} \frac{\partial}{\partial t} (\hat{k} \cdot \vec{\nabla})(c\Lambda \hat{k} + i\vec{V}) \\ &\quad - i \left\{ \vec{\nabla} \cdot \left( \frac{1}{c} \frac{\partial \vec{V}}{\partial t} + \vec{\nabla}(c\Lambda) \right) \right\} \hat{k} \end{aligned} \quad (24c)$$

Which on reorganizing

$$\left\{ \vec{\nabla} \cdot \left( \frac{1}{c} \frac{\partial \vec{V}}{\partial t} + \vec{\nabla}(c\Lambda) \right) \right\} \hat{k} = \left\{ \frac{1}{c} \frac{\partial (\vec{\nabla} \cdot \vec{V})}{\partial t} + \vec{\nabla}^2(c\Lambda) \right\} \hat{k} \quad ; \quad c\Lambda \hat{k} + i\vec{V} = i(-ic\Lambda \hat{k} + \vec{V}) = iV \quad (24d)$$

Takes the form

$$\nabla(\nabla \cdot V) - \nabla \times (\nabla \times V) = i \left( \frac{1}{c^2} \frac{\partial^2 (c\Lambda)}{\partial t^2} - \vec{\nabla}^2(c\Lambda) \right) \hat{k} + (\vec{\nabla}^2 \vec{V} - \frac{1}{c^2} \frac{\partial^2 \vec{V}}{\partial t^2}) + 2i(\hat{k} \cdot \vec{\nabla}) \frac{1}{c} \frac{\partial V}{\partial t} \quad (24e)$$

We easily obtain

$$i \left( \frac{1}{c^2} \frac{\partial^2 (c\Lambda)}{\partial t^2} - \vec{\nabla}^2(c\Lambda) \right) \hat{k} + (\vec{\nabla}^2 \vec{V} - \frac{1}{c^2} \frac{\partial^2 \vec{V}}{\partial t^2}) = (\vec{\nabla}^2 - \frac{1}{c^2} \frac{\partial^2}{\partial t^2})(-ic\Lambda \hat{k} + \vec{V}) = (\vec{\nabla}^2 - \frac{1}{c^2} \frac{\partial^2}{\partial t^2})V \quad (24f)$$

Which we substitute into equation (24c) to obtain

$$\nabla(\nabla \cdot V) - \nabla \times (\nabla \times V) = (\vec{\nabla}^2 - \frac{1}{c^2} \frac{\partial^2}{\partial t^2} + 2i(\hat{k} \cdot \vec{\nabla}) \frac{1}{c} \frac{\partial}{\partial t})V \quad (24g)$$

Setting

$$U = V = \nabla \Rightarrow \varphi = \Lambda = -\frac{1}{c^2} \frac{\partial}{\partial t} \quad ; \quad \vec{U} = \vec{V} = \vec{\nabla} \quad (25a)$$

in the general four-vector dot product in equation (11c) gives

$$\nabla \cdot \nabla = \nabla^2 = \vec{\nabla}^2 - \frac{1}{c^2} \frac{\partial^2}{\partial t^2} + 2i(\hat{k} \cdot \vec{\nabla}) \frac{1}{c} \frac{\partial}{\partial t} \quad (25b)$$

which we substitute into equation (24e) and reorganize to obtain the four-vector identity

$$\nabla \times (\nabla \times V) = \nabla(\nabla \cdot V) - \nabla^2 V \quad (26)$$

This four-vector identity generalizes the corresponding vector identity in standard three-dimensional Euclidean space given earlier in equation (23g).

The four-vector identities derived in equations (16) , (18) , (19g) , (20d) , (22d) and (26) confirm the consistency of the definitions of the complex four-component vectors and corresponding mathematical operations within the complex four-dimensional spacetime frame. This means that complex four-dimensional spacetime frame characterized by complex four-component vectors is a consistent mathematical extension of the standard three-dimensional Euclidean space characterized by the usual three-component vectors. The other four-vector identities can be derived following similar procedure.

### Physics in the complex spacetime frame

In this section, we study some of the physical consequences of the dynamics based on the mathematical operations with complex four-vectors defined within the fully specified four-dimensional complex spacetime frame with an imaginary temporal axis, noting that the complex four-vectors represent physical quantities which characterize the dynamics of a system. General dynamics in the spacetime frame is described as events characterized by the transfer of energy and momentum at various spacetime points. These events are governed by spacetime evolution equations which ensure conservation of fundamental physical quantities such as electric charge, mass and energy.

#### *Event interval and the basic dynamical four-vectors*

The separation in time and space between events at two neighboring spacetime points constitutes the event interval, which is represented by an infinitesimal spacetime

displacement four-vector  $dX$ . The general complex spacetime displacement four-vector  $X$  is defined by

$$X = x_k \hat{k} + \vec{r} = -ict \hat{k} + \vec{r} ; x_k = -ict \quad (27a)$$

where  $\vec{r}$  is the position vector defined as usual. The event interval  $dX$  is obtained as

$$dX = dx_k \hat{k} + d\vec{r} = -icdt \hat{k} + d\vec{r} ; dx_k = -icdt \quad (27b)$$

The basic dynamical four-vectors are the linear momentum (or energy-momentum)  $P$ , electric current density  $J$ , the field potential  $A$  and the wave vector  $K$ , which are defined in relation to the general complex four-vector  $V$  in equation (8a) in the form

$$P = p_k \hat{k} + \vec{p} = -imc \hat{k} + \vec{p} ; V = P \Rightarrow \Lambda = m , \vec{V} = \vec{p} \quad (27c)$$

$$J = j_k \hat{k} + \vec{J} = -ic\rho \hat{k} + \vec{J} ; V = J \Rightarrow \Lambda = \rho , \vec{V} = \vec{J} \quad (27d)$$

$$A = A_k \hat{k} + \vec{A} = -ic\phi \hat{k} + \vec{A} ; V = A \Rightarrow \Lambda = \phi , \vec{V} = \vec{A} \quad (27e)$$

$$K = -i\frac{\omega}{c} \hat{k} + \vec{k} = -ic\left(\frac{\omega}{c^2}\right) \hat{k} + \vec{k} ; V = K \Rightarrow \Lambda = \frac{\omega}{c^2} , \vec{V} = \vec{k} \quad (27f)$$

We observe that the basic mathematical operator for describing dynamics in the complex spacetime frame is the complex spacetime derivative four-vector  $\nabla$  defined in equation (6a). General features of dynamics in a complex spacetime frame can be developed using the general complex four-vector  $V$  and the complex spacetime derivative four-vector  $\nabla$ .

### ***Unified field intensity in a complex spacetime frame***

Rewriting the curl of the general four-vector  $V$  in equation (14) in the form

$$\nabla \times V = \vec{\nabla} \times \vec{V} + i\left(-\frac{1}{c} \frac{\partial \vec{V}}{\partial t} - \vec{\nabla}(c\Lambda)\right) \times \hat{k} \quad (28a)$$

we introduce general field intensities  $\vec{R}$  and  $\vec{Q}$  characterizing dynamics in a general spacetime frame defined by

$$\vec{R} = \vec{\nabla} \times \vec{V} ; \vec{Q} = -\frac{1}{c} \frac{\partial \vec{V}}{\partial t} - \vec{\nabla}(c\Lambda) \quad (28b)$$

to express the curl of the general four-vector in the form

$$\nabla \times V = \vec{R} + i\vec{Q} \times \hat{k} \quad (28c)$$

This is an important result which shows that the curl of the general complex four-vector  $V$  generates a unified complex field intensity  $\vec{F}$  composed of two basic field intensities  $\vec{R}$  and  $\vec{Q}$  obtained in the form

$$\vec{F} = \nabla \times V \Rightarrow \vec{F} = \vec{R} + i\vec{Q} \times \hat{k} \quad (28d)$$

The general nature of the curl of a general four-vector as presented in equations (28a)-(28d) presents important physical implications for dynamics characterized by quantities which are generally expressed as complex four-vectors within the complex four-dimensional spacetime frame. We illustrate some of these consequences using electromagnetic and gravitational fields as examples below.

For dynamics in an electromagnetic field characterized by the field potential four-vector  $A$ , setting  $V = A$  in equations (28a)-(28d) then means that the curl of the electromagnetic field potential four-vector generates the familiar magnetic and electric field intensities  $\vec{B}$  and  $\vec{E}$  obtained by setting  $\vec{R} = \vec{B}, \vec{Q} = \vec{E}, \vec{V} = \vec{A}, \Lambda = \phi$  in equation (28b) giving the usual definitions

$$\vec{B} = \vec{\nabla} \times \vec{A} ; \vec{E} = -\vec{\nabla}(c\phi) - \frac{1}{c} \frac{\partial \vec{A}}{\partial t} \quad (29a)$$

The total electromagnetic field intensity follows from the unified field intensity in equation (28d) as

$$\vec{F} = \vec{B} + i\vec{E} \times \hat{k} \quad (29b)$$

Two other four-vectors in a general electromagnetic field are the electric current density  $J$  defined in equation (27d) and the Poynting four-vector  $S$  which we define here as

$$S = S_k \hat{k} + \vec{S} = -ic\xi \hat{k} + \vec{S} ; \xi = \frac{1}{2}(\vec{E} \cdot \vec{E} + \vec{B} \cdot \vec{B}) ; \vec{S} = c\vec{E} \times \vec{B} \quad (29c)$$

where  $\xi$  is the electromagnetic field energy density and  $\vec{S}$  is the Poynting vector defined as usual.

Setting  $V = J, S$  in equations (28a)-(28d) gives current density and Poynting vector associated "field intensities" obtained as

$$V = J : \vec{R} = \vec{\nabla} \times \vec{J} , \vec{Q} = -\vec{\nabla}(c\rho) - \frac{1}{c} \frac{\partial \vec{J}}{\partial t} \quad (29d)$$

$$V = S : \vec{R} = \vec{\nabla} \times \vec{S} ; \vec{Q} = -\vec{\nabla}(c\xi) - \frac{1}{c} \frac{\partial \vec{S}}{\partial t} \quad (29e)$$

The similarity of the field intensities in equations (29a), (29d) and (29e) means that they obey the same types of field equations, such as Maxwell and wave equations governed by the same physical laws within the electromagnetic field.

A very important implication of the general form of equations (28a)-(28d) follows from the fact the general four-vector  $V$  can be a gravitational field potential in the complex spacetime frame. In such a case, equation (28c) then shows that the curl of the gravitational field potential four-vector provides two components of the gravitational field intensity, one component being the familiar Newtonian gravitational field intensity  $\vec{g}$  specified by  $\vec{Q} = \vec{g}$  and the other component may be interpreted as a *gravitational field induction*  $\vec{d}$  specified by  $\vec{R} = \vec{d}$  in equation (28b) responsible for deflection or rotation of masses within the gravitational field, with  $\Lambda$  and

$\vec{V}$  then representing appropriately defined gravitational scalar and vector potentials, respectively, giving

$$\vec{d} = \vec{\nabla} \times \vec{V} ; \vec{g} = -\vec{\nabla}(c\Lambda) - \frac{1}{c} \frac{\partial \vec{V}}{\partial t} \quad (29f)$$

The total gravitational field intensity follows from equation (28d) as

$$\vec{F} = \vec{d} + i\vec{g} \times \hat{k} \quad (29g)$$

In this respect, the Newtonian gravity intensity  $\vec{g}$  corresponds to the electric field intensity  $\vec{E}$ , while the gravity deflection intensity  $\vec{d}$  corresponds to the magnetic field induction  $\vec{B}$  in an electromagnetic field. This general result is consistent with usual results obtained in the linearized form of Einstein's field equations in the weak gravitational field limit of the general theory of relativity.

#### **a) General field Lagrange and energy density in a complex spacetime frame**

The unified field intensity  $\vec{F}$  defined in equation (28a) provides the general field Lagrange density  $L_a$  and energy density  $E_a$  according to

$$L_d = -\frac{1}{2} \vec{F} \cdot \vec{F} = \frac{1}{2} \{ \vec{Q}^2 - \vec{R}^2 - (\hat{k} \cdot \vec{Q})^2 \} - i \hat{k} \cdot (\vec{R} \times \vec{Q}) ; E_d = \vec{F}^* \cdot \vec{F} = \frac{1}{2} \{ \vec{Q}^2 + \vec{R}^2 - (\hat{k} \cdot \vec{Q})^2 \} \quad (29h)$$

where we have applied standard three-dimensional Euclidean space vector identities to obtain the final forms. We use the general definition of the unified field intensity  $\vec{F} = \nabla \times V$  to express the Lagrange and energy densities in the curl forms

$$L_d = -\frac{1}{2} (\nabla \times V) \cdot (\nabla \times V) ; E_d = \frac{1}{2} (\nabla \times V)^* \cdot (\nabla \times V) \quad (29i)$$

where we have used complex conjugation as appropriate in the definition of the field energy density.

### **General field equations in a complex spacetime frame**

We now proceed to derive general field equations governing dynamics in a complex spacetime frame specified by general intensities  $\vec{R}, \vec{Q}$  derived from the general complex four-vector  $V$  according to equation (28b).

We take the divergence ( $\vec{\nabla} \cdot$ ) of  $\vec{R}, \vec{Q}$  in equation (28b) and apply standard vector identities in three-dimensional space as appropriate to obtain

$$\vec{\nabla} \cdot \vec{R} \quad (30)$$

$$\frac{1}{c} \vec{\nabla} \cdot \vec{Q} = -\frac{1}{c^2} \frac{\partial \vec{\nabla} \cdot \vec{V}}{\partial t} - \vec{\nabla}^2 \Lambda \quad (31a)$$

Noting that the term  $-\vec{\nabla}^2 \Lambda$  represents the spatial component of a wave propagation equation for  $\Lambda$  as compared to equation (1), we add and subtract the temporal component

$$\frac{1}{c^2} \frac{\partial^2 \Lambda}{\partial t^2}$$

to write equation (31a) in the form

$$\frac{1}{c^2} \frac{\partial^2 \Lambda}{\partial t^2} - \vec{\nabla}^2 \Lambda - \frac{1}{c^2} \frac{\partial}{\partial t} \left( \frac{\partial \Lambda}{\partial t} + \vec{\nabla} \cdot \vec{V} \right) = \frac{1}{c} \vec{\nabla} \cdot \vec{Q} \quad (31b)$$

where we have rearranged

$$-\frac{1}{c^2} \frac{\partial \vec{\nabla} \cdot \vec{V}}{\partial t} - \frac{1}{c^2} \frac{\partial^2 \Lambda}{\partial t^2} = -\frac{1}{c^2} \frac{\partial}{\partial t} \left( \frac{\partial \Lambda}{\partial t} + \vec{\nabla} \cdot \vec{V} \right) \quad (31c)$$

Next, we take the curl of  $\vec{R}$ , apply the temporal derivative operator  $\frac{1}{c} \frac{\partial}{\partial t}$  on  $\vec{Q}$  in equation

(24b) and then use standard three-dimensional space vector identities to obtain

$$\vec{\nabla} \times \vec{R} = \vec{\nabla} \times \vec{\nabla} \times \vec{V} = \vec{\nabla} (\vec{\nabla} \cdot \vec{V}) - \vec{\nabla}^2 \vec{V} \quad (31d)$$

$$\frac{1}{c} \frac{\partial \vec{Q}}{\partial t} = -\vec{\nabla} \frac{\partial \Lambda}{\partial t} - \frac{1}{c^2} \frac{\partial^2 \vec{V}}{\partial t^2} \quad (31e)$$

Subtracting equation (28b) from equation (28a) and reorganizing gives

$$\frac{1}{c^2} \frac{\partial^2 \vec{V}}{\partial t^2} - \vec{\nabla}^2 \vec{V} + \vec{\nabla} \left( \frac{\partial \Lambda}{\partial t} + \vec{\nabla} \cdot \vec{V} \right) = \vec{\nabla} \times \vec{R} - \frac{1}{c} \frac{\partial \vec{Q}}{\partial t} \quad (31f)$$

Finally, we take the curl of  $\vec{Q}$  in equation (28b) and use the definition of  $\vec{R}$  from the same equation to obtain

$$\vec{\nabla} \times \vec{Q} = -\frac{1}{c} \frac{\partial \vec{R}}{\partial t} \quad (31h)$$

We observe that equations (31b) and (31f) are general forms of wave propagation equations for the temporal and vector components  $\Lambda$  and  $\vec{V}$  of the general complex four-vector  $V$  defined in equation (8a). Noting that the divergence of a vector or time derivative of a

scalar generates a scalar quantity, while the curl or time derivative of a vector generates a vector quantity, we introduce scalar quantities  $\sigma(\vec{r}, t)$ ,  $\chi(\vec{r}, t)$  and a vector quantity  $\vec{q}(\vec{r}, t)$  obtained as the driving terms in the wave equations (31b) and (31f) according to

$$\vec{\nabla} \cdot \vec{Q} = \sigma \quad ; \quad \vec{\nabla} \times \vec{R} - \frac{1}{c} \frac{\partial \vec{Q}}{\partial t} = \frac{1}{c} \vec{q} \quad (32a)$$

$$\frac{\partial \Lambda}{\partial t} + \vec{\nabla} \cdot \vec{V} = c\chi \quad (32b)$$

Taking the divergence of the second equation of equation (32a), applying a standard vector identity and using the first equation of (32a) in the result gives

$$\frac{\partial \sigma}{\partial t} + \vec{\nabla} \cdot \vec{q} = 0 \quad (32c)$$

which combines the scalar  $\sigma(\vec{r}, t)$  and vector  $\vec{q}(\vec{r}, t)$  as the temporal and spatial components of a complex four-vector  $q(\vec{r}, t)$  defined within the complex spacetime frame as

$$q = q_k \hat{k} + \vec{q} = -ic\sigma \hat{k} + \vec{q} \quad (32d)$$

Substituting equations (32a)-(32b) into equations (31b) and (31f) as appropriate, we obtain the general wave equations for the complex four-vector  $V$  in the final form

$$\frac{1}{c^2} \frac{\partial^2 \Lambda}{\partial t^2} - \vec{\nabla}^2 \Lambda = \frac{1}{c} \frac{\partial \chi}{\partial t} + \frac{1}{c} \sigma \quad ; \quad \frac{1}{c^2} \frac{\partial^2 \vec{V}}{\partial t^2} - \vec{\nabla}^2 \vec{V} = -\vec{\nabla}(c\chi) + \frac{1}{c} \vec{q} \quad (33)$$

We interpret  $\sigma$  as a *source charge density* and  $\vec{q}$  as the corresponding *source current density*, which generate the complex four-vector  $V$  according to the wave equations in (33).

For ease of reference, we collect equations (8a), (28b), (28c), (30), (31h) and (32a) together to present the basic equations of dynamics in a field generated by a general complex four-vector  $V$  within a complex spacetime frame in the final forms

$$V = -ic\Lambda \hat{k} + \vec{V} \quad ; \quad \nabla \times V = \vec{R} + i\vec{Q} \times \hat{k} \quad ; \quad \vec{Q} = -\vec{\nabla}(c\Lambda) - \frac{1}{c} \frac{\partial \vec{V}}{\partial t} \quad ; \quad \vec{R} = \vec{\nabla} \times \vec{V} \quad (34a)$$

$$\vec{\nabla} \cdot \vec{Q} = \sigma \quad ; \quad \vec{\nabla} \times \vec{Q} = -\frac{1}{c} \frac{\partial \vec{R}}{\partial t} \quad ; \quad \vec{\nabla} \cdot \vec{R} = 0 \quad ; \quad \vec{\nabla} \times \vec{R} = \frac{1}{c} \frac{\partial \vec{Q}}{\partial t} + \frac{1}{c} \vec{q} \quad ; \quad \frac{\partial \sigma}{\partial t} + \vec{\nabla} \cdot \vec{q} = 0 \quad (34b)$$

$$\frac{1}{c^2} \frac{\partial^2 \Lambda}{\partial t^2} - \vec{\nabla}^2 \Lambda = \frac{1}{c} \frac{\partial \chi}{\partial t} + \frac{1}{c} \sigma \quad ; \quad \frac{1}{c^2} \frac{\partial^2 \vec{V}}{\partial t^2} - \vec{\nabla}^2 \vec{V} = -\vec{\nabla}(c\chi) + \frac{1}{c} \vec{q} \quad ; \quad \frac{\partial \Lambda}{\partial t} + \vec{\nabla} \cdot \vec{V} = c\chi \quad (34c)$$

These space-time evolution equations apply in any dynamical field (i.e., force field) characterized by a general complex potential four-vector  $V$  generated by matter sources such as electric charge or mass of complex current density four-vector  $q$  defined in equation (32d). The continuity equation for  $q$  in equations (32c) and (34b) governs the conservation of the field producing matter, e.g., electric charge conservation in an electromagnetic field or mass/energy conservation in a gravitational field.

The set of equations in (34b)-(34c), together with the general definitions of field intensities in equation (34a), show that dynamics in both electromagnetic ( $V = A, \vec{Q} = \vec{E}, \vec{R} = \vec{B}, q = J$ ) and gravitational ( $V = U, \vec{Q} = \vec{g}, \vec{R} = \vec{d}, q = P$ ) fields is governed by the same forms of Maxwell-type and wave equations within a complex spacetime frame. The wave equations in (30c) are governed by a general form of continuity equation in equations (32b) and (34c), which reduces to the familiar Lorentz gauge condition of standard electrodynamics in the special case  $\chi = 0$



$$\chi = 0 ; \frac{\partial \Lambda}{\partial t} + \vec{\nabla} \cdot \vec{V} = 0 \quad (34d)$$

We conclude that within the complex spacetime frame defined in this paper, dynamics is described through a general complex four-vector  $V(\vec{r}, t)$  with space and time varying components satisfying wave equations governed by a general gauge condition, a continuity equation for the generating sources and Maxwell type equations for the intensities generated through the curl of the general four-vector. These equations take exactly the same form for both electromagnetic and gravitational fields as explained above. As observed earlier, the resulting equations in the gravitational field case ( $V = U = -ic\phi\hat{k} + \vec{U}$ ) are consistent with usual results obtained in the linearized form of Einstein's field equations in the weak gravitational field limit of the general theory of relativity, popularly referred to as gravitoelectromagnetism [4-6].

### ***General matter-field interaction energy***

The interaction energy between matter charges of complex current density four-vector  $q$  and the dynamical field of general complex potential four-vector  $V$  is obtained as the four-vector dot product of  $q$  and  $V$  according to

$$E_{\text{int}} = q \cdot V \quad (34e)$$

which on substituting  $U = q, \phi = \sigma, \vec{U} = \vec{q}$  in the general four-vector dot product in equation (11c) takes the final form

$$E_{\text{int}} = \vec{q} \cdot \vec{V} - c^2 \sigma \Lambda - ic\hat{k} \cdot (\sigma \vec{V} + \Lambda \vec{q}) \quad (34f)$$

### ***Some fundamental physical consequences***

It is now quite clear that complex spacetime frame with an imaginary temporal axis specified by a unit vector in the direction of light (wave) propagation has more general dynamical features compared to usual dynamics within conventional real spacetime frame where the temporal axis is not fully specified. The mathematical operations with the complex four-vectors in the four-dimensional complex spacetime frame reveal additional information associated with the general orientation of the temporal unit vector relative to the spatial coordinates, as well as additional information hidden behind the imaginary temporal axis as we demonstrate below.

#### ***a) General field force***

In the dynamical field characterized by the general complex four-vector  $V$ , we define the general field force  $F$  as the cross product of the unified field intensity  $\vec{F}$  in equation (28d) and the general source current density four-vector  $q$  defined in equation (32d) in the form

$$F = q \times \vec{F} = q \times (\nabla \times V) \quad (35a)$$

giving

$$F = (-ic\sigma\hat{k} + \vec{q}) \times (\vec{R} + i\vec{Q} \times \hat{k}) \quad (35b)$$

which we expand term by term and reorganize to obtain

$$F = c\sigma\hat{k} \times (\vec{Q} \times \hat{k}) + \vec{q} \times \vec{R} + i\{c\sigma\vec{R} \times \hat{k} + \vec{q} \times (\vec{Q} \times \hat{k})\} \quad (35c)$$

Applying a standard vector identity gives

$$\hat{k} \times (\vec{Q} \times \hat{k}) = \vec{Q} - (\hat{k} \cdot \vec{Q})\hat{k} \quad (35d)$$

which we substitute into equation (31b) to obtain the general field force in the final form

$$F = c\sigma\vec{Q} + \vec{q} \times \vec{R} - c\sigma(\vec{k} \cdot \vec{Q})\vec{k} + i\{c\sigma\vec{R} \times \hat{k} + \vec{q} \times (\vec{Q} \times \hat{k})\} \quad (35e)$$

We notice that the real part of the general force in equation (35e) is composed of a Lorentz force term  $c\sigma\vec{Q} + \vec{q} \times \vec{R}$  and an additional term  $-c\sigma(\vec{k} \cdot \vec{Q})\vec{k}$  associated with the general orientation of the temporal unit vector  $\hat{k}$  relative to the spatial unit vectors  $\hat{x}, \hat{y}, \hat{z}$ . The imaginary part is a force  $c\sigma\vec{R} \times \hat{k} + \vec{q} \times (\vec{Q} \times \hat{k})$  acting in a plane perpendicular to the field intensities  $\vec{R}, \vec{Q}$  and the temporal unit vector  $\hat{k}$ .

In the case of an electromagnetic field, we set  $\sigma = \rho, \vec{q} = \vec{J}, \vec{Q} = \vec{E}, \vec{R} = \vec{B}$  in equation (35e) to obtain the general electromagnetic force within the complex spacetime frame in the form

$$F_{em} = c\rho\vec{E} + \vec{J} \times \vec{B} - c\rho(\hat{k} \cdot \vec{E})\hat{k} + i\{c\rho\vec{B} \times \hat{k} + \vec{J} \times (\vec{E} \times \hat{k})\} \quad (35f)$$

which is a generalization of the familiar Lorentz force  $c\rho\vec{E} + \vec{J} \times \vec{B}$  of standard electrodynamics in a conventional spacetime frame.

### **b) Energy due to work done by general field force**

The work done on source charges under the action of the general field force within the complex spacetime frame, which constitutes a material medium in this respect, is obtained as the dot product of the source current density four-vector  $q$  defined in equation (32d) and the general field force  $F$  obtained in equation (35e) according to

$$W = q \cdot F \quad (36a)$$

Using the definition of  $F$  from equation (35a) and applying the general vanishing four-vector dot product identity established earlier in equation (19g), we easily obtain

$$q \cdot F = q \cdot (q \times (\nabla \times V)) = 0 \quad (36b)$$

giving the final result for the general interaction energy to be

$$W = 0 \quad (36c)$$

As a consistency check, we use  $q$  and  $F$  from equations (32d) and (35e) to obtain

$$q \cdot F = (-ic\sigma\hat{k} + \vec{q}) \cdot (c\sigma\vec{Q} + \vec{q} \times \vec{R} - c\sigma(\hat{k} \cdot \vec{Q})\hat{k} + i(c\sigma\vec{R} \times \hat{k} + \vec{q} \times (\vec{Q} \times \hat{k}))) \quad (36d)$$

which on expanding term by term and dropping cancelling or vanishing terms takes the form

$$q \cdot F = c\sigma\{\vec{q} \cdot \vec{Q} - (\hat{k} \cdot \vec{Q})(\hat{k} \cdot \vec{q}) + \hat{k} \cdot (\vec{q} \times (\vec{Q} \times \hat{k})) + i(\vec{q} \cdot (\vec{R} \times \hat{k}) - \hat{k} \cdot (\vec{q} \times \vec{R}))\} \quad (36e)$$

Applying vector appropriate vector identities, we obtain

$$\vec{q} \cdot (\vec{R} \times \hat{k}) = \vec{k} \cdot (\vec{q} \times \vec{R}) \quad ; \quad \vec{q} \times (\vec{Q} \times \hat{k}) = (\hat{k} \cdot \vec{q})\vec{Q} - (\vec{q} \cdot \vec{Q})\hat{k} \quad (36f)$$

$$\hat{k} \cdot (\vec{q} \times (\vec{Q} \times \hat{k})) = (\hat{k} \cdot \vec{Q})(\hat{k} \cdot \vec{q}) - \vec{q} \cdot \vec{Q} \quad (36g)$$

which we substitute into equation (36e) to obtain the desired result

$$q \cdot F = 0 \quad (36h)$$

in agreement with the expected result in equation (36b).

The vanishing of the work done means that there is *no net energy transfer* occurring in the dynamics of matter charges under the action of the general field force  $F$  in a material medium within the complex spacetime frame. This is in complete contrast to the familiar case of dynamics under the Lorentz force in an electromagnetic field in a material medium in the usual real (Minkowski) spacetime frame where the dot product of the electric current density vector and the Lorentz force yields a non-vanishing energy transfer due to work done by the Lorentz force on the moving electric charges in the form  $\vec{J} \cdot \vec{E}$ .

**c) Angular momentum**

In the dynamics of a body of mass  $m$  at time  $t$  within the complex spacetime frame, we define the general angular momentum  $L$  as the cross product of the complex displacement four-vector  $X$  and linear momentum four-vector  $P$  defined in equations (27a) and (27c) according to

$$L = X \times P \quad (37a)$$

which on setting  $U = X$  ( $\varphi = t, \vec{U} = \vec{r}$ ),  $V = P$  ( $\Lambda = m, \vec{V} = \vec{p}$ ) in the general four-vector cross product in equation (12d) gives

$$L = \vec{r} \times \vec{p} + i(ct\vec{p} - mc\vec{r}) \times \hat{k} = \vec{L} + i\vec{N} \quad (37b)$$

where the real part  $\vec{L}$  is the usual orbital angular momentum defined in three-dimensional space, while the imaginary part  $\vec{N}$  is the temporal component obtained in the form

$$\vec{L} = \vec{r} \times \vec{p} \quad ; \quad \vec{N} = ct\vec{p} - mc\vec{r} \quad (37c)$$

**d) Invariant length of the spacetime event interval**

We use the definition of the complex spacetime event interval  $dX$  given in equation (27b) to obtain

$$(dX)^2 = dX \cdot dX = (d\vec{r})^2 - (cdt)^2 - i(2cdt\hat{k} \cdot d\vec{r}) \quad (38a)$$

The invariant length,  $ds$ , of the event interval is obtained as the modulus of equation (38a) in the form

$$(ds)^2 = |-(dX)^2| = \sqrt{1 + \frac{(2cdt\hat{k} \cdot d\vec{r})^2}{((cdt)^2 - (d\vec{r})^2)^2}} ((cdt)^2 - (d\vec{r})^2) \quad (38b)$$

Factoring out  $cdt$  and introducing the velocity  $\vec{v}$  and speed  $v$  defined by

$$\vec{v} = \frac{d\vec{r}}{dt} \quad ; \quad v = |\vec{v}| \quad (38c)$$

we express the invariant length of the event interval in equation (38b) in the final form

$$(ds)^2 = \eta((cdt)^2 - (d\vec{r})^2) \quad (38d)$$

where we have introduced a temporal-spatial axes general orientation modification factor  $\eta$  defined by

$$\eta = \sqrt{1 + \frac{4(\hat{k} \cdot \vec{v})^2}{c^2(1 - \frac{v^2}{c^2})^2}} \quad (38e)$$

Similar forms of the orientation dependent modifications of the invariant length of the spacetime event interval have also been obtained in works investigating space anisotropy within the framework of Finsler geometry [3-4].

**e) Time dilation**

We introduce the event interval  $dX_0$  in the rest frame defined by

$$dX_0 = -icd\tau\hat{k} \quad (39a)$$

where  $d\tau$  is the time duration measured in the rest frame. The invariant length of the event interval in the rest frame follows easily from equation (35a) in the form

$$(ds)^2 = |-(dX_0)^2| = (cd\tau)^2 \quad (39b)$$

Applying the invariance principle according to

$$(ds)^2 = |-(dX)^2| = |-(dX_0)^2| \quad (39c)$$

and using equations (34d) and (35b), we obtain the time dilation relation in the complex four-dimensional spacetime frame in the final form

$$dt = \eta^{-\frac{1}{2}} \gamma d\tau \quad ; \quad \gamma = \frac{1}{\sqrt{1 - \frac{v^2}{c^2}}} \quad (39d)$$

which modifies the usual result obtained in Einstein's special theory of relativity by a temporal-spatial orientation factor  $\eta^{-\frac{1}{2}}$ .

### f) Mass increase

Introducing velocity  $\vec{v}$  to define the linear momentum four-vector  $P$  in equation (27c) in the form

$$P = -imc\hat{k} + m\vec{v} \quad (40a)$$

we obtain

$$P^2 = P \cdot P = m^2 v^2 - m^2 c^2 - i(2cm^2 \hat{k} \cdot \vec{v}) = -m^2 c^2 \left(1 + i \frac{(2\hat{k} \cdot \vec{v})}{c(1 - \frac{v^2}{c^2})}\right) \left(1 - \frac{v^2}{c^2}\right) \quad (40b)$$

with invariant magnitude  $\bar{P}$  obtained as

$$\bar{P}^2 = | -P^2 | = m^2 c^2 \sqrt{1 + \frac{4(\hat{k} \cdot \vec{v})^2}{c^2(1 - \frac{v^2}{c^2})^2}} \left(1 - \frac{v^2}{c^2}\right) = m^2 c^2 \eta \gamma^{-2} \quad (40c)$$

where  $\eta, \gamma$  are defined in equations (38e) and (39d).

The linear momentum four-vector  $P_0$  in the rest frame is defined by

$$P_0 = -im_0 c \hat{k} \quad (40d)$$

where  $m_0$  is the rest mass. The invariant magnitude  $\bar{P}_0$  of linear momentum in the rest frame is easily obtained as

$$\bar{P}_0^2 = | -P_0^2 | = m_0^2 c^2 \quad (40e)$$

Applying the invariance principle according to

$$\bar{P}^2 = \bar{P}_0^2 \quad (40f)$$

and using equations (40c) and (40e), we obtain the mass increase relation in the complex spacetime frame in the final form

$$m = \eta^{-\frac{1}{2}} \gamma m_0 \quad (40g)$$

which modifies the usual result obtained in Einstein's special theory of relativity by a temporal-spatial orientation factor  $\eta^{-\frac{1}{2}}$ .

### g) Energy conservation: dispersion relation

Let us now redefine the linear momentum four-vector  $P$  as an energy-momentum four-vector using the usual mass-energy equivalence relation  $E = mc^2$  to obtain

$$P = i \frac{E}{c} \hat{k} + \vec{p} \quad (41a)$$

giving

$$P^2 = p^2 - \frac{E^2}{c^2} - i(2 \frac{E}{c} \hat{k} \cdot \vec{p}) \quad (41b)$$

The invariant magnitude is then obtained as

$$\bar{P}^2 = |-P^2| = \sqrt{1 + \frac{(2 \frac{E}{c} \hat{k} \cdot \vec{p})^2}{(\frac{E^2}{c^2} - p^2)^2}} (\frac{E^2}{c^2} - p^2) = \eta (\frac{E^2}{c^2} - p^2) \quad (41c)$$

where  $\eta$  defined earlier in equation (38e) now takes the equivalent form

$$\eta = \sqrt{1 + \frac{(2 \frac{E}{c} \hat{k} \cdot \vec{p})^2}{(\frac{E^2}{c^2} - p^2)^2}} = \sqrt{1 + \frac{4c^2 (\hat{k} \cdot \vec{p})^2}{E^2 (1 - \frac{p^2 c^2}{E^2})^2}} \quad (41d)$$

We now apply the invariance principle according to equation (40f) and use the results from equations (40e) and (41c) to obtain

$$\sqrt{1 + \frac{4c^2 (\hat{k} \cdot \vec{p})^2}{E^2 (1 - \frac{p^2 c^2}{E^2})^2}} (\frac{E^2}{c^2} - p^2) = m_0^2 c^2 \quad (41e)$$

from which the general energy conservation law governing dynamics within the complex spacetime frame in the final form

$$E^2 = p^2 c^2 + \frac{m_0^2 c^4}{\sqrt{1 + \frac{4c^2 (\hat{k} \cdot \vec{p})^2}{E^2 (1 - \frac{p^2 c^2}{E^2})^2}}} = p^2 c^2 + \frac{m_0^2 c^4}{\eta} \quad (41f)$$

According to equation (41f), the general energy conservation law is modified by the general orientation of the temporal unit vector  $\hat{k}$  relative to the spatial unit vectors  $\hat{x}, \hat{y}, \hat{z}$  (which determine  $\hat{k} \cdot \vec{p}$  in this case). In the special case where the temporal axis is perpendicular to all the three spatial axes, the energy conservation law in equation (41f) takes the familiar form

$$\hat{k} \cdot \vec{p} = 0 \Rightarrow E^2 = p^2 c^2 + m_0^2 c^4 \quad (41g)$$

which is the standard result normally obtained in Einstein's special theory of relativity.

The general form of the energy conservation law (dispersion relation) obtained in equation (41f) takes the form proposed in theoretical models investigating possible violations of Lorentz invariance [5-8]. This means that unexpected dynamical effects currently associated with space anisotropy investigated in [3-4] and possible Lorentz invariance violations investigated in [5-8] may well be addressed by taking the temporal axis to be imaginary and arbitrarily

oriented to the spatial axes in the manner explained in the present paper. The results we have obtained here for the invariant length  $ds$  in equations (34d)-(34e) and the energy conservation law (dispersion relation) in equation (41f) take exactly the same forms derived or suggested in [3-4] and [5-8], respectively.

It may be understood that the observed discrepancies between theory and

experiment in relativistic particle physics, gravitation, cosmology and quantum field theory is due to an *incomplete specification* of the dynamical spacetime frame, which has been addressed in the present paper through derivation and identification of the temporal unit vector to define the imaginary temporal axis. The resulting complex spacetime frame with an imaginary temporal axis then provides the natural geometrical framework for describing the dynamics of physical systems. This takes us back to the original theories of Poincare and Lorentz on spacetime frames with imaginary temporal coordinates, which they abandoned in favor of the simpler non-Euclidean mathematical operations with four-vectors in real (Minkowski) spacetime frames [1-2].

### Contravariant and covariant complex four-vectors

To complete the mathematical formalism within complex four-dimensional spacetime frame, we introduce contravariant and covariant forms, which are useful in carrying out general mathematical operations with four-vectors. A contravariant four-vector is specified by positive spatial components, while a covariant four-vector is specified by negative spatial components. We represent the four-vector  $V$  in a contravariant form by  $V^\mu$  and in a covariant form by  $V_\mu$ , where  $\mu=0,1,2,3$  with 0 labeling the temporal component, while 1, 2, 3 label the spatial  $(x, y, z)$  components, respectively. We define  $V^\mu$  and  $V_\mu$  below.

Denoting the four unit vectors by  $\hat{k}, \hat{x}, \hat{y}, \hat{z}$  as presented in this paper, we define the contravariant coordinates  $x^\mu$  of the general

$$x^\mu, \mu=0,1,2,3 : x^0 = ict, x^1 = x, x^2 = y, x^3 = z \quad (42a)$$

The corresponding covariant coordinates  $x_\mu$  are defined in the form

$$x_\mu, \mu=0,1,2,3 : x_0 = x^0 = ict, x_1 = -x^1 = -x, x_2 = -x^2 = -y, x_3 = -x^3 = -z \quad (42b)$$

We then express the contravariant spacetime displacement four-vector  $X^\mu$  and the corresponding covariant form  $X_\mu$  as

$$X^\mu = -x^0 \hat{k} + x^1 \hat{x} + x^2 \hat{y} + x^3 \hat{z} ; X_\mu = -x_0 \hat{k} + x_1 \hat{x} + x_2 \hat{y} + x_3 \hat{z} \quad (42c)$$

which we introduce the position vector  $\vec{r} = x\hat{x} + y\hat{y} + z\hat{z}$  according to equations (42a)-(42b) to express in the final forms

$$X^\mu = -(ict\hat{k} - \vec{r}) ; X_\mu = -(ict\hat{k} + \vec{r}) \quad (42d)$$

The spacetime event interval takes the contravariant and covariant forms ( $dx^0 = dx_0$ )

$$dX^\mu = -dx_0 \hat{k} + d\vec{r} = -(icdt\hat{k} - d\vec{r}) ; dX_\mu = -dx_0 \hat{k} - d\vec{r} = -(icdt\hat{k} + d\vec{r}) \quad (42e)$$

A general four-vector  $\vec{V}$  as defined earlier is expressed in contravariant and covariant forms according to

$$V^0 = ic\Lambda, V^1 = V_x, V^2 = V_y, V^3 = V_z \quad (43a)$$

$$V_0 = V^0, V_1 = -V^1, V_2 = -V^2, V_3 = -V^3 \quad (43b)$$

with

$$V^\mu = -V^0 \hat{k} + V^1 \hat{x} + V^2 \hat{y} + V^3 \hat{z} ; V_\mu = -V_0 \hat{k} + V_1 \hat{x} + V_2 \hat{y} + V_3 \hat{z} \quad (43c)$$

which we express in the final forms

$$V^\mu = -(ic\Lambda \hat{k} - \vec{V}) ; V_\mu = -(ic\Lambda \hat{k} + \vec{V}) \quad (43d)$$

The contravariant and covariant four-vectors are related through complex conjugation in the form

$$V^{\mu*} = -V_\mu ; V_\mu^* = -V^\mu \quad (43e)$$

We use this contravariant-covariant four-vector conjugation relation to obtain

four-dimensional complex spacetime frame in the form

$$V^\mu \cdot V_\mu^* = -(V^\mu)^2 ; V^{\mu*} \cdot V_\mu = -(V_\mu)^2 \quad (43f)$$

which provides the definition of the invariant length  $\bar{V}$  of the general four-vector  $V^\mu$  or  $V_\mu$  according to

$$\bar{V}^2 = |-(V^\mu)^2| = |-(V_\mu)^2| \quad (43g)$$

We express this in the general form

$$\bar{V}^2 = |V^\mu \cdot V_\mu^*| = |V^{\mu*} \cdot V_\mu| \quad (43h)$$

Using  $V^\mu, V_\mu$  from equation (43d), noting the relation in equation (43e), we apply equation (43g) or (43h) to obtain the invariant length in the explicit form

$$\bar{V}^2 = \sqrt{1 + \frac{(2c\Lambda\hat{k} \cdot \vec{V})^2}{(c^2\Lambda^2 - |\vec{V}|^2)^2}} (c^2\Lambda^2 - |\vec{V}|^2) \quad (43i)$$

which is modified by a factor arising from the general orientation of the temporal unit vector relative to the spatial unit vectors.

### ***Tensors in the complex spacetime frame***

We now develop the procedure for defining tensors within the general four-dimensional complex spacetime frame. To put the presentation in familiar form, we adopt the standard contravariant and covariant four-vector notation to express  $V^\mu$  and  $V_\mu$  from equation (43d) in the form

$$V^\mu = -(ic\Lambda, -\vec{V}) ; V_\mu = -(ic\Lambda, \vec{V}) \quad (44a)$$

with complex conjugates taking the form

$$V^{\mu*} = (ic\Lambda, \vec{V}) = -V_\mu ; V_\mu^* = (ic\Lambda, -\vec{V}) = -V^\mu \quad (44b)$$

where the usual four-vector mathematics is applied, but now taking account of the general orientation of the temporal unit vector  $\hat{k}$  relative to the spatial unit vectors  $\hat{x}, \hat{y}, \hat{z}$  to obtain the general results presented above.

Using the complex conjugation relation from equation (21b) gives

$$V^\mu \cdot V_\nu^* = -V^\mu \cdot V^\nu ; V^{\mu*} \cdot V_\nu = -V_\mu \cdot V_\nu \quad (45a)$$

from which a definition of complex contravariant and covariant rank-2 tensors  $T^{\mu\nu}$  and  $T_{\mu\nu}$  follows according to

$$T^{\mu\nu} = -V^\mu \cdot V_\nu^* = V^\mu \cdot V^\nu ; TT_{\mu\nu} = -V^{\mu*} \cdot V_\nu = V_\mu \cdot V_\nu \quad (44b)$$

In addition,

$$V^\mu \cdot V^{\nu*} = -V^\mu \cdot V_\nu ; V^{\mu*} \cdot V^\nu = -V_\mu \cdot V^\nu \quad (45c)$$

provides a definition of complex rank-2 mixed tensors  $T_\nu^\mu$  and  $T_\mu^\nu$  in the form

$$T_\nu^\mu = -V^\mu \cdot V^{\nu*} = V^\mu \cdot V_\nu ; T_\mu^\nu = -V^{\mu*} \cdot V^\nu = V_\mu \cdot V^\nu \quad (45d)$$

The definition of more general tensors of higher rank follows easily. Some mathematical properties of the rank-2 tensors defined above can be obtained by interchanging the indices  $\mu, \nu$  or taking complex conjugation or carrying out both operations simultaneously.

The complete definition of contravariant and covariant complex four-vectors, which can be used to define tensors of general ranks in contravariant, covariant or mixed forms, provides the necessary foundation for more general vector and tensor analysis,

leading to reformulation of differential geometry a complex four-dimensional spacetime frame. This is indeed the origin of a new framework for studying physics, mathematics and related disciplines in the 21<sup>st</sup>-century and beyond.

### Conclusion

In this paper, we have successfully derived and specified a unit vector in the temporal direction to define a general complex four-dimensional spacetime frame with an imaginary temporal axis. The basic elements of the complex spacetime frame are complex four-vectors with components defined along the temporal and spatial axes specified by the corresponding unit vectors. The mathematical operations with these four-vectors follows the well developed procedures in standard vector analysis using three-component vectors defined within three-dimensional Euclidean space. We have obtained basic four-vector identities within the complex spacetime frame which take exactly the same forms and therefore generalize the corresponding vector identities established within the three-dimensional Euclidean space.

Dynamics of matter within the complex spacetime frame is determined by a general complex four-vector  $V$  propagating as a wave generated by matter sources. The curl of the complex four-vector  $(\nabla \times V)$  generates a unified field intensity  $F = \vec{R} + i\vec{Q} \times \hat{k}$  with a real part  $\vec{R}$  identified as the deflection (magnetic) component and imaginary part  $\vec{Q} \times \hat{k}$  identified as the translation (electric) component. The scalar form  $F^2$  provides an appropriately defined complex field Lagrangian density with an imaginary part taking the Poynting energy form, while  $F^* \cdot F = |F|^2$  provides a real total field energy density. We observe that a real Lagrangian density is obtained as  $|-F^2|$ . The space-time evolution of the unified field intensity components  $\vec{R}$  and  $\vec{Q}$  is governed by coupled Maxwell-type equations driven by matter density four-vector satisfying a

continuity equation. As usual, decoupling the Maxwell-type equations yields appropriate wave equations for  $\vec{R}$  and  $\vec{Q}$ . In general, the arbitrary orientation of the temporal axis relative to the three spatial axes yields a factor or term which modifies the field Lagrangian and total energy densities and the fundamental relativistic properties such as the invariant length of the event interval (the metric), time dilation, mass increase and energy conservation law (dispersion relation), among many other dynamical properties. Such temporal-spatial axes orientation dependent modifications of the fundamental results may account for possible discrepancies between experiment and theoretical predictions of phenomena based on the energy conservation principle, Lorentz invariance, etc, which constitute the major challenges to be overcome in current models of relativistic mechanics, quantum field theory and general relativity as a theory of gravitation and cosmology.

The contravariant and covariant forms of the complex four-vectors, which are related through complex conjugation, provide general definitions of tensors within the complex spacetime frames. The new and more general mathematical operations with complex four-vectors and tensors provide the framework and necessary motivation for reformulating differential geometry, relativistic mechanics, quantum field theory, general relativity and cosmological models, which are directly based on mathematical properties defined within four-dimensional spacetime frames.

### Acknowledgement

I thank Maseno University, Kenya, for supporting this work by providing facilities and working environment.

### References

- Amelio-Camelia G.** (2002), *Relativity in spacetimes with short-distance structure governed by an observer-independent*



- (Planckian) length scale, *Int. J. Mod. Phys. D* **11**, 35 (2002); arXiv: 0012051 [gr-qc].
- Bogoslovsky, G. Y.** (2007). *Some physical displays of the space anisotropy relevant to the feasibility of its being detected at a laboratory*, arXiv: 0706.2621 [gr-qc].
- Costa, L. F. and Herdeiro, C. A. R.** (2008). *A gravito-electromagnetic analogy based on tidal tensors*, *Phys. Rev. D* **78**, 024021 (2008); DOI:10.1103/PhysRevD.78.024021 ; arXiv: 0612140 [gr-qc].
- Gibbons G. W., Gomis, J. and Pope, C. N.** (2007). *General Very Special Relativity in Finsler Geometry*, *Phys. Rev.D* **76**, 081701 (2007) ; DOI:10.1103/PhysRevD.76.081701; arXiv: 0707.2174 [hep-th].
- Hendrik A. L.** (1904). *Electromagnetic phenomena in a system moving with any velocity smaller than that of light*, *Proceedings of the Royal Netherlands Academy of Arts and Sciences* **6**, 809.
- Henri, P.** (1906). *Sur la dynamique de l'électron (On the dynamics of the electron)*, *Rendiconti del Circolo Matematico di Palermo* **21**, 129; DOI:10.1007/BF03013466.
- Huiquan L.** (2010). *Gravito-electromagnetism and decomposition of gravity*, arXiv: 0612140 [hep-th].
- Magueijo, J. and Smolin, L.** (2002) *Lorentz invariance with an invariant energy scale*, *Phys. Rev. Lett.* **88**, 190403 (2002); arXiv: 0112090 [hep-th].
- Magueijo, J. and Smolin, L.** (2003). *Generalized Lorentz invariance with an invariant energy scale*, *Phys. Rev. D* **67**, 044017 (2003); arXiv: 0207085 [gr-qc].
- Mashhoon, B.** (2003). *Gravitoelectromagnetism*, arXiv: 0311030 [gr-qc].
- Mattingly, D.** (2002). *Modern Tests of Lorentz Invariance*, *Living Rev. Rel.* **8**, 5 (2005); arXiv: 0502097 [gr-qc].
- Ruggiero, M.L. and Tartaglia, A.T.** (2002). *Gravitomagnetic effects*, *Nuovo Cim.* **117B**, 743 (2002); arXiv: 0612140 [gr-qc].

### **Submission of Papers**

Manuscripts for Maseno University Journal should be submitted by e-mail to [couma@maseno.ac.ke](mailto:couma@maseno.ac.ke) . **This is the preferred method of submission**, but only in exceptional cases where the authors have no electronic facilities, the author should submit one original copy of the manuscript, two photocopies and an electronic copy on disk, to the Editor-in-Chief.

On a separate page, give full name(s) of authors and institutional affiliation(s) of author(s), including address for correspondence, (approximately 50 words). Please also provide an abstract, summarizing the thesis of the article in not more than 150 words.

The main title should clearly reflect the content of the article and should be no longer than 20 words. Provide headings and subheadings to signify the structure of your article. Main headings should be in bold type and subheadings italicised; use lower case letters.

It is the author's responsibility to ensure that manuscripts are written in clear and comprehensible English. Authors whose mother tongue is not English language are strongly advised to have their manuscripts checked by an English-speaking colleague prior to submission.

Submission of a manuscript implies that it has not been published previously (except in the form of an abstract or as part of a published lecture or academic thesis); that it is not under consideration for publication elsewhere; that its publication is approved by all authors and tacitly or explicitly by the responsible authorities where the work was carried out, and that, if accepted, it will not be published elsewhere in the same form, in English or in any other language, without the written consent of the Publisher.

Limit the number of notes to those that are essential, and keep them as brief as possible. Collect them at the end of the text, not at the foot of the page. Do not use the automatic Footnote/Endnote facility if you word-process your text.

Responsibility for opinion expressed and for accuracy of facts published in articles and reviews rests solely with individual author(s).

Receipt of manuscript will be acknowledged within 2 weeks.

#### *Types of Contributions*

Contributions shall be original research papers; review papers; rapid communications; short communications; viewpoints; letters to the Editor; book reviews.

1. *Research papers* - original full-length research papers that have not been published previously, except in a preliminary form, and should not exceed 10,000 words (including allowance for no more than 6 tables and illustrations).
2. *Review papers* - will be accepted in areas of topical interest, will normally focus on literature published over the previous five years, and should not exceed 10,000 words (including allowance for no more than 6 tables and illustrations).
3. *Short communications* - Short communications of up to 1,200 words, describing work that may be of a preliminary nature, but which merits immediate publication. Authors may also submit viewpoints of about 1200 words on any subject covered by the aims and scope.

4. *Letters to the Editor* - Letters are published from time to time on matters of topical interest.

5. *Book reviews*

## Manuscript Preparation

**General:** Manuscripts must be 1.5-spaced, Time Roman font size 12 with 3cm margins on both sides of A4 page.

**Abstracts:** Each paper should have an abstract of 100-150 words, reporting concisely on the purpose and results of the paper.

**Text:** Follow this order when typing manuscripts: Title page (Authors, Affiliations, Vitae, Abstract, Keywords), Main text, Acknowledgements, References, Figure Captions, Tables and then Appendix. Do not import the Figures or Tables into your text. The corresponding author should be identified with an asterisk and footnote. All other footnotes (except for table footnotes) should be identified with superscript Arabic numbers. The title of the paper should unambiguously reflect its contents. Where the title exceeds 70 characters a suggestion for an abbreviated running title should be given.

**Units:** The SI system should be used for all scientific and laboratory data; if, in certain instances, it is necessary to quote other units, these should be added in parentheses. Temperatures should be given in degrees Celsius. The unit 'billion' ( $10^9$  in America,  $10^{12}$  in Europe) is ambiguous and should not be used. Use metric measurements (or state the equivalent). Similarly, give a US dollar equivalent of other currencies.

**Symbols:** Abbreviations for units should follow the suggestions of the British Standards publication BS 1991. The full stop should not be included in abbreviations, e.g. m (not m.), ppm (not p.p.m.), % and '/' should be used in preference to 'per cent' and 'per'. Where abbreviations are likely to cause ambiguity or may not be readily understood by an international readership, units should be put in full.

Current recognised (IUPAC) chemical nomenclature should be used, although commonly accepted trivial names may be used where there is no risk of ambiguity.

The use of proprietary names should be avoided. Papers essentially of an advertising nature will not be accepted.

**References:** All publications cited in the text should be presented in a list of references following the text of the manuscript. No more than 30 references should be cited in your manuscript. In the text refer to the author's name (without initials) and year of publication (e.g. "Oketch-Rabah, Mwangi, Listergen and Mberu (2000) studied the effects..." or "...similar to values reported by others (Getenga, Jondiko & Wandiga, 2000)..."). For 2-6 authors all, authors are to be listed at first citation. At subsequent citations use first author *et al.* When there are more than 6 authors, first author *et al.* should be used throughout the text. The list of references should be arranged alphabetically by authors' surnames and should be as full as possible, listing all authors, the full title of articles and journals, publisher and year. The manuscript should be carefully checked to ensure that the spelling of authors' names and dates are exactly the same in the text as in the reference list.

References should be given in the following form:

Ahmed, I. A., & Robinson, R. K. (1999). The ability of date extracts to support the production of aflatoxins. *Food Chemistry*, 66(3), 307-312.

Marasas, W. F. O. (1996). Fumonisin: History, worldwide occurrence and impact. In L. S. Jackson, J. W. DeVries, & L. B. Bullerman, eds. *Fumonisin in food, advances in experimental medicine and biology*, vol. 392 (pp. 1-18). New York: Plenum Press.

Massart, D. L., & Kauffmann, L. (1983). *Interpretation of analytical data by use of cluster analysis*. New York: Wiley.

Noel, S., & Collin, S. (1995). Trans-2-nonenal degradation products during mashing. In *Proceedings of the 25th European brewery convention congress* (pp. 483-490). Oxford: IRL Press.

*Citing and listing of web references:* As a minimum, the full URL should be given. Any further information, if known (author names, dates, reference to a source publication, etc.), should also be given. Web references can be listed separately (e.g., after the reference list) under a different heading if desired, or can be included in the reference list.

## **Illustrations**

Photographs, charts and diagrams are all to be referred to as "Figure(s)" and should be numbered consecutively in the order to which they are referred. They should accompany the manuscript, but should not be included within the text. All illustrations should be clearly marked with the figure number and the author's name. All figures are to have a caption. Captions should be supplied on a separate sheet. Tables should be numbered consecutively and given a suitable caption and each table typed on a separate sheet. Footnotes to tables should be typed below the table and should be referred to by superscript lowercase letters. No vertical rules should be used.

## **Preparation of electronic illustrations**

Submitting your artwork in an electronic format helps us to produce your work to the best possible standards, ensuring accuracy, clarity and a high level of detail. Authors must ensure that submitted artwork is camera ready.

### *Proofs*

When your manuscript is received at the Publisher it is considered to be in its final form. Proofs are not to be regarded as 'drafts'. One set of page proofs in PDF format will be sent by e-mail to the corresponding author, to be checked for typesetting/editing. No changes in, or additions to, the accepted (and subsequently edited) manuscript will be allowed at this stage. Proofreading is solely the author(s) responsibility. A form with queries from the copy editor may accompany your proofs. Please answer all queries and make any corrections or additions required. The Publisher reserves the right to proceed with publication if corrections are not communicated. Return corrections within 14 working days of receipt of the proofs. Should there be no corrections, please confirm this. Maseno University Journal will do everything possible to get your article corrected and published as quickly and accurately as possible. In order to do this we need your help. When you receive the (PDF) proof of your article for correction, it is important to ensure that all of your corrections are sent back to us in one communication. Subsequent corrections will not be possible, so please ensure your first sending is complete. Note that this does not mean you have any less time to make your corrections, just that only one set of corrections will be accepted.

### *Offprints*

The editors reserve the right to copyedit and proof all articles accepted for publication. Acceptance of the article will imply assignment of copyright by its author(s) to Maseno University Journal. Authors receive a complimentary copy of the issue. Authors of book reviews receive 4 off-prints.

### *Copyright*

Upon acceptance of an article, authors will be asked to transfer copyright. This transfer will ensure the widest possible dissemination of information. A letter will be sent to the corresponding author confirming receipt of the manuscript. A form facilitating transfer of copyright will be provided. If excerpts from other copyrighted works are included, the

author(s) must obtain written permission from the copyright owners and credit the source(s) in the article.

**Contact:**  
Editor in Chief  
Maseno University Journal  
Maseno University,  
P.O. Box 333-40105 Maseno, Kenya.  
Email: [coums@maseno.ac.ke](mailto:coums@maseno.ac.ke).